

CLEARANCE FOR BUNDLE REMOVAL FROM SHELL FLANGE

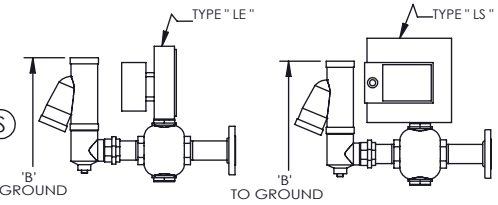

- NOTES:
- REFER TO PRODUCT SPECIFICATION FOR DESCRIPTION OF LETTERED ITEMS.
 - CONDENSATE: CONDENSATE IS TO BE PIPED FROM HEATER WITHOUT LIFTS TO A VENTED RECEIVER OR DRAIN BELOW THE ELEVATION OF THE HEATER'S CONDENSATE OUTLET.
 - INSTALLATION: ALL COMPONENTS SHOWN HERE ARE PREWIRED & PREPARED BY ACE HEATERS. CUSTOMER WILL ONLY NEED TO PLUMB WATER TO BE HEATED, PIPE STEAM AND CONDENSATE LINES, AND BRING ELECTRICITY TO UNIT.
 - DIMENSIONS ARE SUBJECT TO CHANGE. CONSULT FACTORY FOR TIGHT DIMENSIONS.
 - THIS CONFIGURATION CHANGES FOR VALVE SIZE 1/2" TO 2". SEE DETAIL 1 FOR REFERENCE.
- APPROX. EMPTY WT:

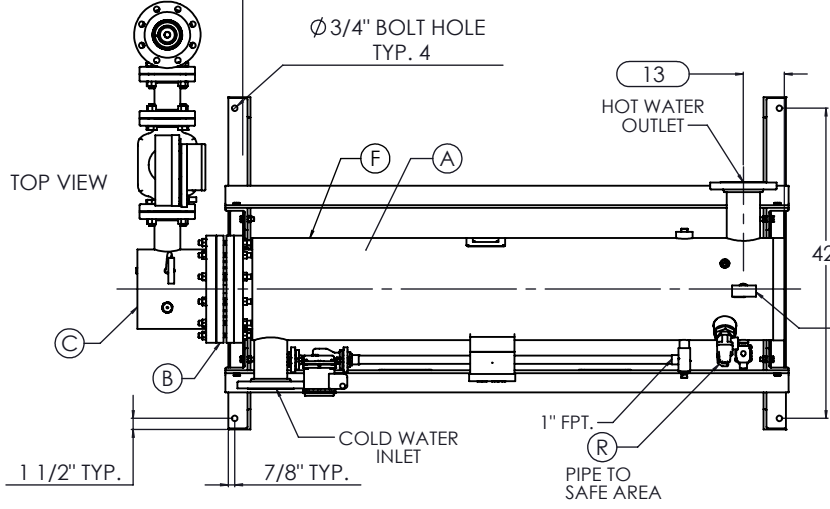
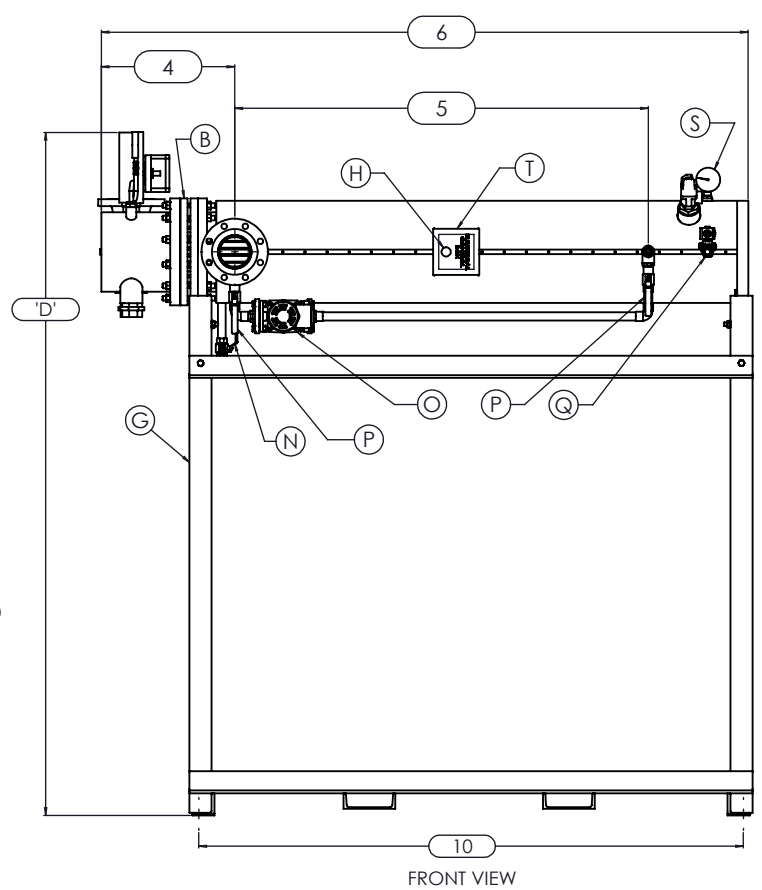
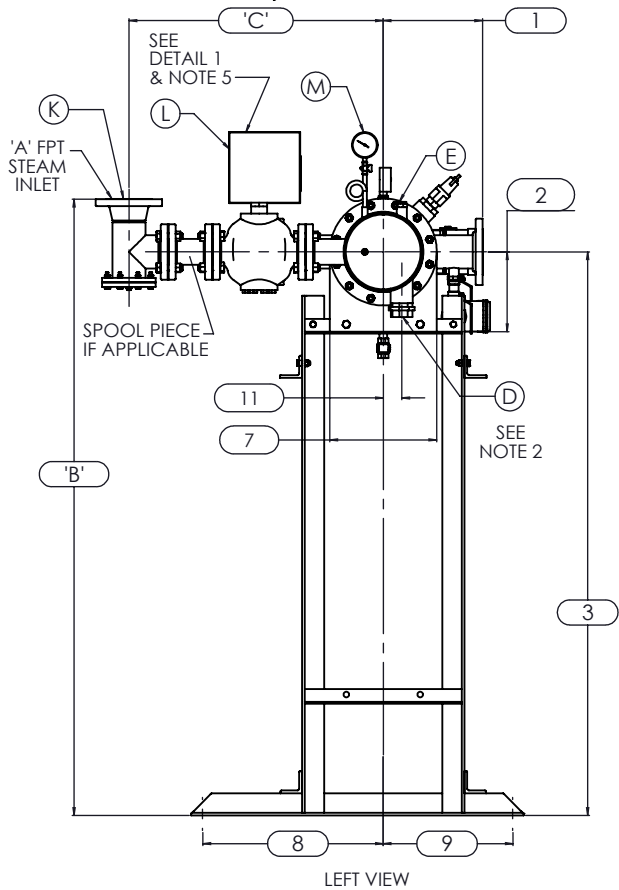

	CERTIFIED BY Ace Heaters, LLC www.aceheaters.com	
	MAXIMUM ALLOWABLE WORKING PRESSURE SHELL <u>150</u> PSI @ <u>210</u> °F TUBES <u>150</u> PSI @ <u>370</u> °F MIN. D.M.T. <u>0</u> °F @ <u>150</u> PSI S/N _____ YEAR BUILT _____	
	MODEL _____ CAPACITY _____ GAL SA. _____ JOB NO. _____ XXX	

Ace Heaters, LLC www.aceheaters.com		
This document contains proprietary information from AHS, LLC. Do not reproduce or distribute without prior written consent of AHS, LLC.	ASME Section VIII Div 1: 2015 Ed. Design Pressure: 150 psig Test Pressure: 195 psig Max Design Temperature: 370°F	A.I.:
SCALE: NA Dwg By: JL	Filename: SIHDW - COVER Orig Date: 12/30/2015 Rev Date:	SHEET 1 OF 2 Checked By:
MINIPACK SYSTEM - HORIZONTAL - DW STEAM - WARREN ELECT. VALVE PACKAGE - SINGLE UNIT ON DUAL RACK		
Dwg #: SIHDWSE-1-DR-WARREN		SO: _____ REV 01

SIHDWSE-1-DR, DW - STEAM - WARREN ELECTRIC VALVE PACKAGE - SINGLE UNIT ON RACK								
	MP SIZE	5	6	8	10	12	14	16
ITEMS	1	10	10 1/2	11 1/2	13 1/2	14 1/2	15 1/2	16 1/2
	2	7 11/16	8 3/16	10 1/8	10 13/16	12 1/2	12 1/4	14
	3	59 15/16	60 7/16	62 3/8	76 1/16	77 3/4	77 1/2	79 1/4
	4	13 7/8	14 3/8	15 7/8	17 5/8	23 9/16	24 13/16	28 9/16
	5	55	54 1/2	55 1/4	56	54 1/2	63	66 3/4
	6	80 3/16	81 5/16	83 9/16	87 1/8	94 7/16	104 1/16	110 15/16
	7	8 3/4	9 7/8	11 7/8	14 1/2	16 5/8	18 1/2	20
	8	26 1/2	26 1/2	26 1/2	26 1/2	26 1/2	26 1/2	26 1/2
	9	15 1/2	15 1/2	15 1/2	15 1/2	15 1/2	15 1/2	15 1/2
	10	68 1/4	69 3/8	70 3/8	71 7/8	74 5/16	82 15/16	82 15/16
	11	1 3/8	1 1/2	2 1/16	2 1/2	3 1/16	3 1/8	3 1/4
	12	64	64	64	64	64	75	80
	13	4 13/16	4 13/16	5 15/16	5 11/16	8 1/8	7 1/4	7 3/8
INLET PIPE SIZE		2 1/2 FLG.	2 1/2 FLG.	3 FLG.	4 FLG.	4 FLG.	5 FLG.	6 FLG.
OUTLET PIPE SIZE		2 1/2 FLG.	2 1/2 FLG.	3 FLG.	4 FLG.	4 FLG.	5 FLG.	6 FLG.
VALVE SIZE	ITEM	VALVE SIZE AND OVERALL LOCATION						
1/2"	'A'	3/4						
	'B'	70 7/16	70 15/16	72 7/8	86 9/16	88 1/4	88	89 3/4
	'C'	20 7/16	20 11/16	21 11/16	24 3/16	25 11/16	27 11/16	29 11/16
	'D'	73 3/4	74 1/4	76 3/16	89 7/8	91 9/16	91 5/16	93 1/16
3/4"	'A'	1						
	'B'	70 1/2	71	72 15/16	86 5/8	88 5/16	88 1/16	89 13/16
	'C'	20 7/16	20 11/16	21 11/16	24 3/16	25 11/16	27 11/16	29 11/16
	'D'	73 3/4	74 1/4	76 3/16	89 7/8	91 9/16	91 5/16	93 1/16
1"	'A'	1 1/4						
	'B'	69 13/16	70 5/16	72 1/4	85 15/16	87 5/8	87 3/8	89 1/8
	'C'	22 1/4	22 1/2	23 1/2	26	27 1/2	29 1/2	31 1/2
	'D'	73 3/4	74 1/4	76 3/16	89 7/8	91 9/16	91 5/16	93 1/16
1 1/4"	'A'	1 1/2						
	'B'	70 7/8	71 3/8	73 5/16	87	88 11/16	88 7/16	90 3/16
	'C'	23 1/16	23 5/16	24 5/16	26 13/16	28 5/16	30 5/16	32 5/16
	'D'	74 3/8	74 7/8	76 13/16	90 1/2	92 3/16	91 15/16	93 11/16
1 1/2"	'A'	2						
	'B'	70 7/8	71 3/8	73 5/16	87	88 11/16	88 7/16	90 3/16
	'C'	24 7/8	25 1/8	26 1/8	28 5/8	30 1/8	32 1/8	34 1/8
	'D'	74 3/8	74 7/8	76 13/16	90 1/2	92 3/16	91 15/16	93 11/16
2"	'A'	2 1/2						
	'B'	71 5/16	71 13/16	73 3/4	87 7/16	89 1/8	88 7/8	90 5/8
	'C'	26 13/16	27 1/16	28 1/16	30 9/16	32 1/16	34 1/16	36 1/16
	'D'	74 3/8	74 7/8	76 13/16	90 1/2	92 3/16	91 15/16	93 11/16
2 1/2"	'A'	3						
	'B'	64 9/16	65 1/16	67	80 11/16	82 3/8	82 1/8	83 7/8
	'C'	23 7/8	24 1/8	25 1/8	27 5/8	29 1/8	31 1/8	33 1/8
	'D'	76 3/16	76 11/16	78 5/8	92 5/16	94	93 3/4	95 1/2
3"	'A'	4						
	'B'	N/A	67 5/8	69 9/16	83 1/4	84 15/16	84 11/16	86 7/16
	'C'	N/A	24 15/16	25 15/16	28 7/16	29 15/16	31 15/16	33 15/16
	'D'	N/A	76 11/16	78 5/8	92 5/16	94	93 3/4	95 1/2
4"	'A'	6						
	'B'	N/A	N/A	71 9/16	85 1/4	86 15/16	86 11/16	88 7/16
	'C'	N/A	N/A	32 15/16	35 7/16	36 15/16	38 15/16	40 15/16
	'D'	N/A	N/A	77 5/8	91 5/16	93	92 3/4	94 1/2
5"	'A'	6						
	'B'	N/A	N/A	N/A	85 1/4	86 15/16	86 11/16	88 7/16
	'C'	N/A	N/A	N/A	35 7/16	36 15/16	38 15/16	40 15/16
	'D'	N/A	N/A	N/A	91 5/16	93	92 3/4	94 1/2

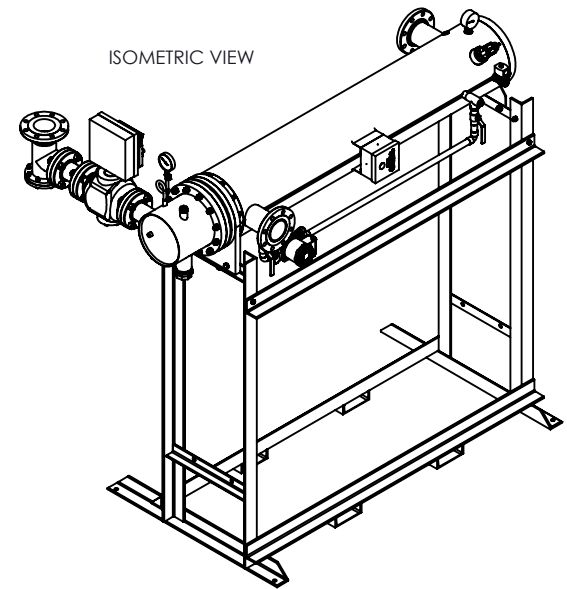

NOTES:

- 1/ DIMENSIONS IN INCHES, AND SUBJECT TO CHANGE WITHOUT NOTICE.
- 2/ DIM 'B', 'C', 'D' ARE TO BE APPROXIMATED ONLY, CONSULT FACTORY FOR TIGHT DIMENSIONS.

Ace Heaters, LLC www.aceheaters.com		
This document contains proprietary information from AHS, LLC. Do not reproduce or distribute without prior written consent of AHS, LLC.	ASME Section VIII Div 1: 2015 ED Design Pressure: 150 psig Test Pressure: 195 psig Max Design Temperature: 370°F	A.I.:
SCALE: NA	Filename: SIHDW - COVER	SHEET 2 OF 2
Dwg By: JL	Orig Date: 12/30/2015	Rev Date: _____ Checked By: _____
MINIPACK SYSTEM - HORIZONTAL - DW STEAM - WARREN ELECT. VALVE PACKAGE - SINGLE UNIT ON DUAL RACK		
Dwg #: SIHDWSE-1-DR-WARREN-DIM	SO: _____	REV 01