

NOTES:

1. REFER TO PRODUCT SPECIFICATION FOR DESCRIPTION OF LETTERED ITEMS.
2. INSTALLATION:  
ALL COMPONENTS SHOWN HERE ARE PREWIRED & PREPARED BY ACE HEATERS. CUSTOMER WILL ONLY NEED TO PLUMB WATER TO BE HEATED, PIPE STEAM AND CONDENSATE LINES, AND BRING ELECTRICITY TO UNIT.
3. DIMENSIONS ARE SUBJECT TO CHANGE. CONSULT FACTORY FOR TIGHT DIMENSIONS.
4. THIS CONFIGURATION CHANGES FOR VALVE SIZE 1/2" TO 2". SEE DETAIL 1 FOR REFERENCE.

APPROX. EMPTY WT:

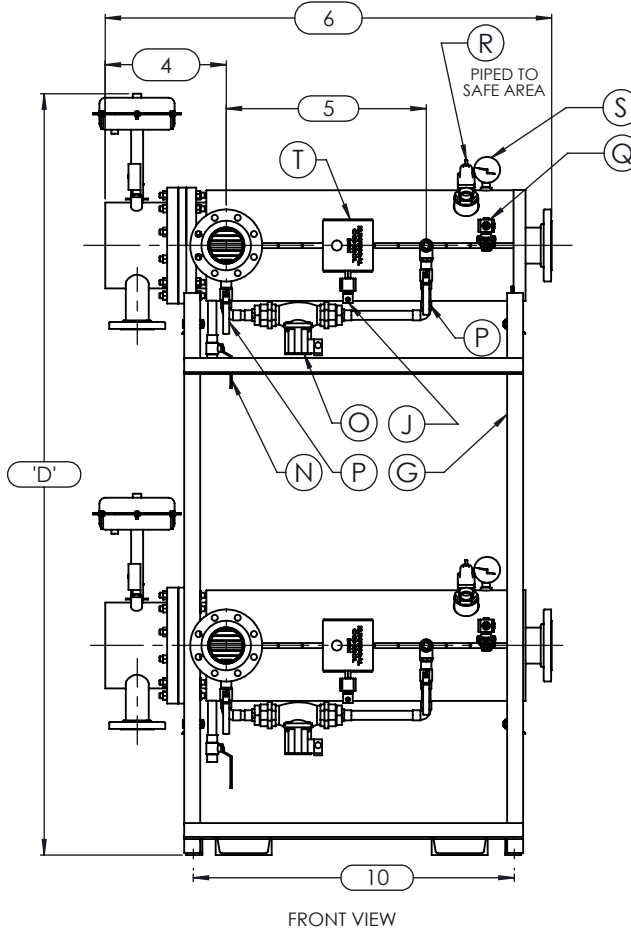
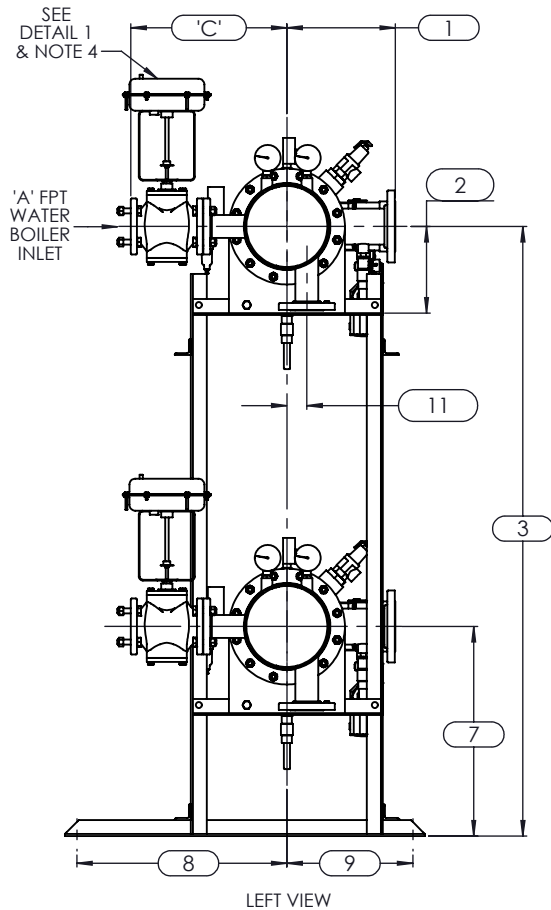

	CERTIFIED BY <b>Ace Heaters, LLC</b> www.aceheaters.com
	MAXIMUM ALLOWABLE WORKING PRESSURE SHELL 150 PSI @ 210 °F TUBES 150 PSI @ 370 °F
	MIN. D.M.T. 0 °F @ 150 PSI S/N _____ YEAR BUILT _____
	MODEL _____ CAPACITY _____ GAL SA. _____
	JOB NO. _____ XXX

**ACE HEATERS, LLC**

www.aceheaters.com

This document contains proprietary information from AHS, LLC. Do not reproduce or distribute without prior written consent of AHS, LLC.		ASME Section VIII Div 1: 2015 Ed. Design Pressure: 150 psig Test Pressure: 195 psig Max Design Temperature: 370°F	A.I:
SCALE: NA	Filename: SIHSW - COVER		
Dwg By: JL	Orig Date: 12/23/15	Rev Date:	Checked By:
<b>MINIPACK SYSTEM - HORIZONTAL - SW</b>			
WATER 2W - PNEUMATIC VALVE PACKAGE - DUAL UNIT ON DUAL RACK			
Dwg #: SIHSWSA-2-DR-2W [so:			REV 01

SIHSW A-2W-2DR - DIM. SW - WATER - PNEUMATIC 2-WAY MIXING VALVE PACKAGE SIZE AND LOCATION: DUAL UNIT ON RACK														
MP SIZE		4	5	6	8	8L	10	10L	12	12L	14	14L	16	16L
ITEMS	1	9 1/2	11 7/16	12	11 1/2	11 1/2	13 3/8	13 3/8	14 3/8	14 3/8	15 3/4	15 3/4	17 5/8	17 5/8
	2	6 5/16	7 11/16	8 3/16	10 1/8	10 1/8	10 13/16	10 13/16	12 1/2	12 1/2	12 1/4	12 1/4	14	14
	3	58 9/16	59 15/16	60 7/16	62 3/8	62 3/8	76 1/16	76 1/16	77 3/4	77 3/4	77 1/2	77 1/2	79 1/4	79 1/4
	4	12 7/8	12 7/8	13 3/8	14 7/8	14 7/8	16 3/8	15 11/16	22 5/16	22 5/16	23 7/16	23 11/16	26 15/16	26 15/16
	5	30	23	30 1/4	24 3/4	30 3/4	25	31 11/16	24 1/2	36 1/2	30 1/2	45 3/4	40 1/2	54 1/2
	6	56	49	57 3/8	53 7/8	59 7/8	55 1/2	61 1/2	57 15/16	69 15/16	69 7/8	85 1/8	83 5/8	97 5/8
	7	21 9/16	22 15/16	23 7/16	25 3/8	25 3/8	26 3/16	26 3/16	27 7/8	27 7/8	27 5/8	27 5/8	29 3/8	29 3/8
	8	26 1/2	26 1/2	26 1/2	26 1/2	26 1/2	26 1/2	26 1/2	26 1/2	26 1/2	26 1/2	26 1/2	26 1/2	26 1/2
	9	15 1/2	15 1/2	15 1/2	15 1/2	15 1/2	15 1/2	15 1/2	15 1/2	15 1/2	15 1/2	15 1/2	15 1/2	15 1/2
	10	42 3/4	35 3/4	44 1/8	39 1/8	44 7/8	39 3/4	45 3/4	42	54 1/4	49 3/4	65	62 1/4	76 1/4
	11	1	1 3/8	1 1/2	2 1/16	2 1/16	2 1/2	2 1/2	3 1/16	3 1/16	3 1/8	3 1/8	3 1/4	3 1/4
	12	37	31	38	33	39	34	40	35	47	42	57	53	67
INLET PIPE SIZE		2 THR.	2 1/2 FLG.	2 1/2 FLG.	3 FLG.	3 FLG.	4 FLG.	4 FLG.	4 FLG.	4 FLG.	5 FLG.	5 FLG.	6 FLG.	6 FLG.
OUTLET PIPE SIZE		2 THR.	2 1/2 FLG.	2 1/2 FLG.	3 FLG.	3 FLG.	4 FLG.	4 FLG.	4 FLG.	4 FLG.	5 FLG.	5 FLG.	6 FLG.	6 FLG.
VALVE SIZE 'A'	ITEM	VALVE SIZE AND OVERALL LOCATION												
1/2"	'C'	15 9/16	16 1/16	16 5/16	17 5/16	17 5/16	19 13/16	19 13/16	21 5/16	21 5/16	23 5/16	23 5/16	25 5/16	25 5/16
	'D'	74 3/8	75 3/4	76 1/4	78 3/16	78 3/16	91 7/8	91 7/8	93 9/16	93 9/16	93 5/16	93 5/16	95 1/16	95 1/16
3/4"	'C'	16 9/16	17 1/16	17 5/16	18 5/16	18 5/16	20 13/16	20 13/16	22 5/16	22 5/16	24 5/16	24 5/16	26 5/16	26 5/16
	'D'	74 3/8	75 3/4	76 1/4	78 3/16	78 3/16	91 7/8	91 7/8	93 9/16	93 9/16	93 5/16	93 5/16	95 1/16	95 1/16
1"	'C'	16 9/16	17 1/16	17 5/16	18 5/16	18 5/16	20 13/16	20 13/16	22 5/16	22 5/16	24 5/16	24 5/16	26 5/16	26 5/16
	'D'	74 3/8	75 3/4	76 1/4	78 3/16	78 3/16	91 7/8	91 7/8	93 9/16	93 9/16	93 5/16	93 5/16	95 1/16	95 1/16
1 1/4"	'C'	16 9/16	17 1/16	17 5/16	18 5/16	18 5/16	20 13/16	20 13/16	22 5/16	22 5/16	24 5/16	24 5/16	26 5/16	26 5/16
	'D'	74 3/8	75 3/4	76 1/4	78 3/16	78 3/16	91 7/8	91 7/8	93 9/16	93 9/16	93 5/16	93 5/16	95 1/16	95 1/16
1 1/2"	'C'	16 9/16	17 1/16	17 5/16	18 5/16	18 5/16	20 13/16	20 13/16	22 5/16	22 5/16	24 5/16	24 5/16	26 5/16	26 5/16
	'D'	75 1/8	76 1/2	77	78 15/16	78 15/16	92 5/8	92 5/8	94 5/16	94 5/16	94 1/16	94 1/16	95 13/16	95 13/16
2"	'C'	17 15/16	18 7/16	18 11/16	19 11/16	19 11/16	22 3/16	22 3/16	23 11/16	23 11/16	25 11/16	25 11/16	27 11/16	27 11/16
	'D'	76 13/16	78 3/16	78 11/16	80 5/8	80 5/8	94 5/16	94 5/16	96	96	95 3/4	95 3/4	97 1/2	97 1/2
2 1/2"	'C'		15 3/4	16	17	17	19 1/2	19 1/2	21	21	23	23	25	25
	'D'	N/A	78 15/16	79 7/16	81 3/8	81 3/8	95 1/16	95 1/16	96 3/4	96 3/4	96 1/2	96 1/2	98 1/4	98 1/4
3"	'C'			17	18	18	20 1/2	20 1/2	22	22	24	24	26	26
	'D'	N/A	N/A	81 5/16	83 1/4	83 1/4	96 15/16	96 15/16	98 5/8	98 5/8	98 3/8	98 3/8	100 1/8	100 1/8
4"	'C'			21	21	21	23 1/2	23 1/2	25	25	27	27	29	29
	'D'	N/A	N/A	N/A	85 1/4	85 1/4	98 15/16	98 15/16	100 5/8	100 5/8	100 3/8	100 3/8	102 1/8	102 1/8
5"	'C'						26 1/4	26 1/4	27 3/4	27 3/4	29 3/4	29 3/4	31 3/4	31 3/4
	'D'	N/A	N/A	N/A	N/A	N/A	98 15/16	98 15/16	100 5/8	100 5/8	100 3/8	100 3/8	102 1/8	102 1/8

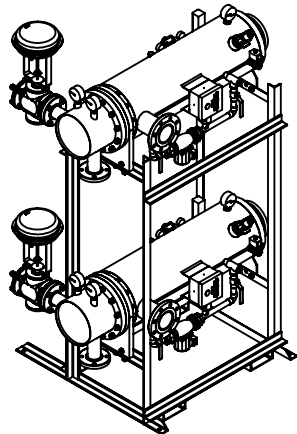

ISOMETRIC VIEW

NOTES:  
 1/ DIMENSIONS IN INCHES, AND SUBJECT TO CHANGE WITHOUT NOTICE.  
 2/ DIM 'C', 'D' ARE TO BE APPROXIMATED ONLY, CONSULT FACTORY FOR TIGHT DIMENSIONS.

ACE HEATERS, LLC		
This document contains proprietary information from AHS, LLC. Do not reproduce or distribute without prior written consent of AHS, LLC.	ASME Section VIII Div 1: 2015 Ed. Design Pressure: 150 psig Test Pressure: 195 psig Max Design Temperature: 370°F	A.I.:
SCALE: NA	Filename: SIHSW - COVER	SHEET 2 OF 2
Dwg By: JL	Orig Date: 12/23/15	Rev Date: _____ Checked By: _____
MINIPACK SYSTEM - HORIZONTAL - SW WATER 2W - PNEUMATIC VALVE PACKAGE - DUAL UNIT ON DUAL RACK		
Dwg #: SIHSWAA-2-DR-2W - DIM	SO:	REV 01