

NOTES:

1. REFER TO PRODUCT SPECIFICATION FOR DESCRIPTION OF LETTERED ITEMS.
2. INSTALLATION:  
ALL COMPONENTS SHOWN HERE ARE PREWIRED & PREPIPED BY ACE HEATERS. CUSTOMER WILL ONLY NEED TO PLUMB WATER TO BE HEATED, PLUMB BOILER WATER, HOOKUP AIR TO AIR FILTER-PRESSURE REGULATOR, AND BRING ELECTRICITY TO UNIT.
3. DIMENSIONS ARE SUBJECT TO CHANGE. CONSULT FACTORY FOR TIGHT DIMENSIONS.
4. THIS CONFIGURATION CHANGES FOR VALVE SIZE 1/2" TO 2". SEE DETAIL 2 FOR REFERENCE.
5. ADD 6" SPOILER TO CAP INLET IF APPL.

APPROX. EMPTY WT:

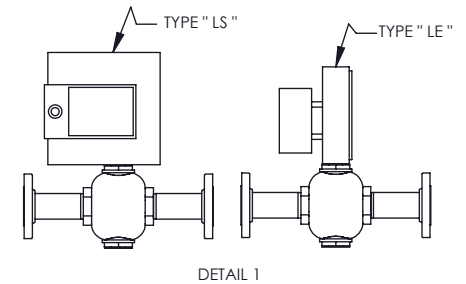

	CERTIFIED BY <i>Ace Heaters, LLC</i> www.aceheaters.com
	MAXIMUM ALLOWABLE WORKING PRESSURE SHELL 150 PSI @ 210 °F TUBES 150 PSI @ 370 °F
	MIN. D.M.T. 0 °F @ 150 PSI S/N _____ YEAR BUILT _____
	MODEL _____ CAPACITY _____ GAL SA. _____
	JOB NO. _____

<b>Ace Heaters, LLC</b> www.aceheaters.com		
This document contains proprietary information from AHS, LLC. Do not reproduce or distribute without prior written consent of AHS, LLC.	ASME Section VIII Div 1: 2015 Ed. Design Pressure: 150 psig Test Pressure: 195 psig Max Design Temperature: 370°F	A.I:
SCALE: NA	Filename: SIVDW - COVER	SHEET 1 OF 1
Dwg By: JL	Orig Date: 12/17/15	Rev Date: _____ Checked By: _____
<b>MINIPACK SYSTEM - VERICAL DW</b> Water 2W - Warren Electric Valve Package		
Dwg #: SIVDWWE-2W - WARREN	SO: _____	REV 1

SIVSWWE-2W-WARREN, WATER - WARREN ELECTRIC OPERATED VALVE PACKAGE SIZE AND LOCATION

MP SIZE	5	6	8	10	12	14	16
ITEMS	1	10	10 1/2	11 1/2	13 1/2	14 1/2	16 1/2
D	2	10 3/16	12 11/16	12 3/16	16 5/8	18 1/2	17 7/16
I	3	16 15/16	19 5/16	19 7/16	23 3/4	22 1/2	23 15/16
M	4	27 9/16	30 9/16	31 5/16	35 5/8	39 3/8	41 5/8
E	5	55	54 1/2	55 1/4	56	54 1/2	63
S	6	93 7/8	97 3/8	98 5/8	105 1/4	110	121
I	7	12	12	12	18	18	18
O	8	11 1/16	10 3/8	9 1/4	13 11/16	12	15 1/4
N	9	9 15/16	10 5/8	11 3/4	13 5/16	15	14 3/4
S	10	1 3/8	1 1/2	2 1/16	2 1/2	3 1/16	3 1/8
	11	4 13/16	4 13/16	5 9/16	7 15/16	7 15/16	7 3/16
INLET PIPE SIZE		2 1/2 FLG.	2 1/2 FLG.	3 FLG.	4 FLG.	4 FLG.	5 FLG.
OUTLET PIPE SIZE		2 1/2 FLG.	2 1/2 FLG.	3 FLG.	4 FLG.	4 FLG.	5 FLG.

'A' VALVE SIZE	ITEM	VALVE SIZE AND OVERALL LOCATION						
1/2"	'B'	30 3/4	33 1/8	33 1/4	37 9/16	36 5/16	37 3/4	38 1/4
	'C'	16 3/16	16 7/16	17 7/16	19 15/16	21 7/16	23 7/16	25 7/16
3/4"	'B'	30 3/4	33 1/8	33 1/4	37 9/16	36 5/16	37 3/4	38 1/4
	'C'	16 3/16	16 7/16	17 7/16	19 15/16	21 7/16	23 7/16	25 7/16
1"	'B'	30 3/4	33 1/8	33 1/4	37 9/16	36 5/16	37 3/4	38 1/4
	'C'	17 3/16	17 7/16	18 7/16	20 15/16	22 7/16	24 7/16	26 7/16
1 1/4"	'B'	31 3/8	33 3/4	33 7/8	38 3/16	36 15/16	38 3/8	38 7/8
	'C'	18 1/2	18 3/4	19 3/4	22 1/4	23 3/4	25 3/4	27 3/4
1 1/2"	'B'	31 3/8	33 3/4	33 7/8	38 3/16	36 15/16	38 3/8	38 7/8
	'C'	18 1/2	18 3/4	19 3/4	22 1/4	23 3/4	25 3/4	27 3/4
2"	'B'	31 3/8	33 3/4	33 7/8	38 3/16	36 15/16	38 3/8	38 7/8
	'C'	19 7/16	19 11/16	20 11/16	23 3/16	24 11/16	26 11/16	28 11/16
2 1/2"	'B'	33 3/16	35 9/16	35 11/16	40	38 3/4	40 3/16	40 11/16
	'C'	19 3/8	19 5/8	20 5/8	23 1/8	24 5/8	26 5/8	28 5/8
3"	'B'	N/A	35 9/16	35 11/16	40	38 3/4	40 3/16	40 11/16
	'C'		19 5/8	20 5/8	23 1/8	24 5/8	26 5/8	28 5/8
4"	'B'	N/A	N/A	34 11/16	39	37 3/4	39 3/16	39 11/16
	'C'			20 11/16	23 3/16	24 11/16	26 11/16	28 11/16
5"	'B'	N/A	N/A	N/A	39	37 3/4	39 3/16	39 11/16
	'C'				23 3/16	24 11/16	26 11/16	28 11/16

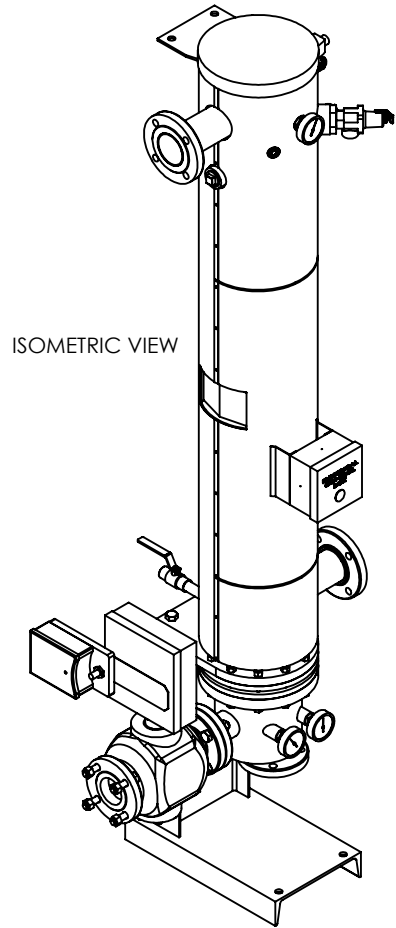

NOTES:

- 1/ DIMENSIONS IN INCHES, AND SUBJECT TO CHANGE WITHOUT NOTICE.
- 2/ DIM 'B', 'C' ARE TO BE APPROXIMATED ONLY, CONSULT FACTORY FOR TIGHT DIMENSIONS.

<b>Ace Heaters, LLC</b> www.aceheaters.com		
This document contains proprietary information from AHS, LLC. Do not reproduce or distribute without prior written consent of AHS, LLC.	ASME Section VIII Div 1: 2015 Ed. Design Pressure: 150 psig Test Pressure: 195 psig Max Design Temperature: 370°F	A.I.
SCALE: NA	Filename: SIVDW	SHEET 1 OF 1
Dwg By: JL	Orig Date: 12/17/15	Rev Date:      Checked By:
<b>MINIPACK SYSTEM - VERTICAL DW</b> Water 2w - Warren Electric Valve Package		
Dwg #: SIVDWWE-2W-WARREN-DIM	SO:	REV 1