

Shell Sizes	DIMENSIONS						
	1	2		3	4	Leg QTY.	
		Pipe Legs w/ Pads	Angle Legs w/ Pads			Pipe Legs w/ Pads	Angle Legs w/ Pads
1802	36						
1803	48						
1804	60	8	8	18	38 MAX	3	3
1805	72						
2404	63						
2405	75	8 1/2	8	24	50 MAX	3	3
2406	87						
2407	99						
3004	66						
3005	78	11	8	30	58 MAX	3	3
3006	90						
3007	102						
3604	69						
3605	81	9 1/2	8	36	66 MAX	3	3
3606	93						
3607	105						
3608	117						
4204	72						
4205	84	13 1/2	8	42	72 MAX	3	3
4206	96						
4207	108						
4208	120						
4804	75						
4805	87	13	8	48	78 MAX	3	4
4806	99						
4807	111						
4808	123						
5405	91						
5406	103	11	8	54	84 MAX	3	4
5407	115						
5408	127						
6005	93						
6006	105	11	8	60	90 MAX	4	4
6007	117						
6008	129						
6009	141						
6605	95						
6606	107	12	8	66	96 MAX	4	4
6607	119						
6608	131						
6609	143						
7205	98						
7206	110	12 1/2	8	72	102 MAX	4	4
7207	122						
7208	134						
7209	146						

LINING
<input type="checkbox"/> GLASS
<input type="checkbox"/> CEMENT
<input type="checkbox"/> PREKRETE
<input type="checkbox"/> NONE
<input type="checkbox"/> OTHER _____

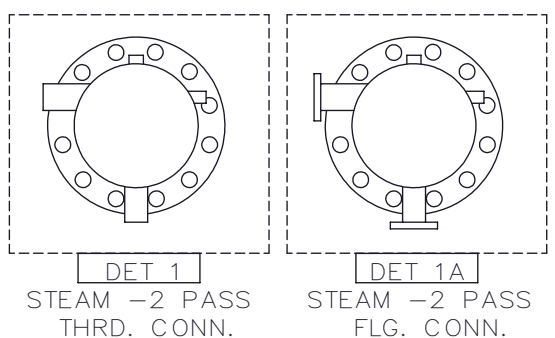

USE DET 1 or DET 1A

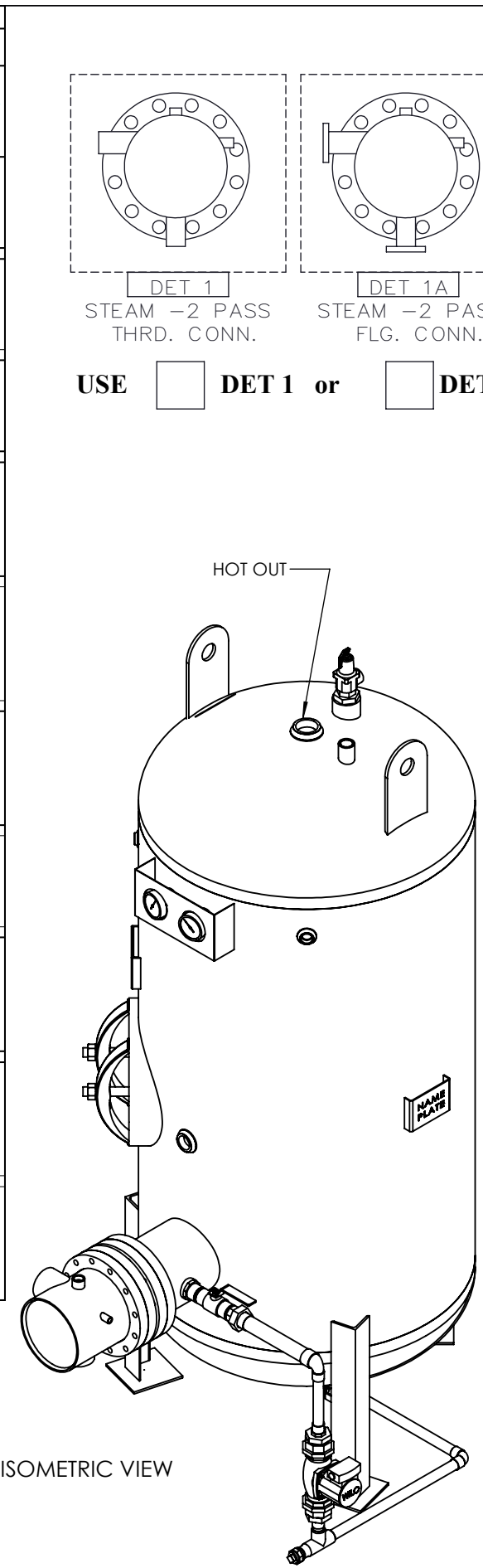
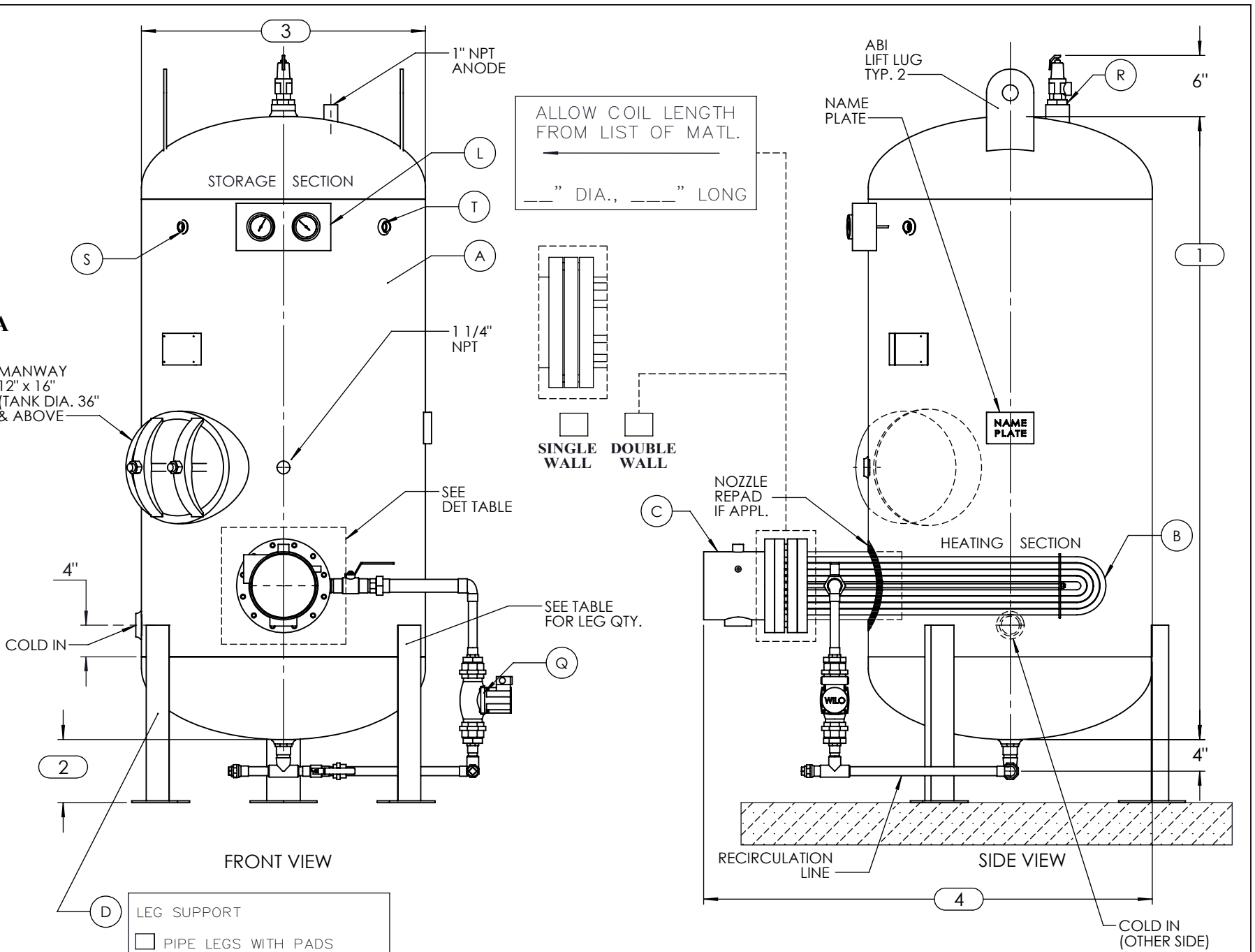

NOTES:
1. REFER TO "LIST OF MATERIALS" FOR DESCRIPTION OF LETTERED ITEMS.
2. ALL COMPONENTS SHOWN ARE PREWIRED AND/OR PREPARED BY ACE HEATERS. CUSTOMER NEEDS ONLY TO PLUMB WATER TO BE HEATED, STEAM AND CONDENSATE LINES, AND BRING ELECTRICITY TO THE CONTROL BOX.
3. ALL DIMENSIONS ARE IN INCHES AND SUBJECT TO CHANGE WITHOUT NOTICE.

 U W	CERTIFIED BY _____		Ace Heaters	
	MAXIMUM ALLOWABLE WORKING PRESSURE			
	SHELL	150	PSI @	390 °F
	TUBES	150	PSI @	390 °F
	MIN. D.M.T.	0	°F @	150 PSI
S/N	YEAR BUILT			
MODEL	_____			
CAPACITY	_____	GAL SA.	_____	SQFT
JOB NO.	_____			XXX
ACE HEATERS				
This document contains proprietary information from ACE HEATERS. Do not reproduce or distribute without prior written consent of ACE HEATER		ASME Section VIII Div 1: . Design Pressure: 150 psig Test Pressure: 195 psig Max Design Temperature: 390°F		A.I:
SCALE: N/A	Filename: GVS-PUMP			
Dwg By:	Orig Date:	Rev Date:	Checked By:	
Vertical Unpackaged Storage Water Heater Steam 2P -with Recirc.- No Ins.- No Skid				
Dwg #: GVS-PUMP	SO:			REV. 1