

ALLOW COIL LENGTH FROM LIST OF MATL.  
 \_\_\_\_" DIA., \_\_\_\_" LONG

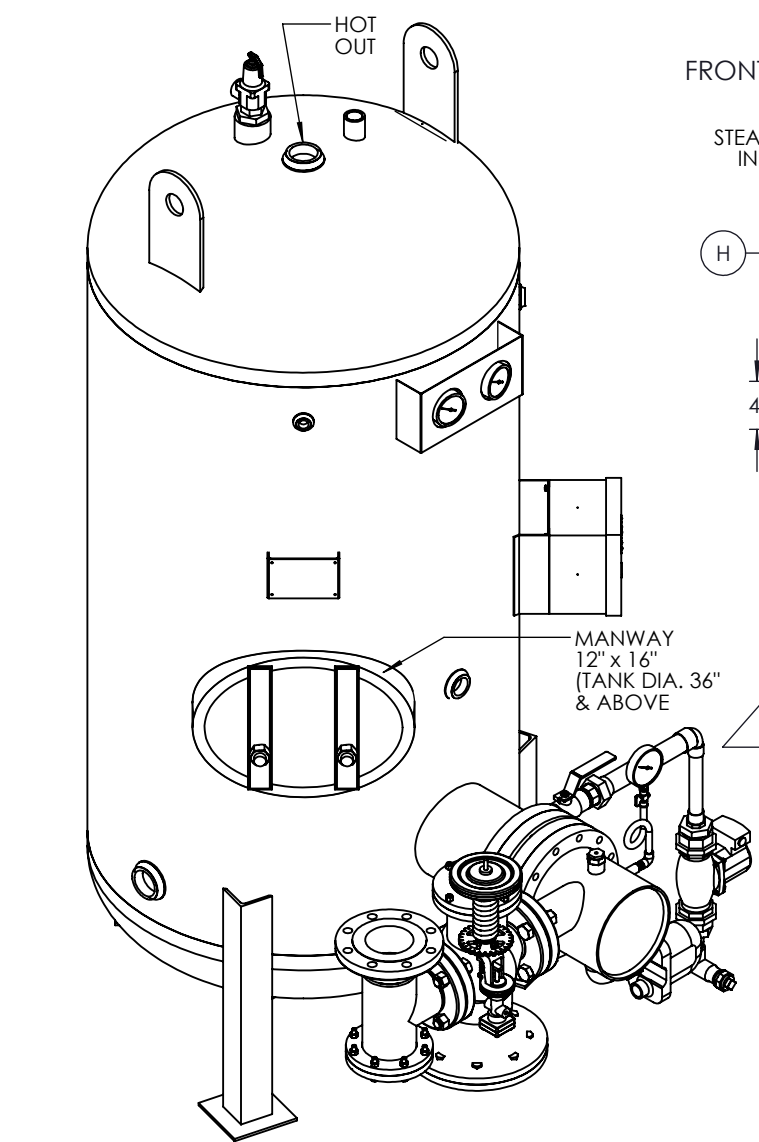
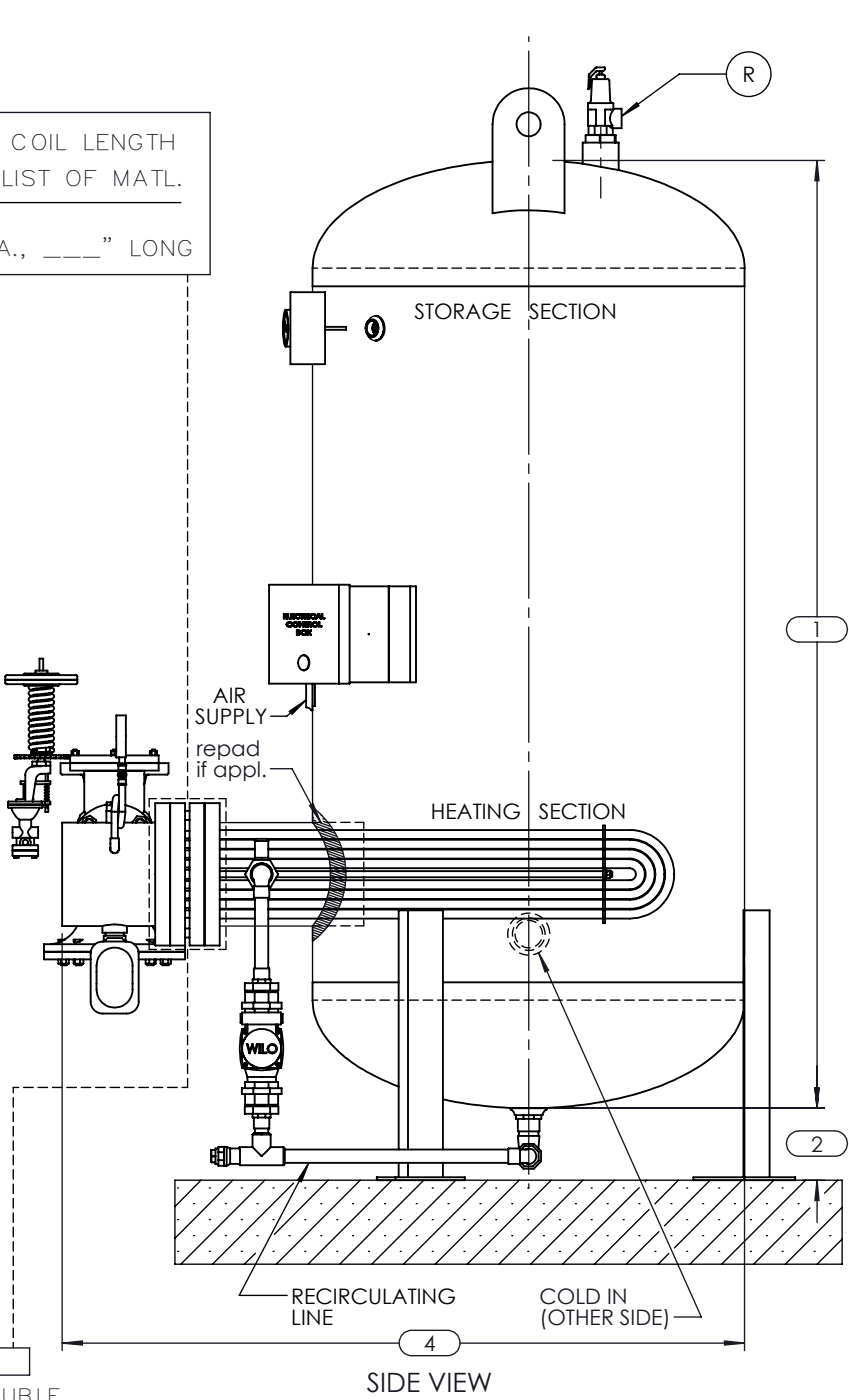

- LEG SUPPORT
- PIPE LEGS WITH PADS
  - ANGLE LEGS WITH PADS (AS SHOWN)
  - OTHER: SEISMIC

- USE  SINGLE WALL  DOUBLE WALL
- DET 1 or  DET 1A

- LINNING
- GLASS
  - CEMENT
  - PREKRETE
  - NONE
  - OTHER\_\_\_\_\_

Shell Sizes	DIMENSIONS						
	1	2		3	4	Leg QUANTITY	
		Pipe Legs with Pads	Angle Legs with Pads			Pipe Legs with Pads	Angle Legs with Pads
1802	36						
1803	48						
1804	60						
1805	72						
2404	63						
2405	75						
2406	87						
2407	99						
3004	66						
3005	78						
3006	90						
3007	102						
3604	69						
3605	81						
3606	93						
3607	105						
3608	117						
4204	72						
4205	84						
4206	96						
4207	108						
4208	120						
4804	75						
4805	87						
4806	99						
4807	111						
4808	123						
5405	91						
5406	103						
5407	115						
5408	127						
6005	93						
6006	105						
6007	117						
6008	129						
6009	141						
6605	95						
6606	107						
6607	119						
6608	131						
6609	143						
7205	98						
7206	110						
7207	122						
7208	134						
7209	146						

NOTES:

- REFER TO "LIST OF MATERIALS" FOR DESCRIPTION OF LETTERED ITEMS.
- ALL COMPONENTS SHOWN ARE PREWIRED AND/OR PREPIPED BY ACE HEATERS. CUSTOMER NEEDS ONLY TO PLUMB WATER TO BE HEATED, STEAM AND CONDENSATE LINES, AND BRING ELECTRICITY TO THE CONTROL BOX.
- DIMENSION 4 IS APPROXIMATE ONLY. CONSULT FACTORY FOR TIGHT DIMENSIONS.
- ALL DIMENSIONS ARE IN INCHES AND SUBJECT TO CHANGE WITHOUT NOTICE.

CERTIFIED BY \_\_\_\_\_

**Ace Heaters**

MAXIMUM ALLOWABLE WORKING PRESSURE

SHELL 150 PSI @ 390 °F

TUBES 150 PSI @ 390 °F

MIN. D.M.T. 0 °F @ 150 PSI

S/N \_\_\_\_\_ YEAR BUILT \_\_\_\_\_

MODEL \_\_\_\_\_

CAPACITY \_\_\_\_\_ GAL SA. \_\_\_\_\_ SQFT

JOB NO. \_\_\_\_\_ XXX

**ACE HEATERS**

This document contains proprietary information from Ace Heaters. Do not reproduce or distribute without prior written consent of Ace Heaters

ASME Section VIII Div 1:  
 Design Pressure: 150 psig  
 Test Pressure: 195 psig  
 Max Design Temperature: 390 °F

A.I.:

SCALE: N/A      Filename: PVSP-LINS      SHEET 1 OF 1

Dwg By:      Orig Date:      Rev Date:      Checked By:

**VERTICAL PACKAGED STORAGE WATER HEATER**  
 STEAM - PILOT OPERATED PACKAGE - NO SKID - LESS INS.

Dwg #: PVSP-LINS      SO:      REV. 1