

COVER DRAWING FOR SJ SERIES TANK

JOB: _____ REP.: _____

QTY. REQ'D.: _____ ENG.: _____

SPECIFICATIONS:

MODEL : ACE "SJ" STORAGE TANK
 CONFORMS TO : ASME CODE, SECTION VIII, DIV. 1
 RATING : 150 PSI @ 390° F
 SHELL / HEADS : CARBON STEEL

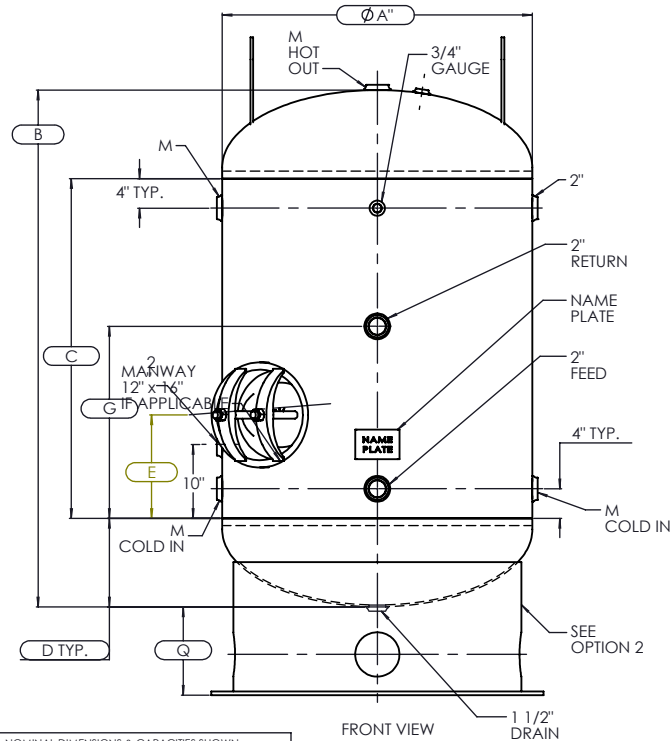
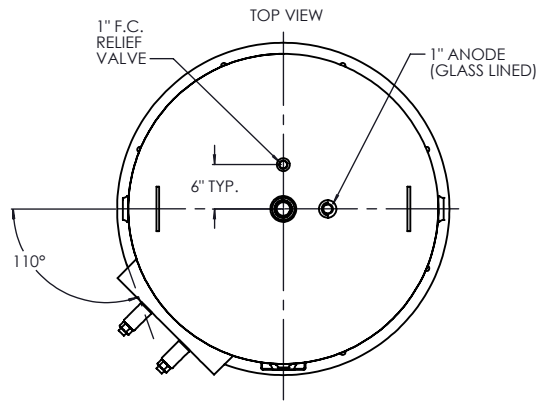

CAPACITY	-A- TANK DIAMETER, inches										
	18	24	30	36	42	48	54	60	66	72	
-B- O.A.H.	02	36" 36 GAL.									
	03	48" 49 GAL.									
-C- SHELL LENGTH, feet	04	60" 62 GAL.	63" 117 GAL.	66" 190 GAL.	69" 275 GAL.	72" 390 GAL.	75" 510 GAL.				
	05	72" 75 GAL.	75" 140 GAL.	78" 225 GAL.	81" 325 GAL.	84" 460 GAL.	87" 605 GAL.	90" 740 GAL.	93" 940 GAL.	96" 1155 GAL.	99" 1405 GAL.
	06		87" 163 GAL.	90" 260 GAL.	93" 375 GAL.	96" 530 GAL.	99" 700 GAL.	102" 860 GAL.	105" 1085 GAL.	108" 1330 GAL.	111" 1615 GAL.
	07		99" 186 GAL.	102" 295 GAL.	105" 425 GAL.	108" 600 GAL.	111" 795 GAL.	114" 980 GAL.	117" 1230 GAL.	120" 1505 GAL.	123" 1825 GAL.
	08				117" 475 GAL.	120" 670 GAL.	123" 890 GAL.	126" 1100 GAL.	129" 1375 GAL.	132" 1680 GAL.	135" 2035 GAL.
	09								141" 1520 GAL.	144" 1855 GAL.	147" 2245 GAL.
	09										

HEAD DEPTH	D	6"	7 1/2"	9"	10 1/2"	12"	13 1/2"	15"	16 1/2"	18"	19 1/2"
CONN. SIZE	M	1 1/2"	1 1/2"	2"	2"	2"	3"	3"	3"	3"	3"
LOCATION	E	---	---	---	---	14"	14"	14"	16"	16"	16"
INSPECT OPENING		2"	2"	2"	2"	12"x16" MANWAY	12"x16" MANWAY	12"x16" MANWAY	12"x16" MANWAY	12"x16" MANWAY	12"x16" MANWAY
RETURN UPPER	G	14"	← 26" →								
TANK CLEAR.	Q	11"	11"	11"	11"	11"	11"	11"	13 1/2"	13 1/2"	13 1/2"

OPTIONS:

1. INTERIOR LINING :

- NONE (390° F MAX.)
 - WITH CARBON STEEL FITTINGS, FPT
 - WITH 304 S.S. FITTINGS, FPT
- GLASS (160° F MAX.), UP TO 8 ft LONG TANK
 - WITH CARBON STEEL FITTINGS, FPT
 - WITH 304 S.S. FITTINGS, FPT
- CEMENT (180° F MAX.), DIA 30" TANK & ABOVE
 - WITH CARBON STEEL FITTINGS, FPT
 - WITH 304 S.S. FITTINGS, FPT
- PREKRETE (350° F MAX.), DIA 30" TANK & ABOVE
 - WITH CARBON STEEL FITTINGS, FPT
 - WITH 304 S.S. FITTINGS, FPT
- OTHER _____

2. SUPPORTS:

- RING BASE W/BASE PLATE (SHOWN)

NOTE:

ALL DIMENSIONS IN INCHES AND SUBJECT TO CHANGE WITHOUT NOTICE
 ** = RT-4 FOR SJ6009,
 30" AND 36" DIA. TANKS WILL REQUIRE AN 11"x15" MWY WHEN CEMENT OR PRE-KRETE LINED

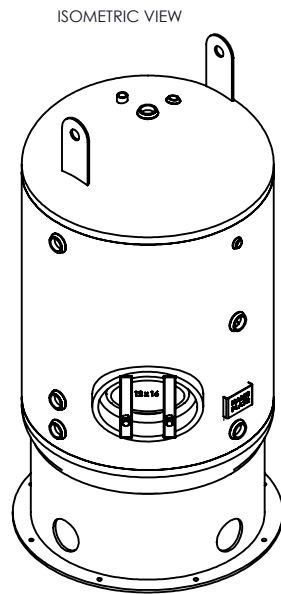

NB
 CERTIFIED BY
ACE HEATERS

SH 150 PSI @ 390 °F
 TUBES XXX PSI @ XXX °F
 MIN. D.M.T. °F @ 150 PSI

S/N _____ YEAR BUILT _____
 MODEL _____
 CAPACITY _____ GAL SA. _____
 JOB NO. _____ XXX _____

ACE HEATERS

This document contains proprietary information from ACE HEATERS. Do not reproduce or distribute without prior written consent of ACE HEATERS.

ASME Section VIII Div 1:
 Design Pressure: 150 psig
 Test Pressure: 195 psig (150 psi / glass)
 Max Design Temperature: 390°F

A.I:

SCALE: NA Filename: SJ TANK - COVER DRAWING SHEET 1 OF 1

Dwg By: _____ Orig Date: _____ Rev Date: _____ Checked By: _____

**SEC. VIII DIV 1, 150 PSI SJ TANK, COVER DRAWING
 VERTICAL - RING BASE SUPPORT**

Dwg #: SJ-A-V040 SO: _____ REV _____