

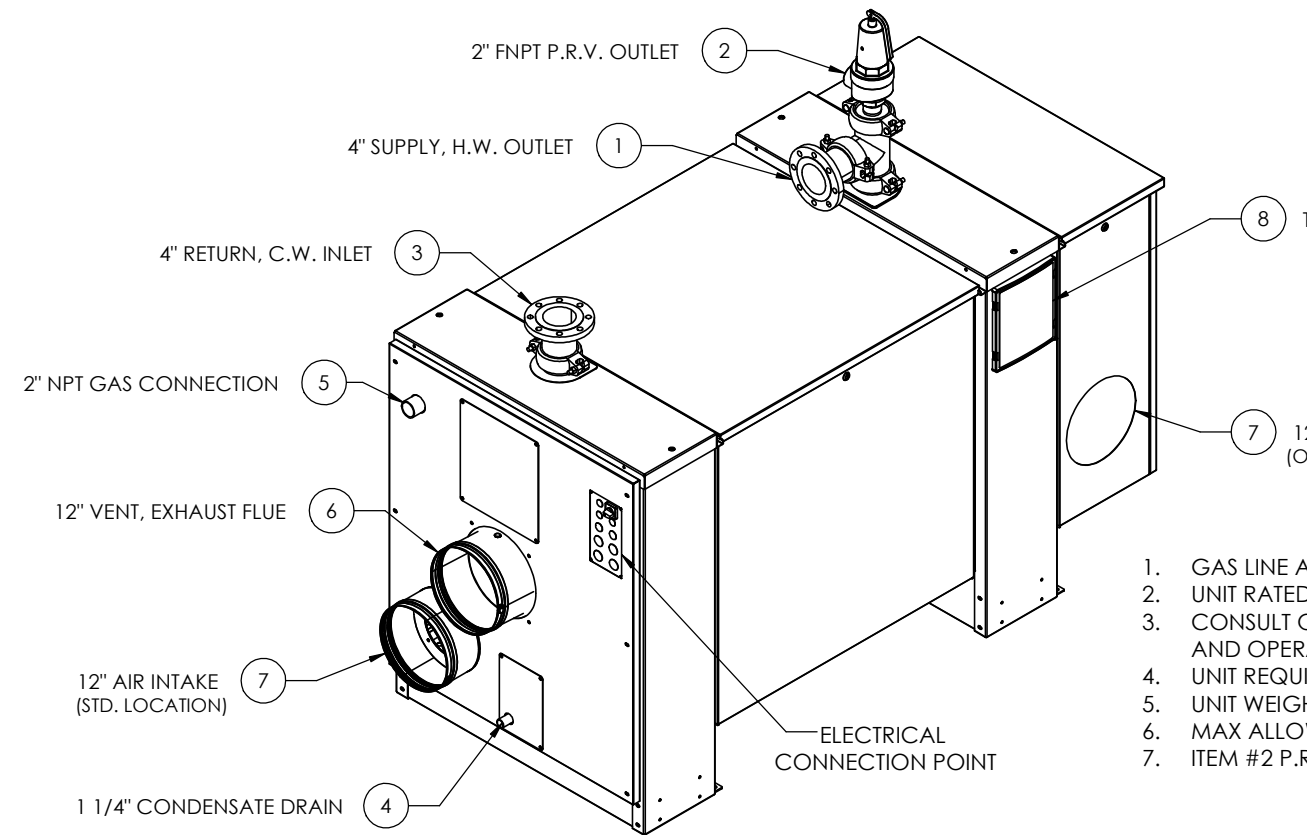

ITEM NO	QTY.	PART NO.	MATERIAL	SIZE	DESCRIPTION
1	1	---	316 SS	4" ANSI RF FLG	SUPPLY, H.W. OUTLET
2	1	---	VARIOUS	2" FNPT	PRESSURE RELIEF VALVE
3	1	---	316 SS	4" ANSI RF FLG	RETURN, C.W. INLET
4	1	---	CPVC	1 1/4"	CONDENSATE DRAIN
5	1	---	STEEL	2" NPT	GAS CONNECTION
6	1	---	316 SS	12"	VENT, EXHAUST FLUE
7	1	---	316 SS	12"	AIR INTAKE (STD. & OPT. LOCATION)
8	1	---	VARIOUS	---	DISPLAY, TEMPERATURE CONTROLLER

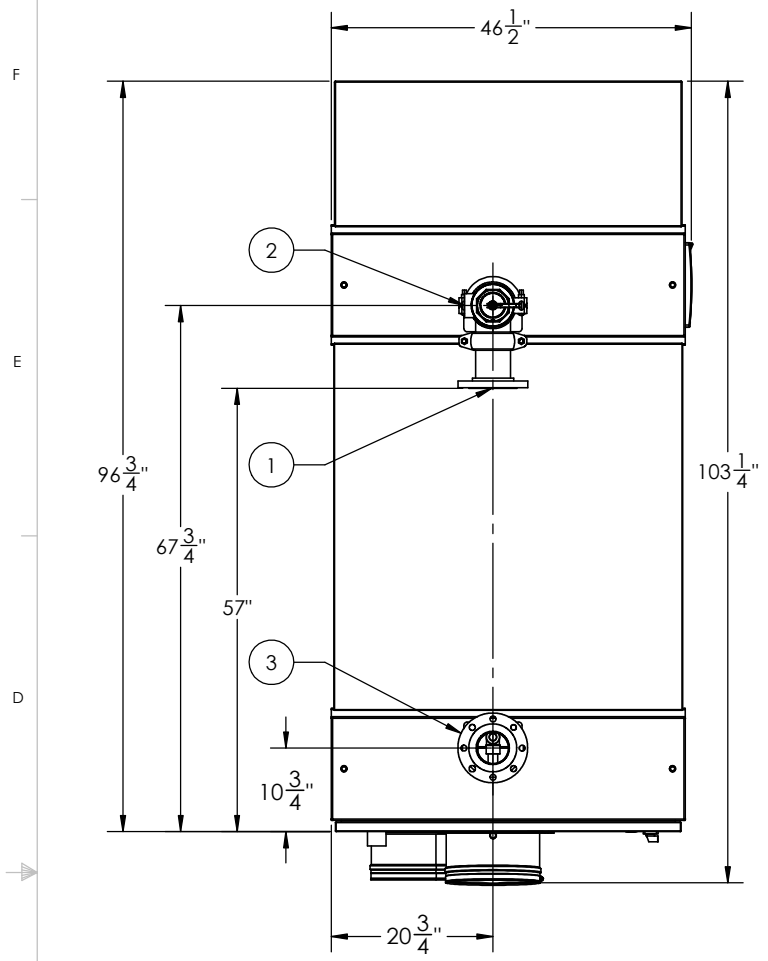

1. GAS LINE AND VENT PIPING TO BE SUPPLIED BY OTHERS
2. UNIT RATED FOR 4000 mBTU/HR
3. CONSULT O&M MANUAL FOR INSTALLATION REQUIREMENTS AND OPERATING PARAMETERS
4. UNIT REQUIRES 480V/3Ph/60Hz SUPPLY
5. UNIT WEIGHS APPROX. 2314 LBS DRY, 2692 LBS WET
6. MAX ALLOWABLE WORKING PRESSURE 145 PSI
7. ITEM #2 P.R.V. SHIPPED LOOSE

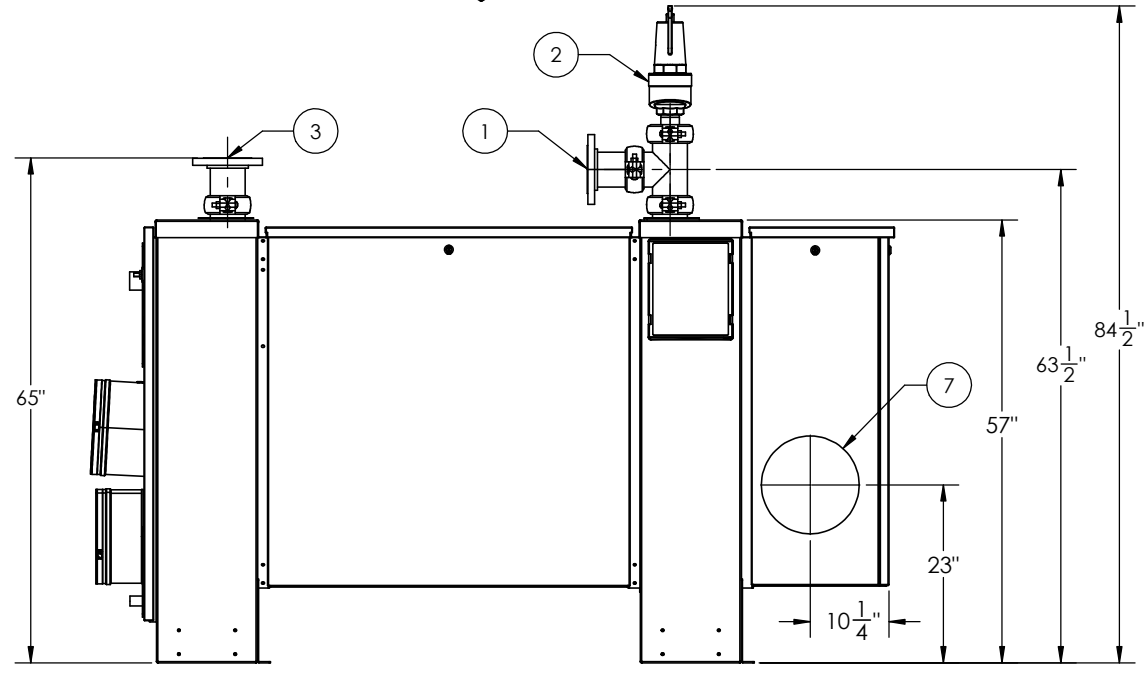
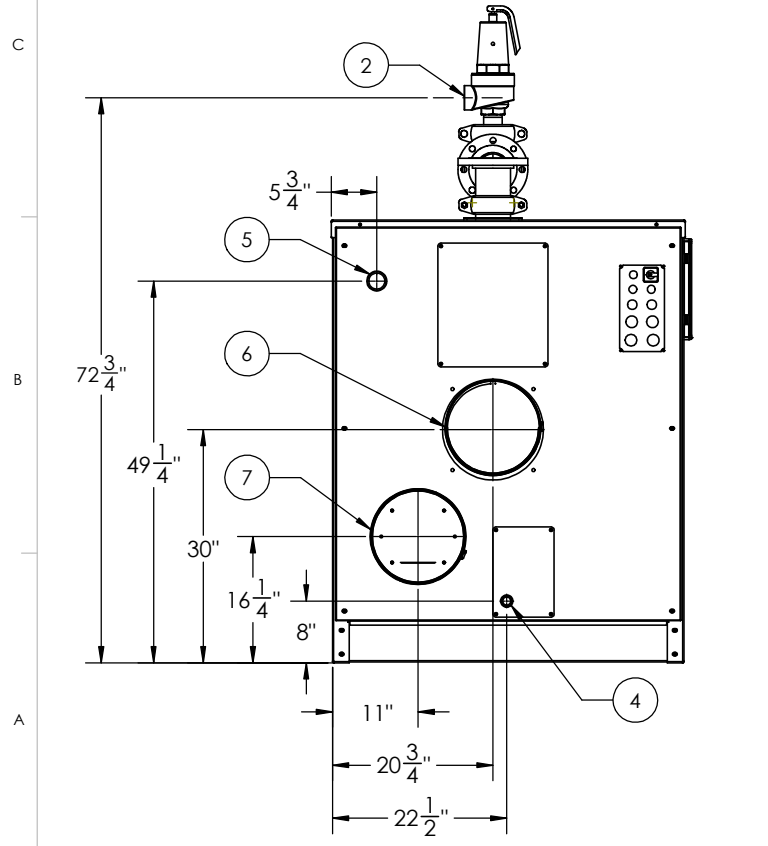

ZONE	REV.	DESCRIPTION	DATE	APPROVED
REVISIONS				
DRAWN	11/1/2023	RC		
CHECKED	01/12/2024	TWG		
ENG APPR.				
MFG APPR.				

Customer:			
Description:		MODEL E-4000WH 4,000,000 BTU GAS HEATER 480VAC - 3Φ - 60Hz	
SIZE	DWG. NO.	REV	
C	AJAX E 4000	-	
SCALE: 1:16		FSCM: 19857	SHEET 1 OF 1

PROPRIETARY AND CONFIDENTIAL
 THE INFORMATION CONTAINED IN THIS DRAWING IS THE SOLE PROPERTY OF THE ELECTRIC HEATER COMPANY. ANY REPRODUCTION IN PART OR AS A WHOLE WITHOUT THE WRITTEN PERMISSION OF THE ELECTRIC HEATER COMPANY IS PROHIBITED.

DIMENSIONS ARE IN INCHES
 TOLERANCES:
 (UNLESS OTHERWISE SPECIFIED)
 FRACTIONAL: ±1/16"
 ANGULAR: MACH ±1/2° BEND ±1°
 TWO PLACE DECIMAL: ±0.01
 THREE PLACE DECIMAL: ±0.005