



Liberty US 200 - 800 Boiler

Operating and Maintenance Manual



Model Numbers: US400H - US800H

Version Date: March 2024

INSTALLATION AND OPERATION INSTRUCTIONS FOR Liberty *BOILER*

TABLE OF CONTENTS

1.0	INTRODUCTION	3
2.0	INTRODUCTION	6
3.0	WATER HEATER LOCATION	8
4.0	GENERAL VENTING	12
5.0	VENT AND AIR-INTAKE TERMINATION CLEARANCES.....	26
6.0	CONDENSATE DRAIN	30
7.0	INSTALLING GAS PIPING	31
8.0	LIGHTING THE WATER HEATER.....	33
9.0	GAS VALVE AND BURNER SET-UP.....	35
10.0	WATER HEATER PIPING.....	41
11.0	LEAD LAG INSTRUCTIONS.....	49
12.0	FIELD WIRING	52
13.0	WIRING SCHEMATICS.....	58
14.0	INSTALLATION CHECKLIST.....	62
15.0	ANNUAL MAINTENANCE AND INSPECTION.....	63
16.0	PARTS LIST.....	65
17.0	TROUBLESHOOTING.....	76

HAZARD SYMBOLS AND DEFINITIONS



Danger Sign: Indicates a hazardous situation which, if not avoided, will result in serious injury or death.



Warning Sign: Indicates a hazardous situation which, if not avoided, could result in serious injury or death.



Caution Sign plus Safety Alert Symbol: Indicates a hazardous situation which, if not avoided, could result in minor or moderate injury.



Caution Sign without Safety Alert Symbol: Indicates a hazardous situation which, if not avoided, could result in property damage.



Notice Sign: Indicates a hazardous situation which, if not avoided, could result in property damage.



This Water Heater must be installed by a licensed and trained Heating Technician or the **Warranty is Void**. Failure to properly install this unit may result in property damage, serious injury to occupants, or possibly death.

Read Before Proceeding

If you do not follow these instructions exactly, a fire or explosion may result causing property damage, serious injury or death.

FOR YOUR SAFETY, READ BEFORE OPERATING

- A) This boiler does not have a pilot. It is equipped with an ignition device which automatically lights the burner. Do not try to light the burner by hand.
- B) BEFORE OPERATING smell all around the boiler area for gas. Be sure to smell next to the floor because some gas is heavier than air and will settle on the floor.
WHAT TO DO IF YOU SMELL GAS:
 - Do not try to light any appliance.
 - Do not touch any electric switch.
 - Do not use any phone in your building.
 - Immediately call your gas supplier from a neighbor's phone. Follow the gas supplier's instructions.
 - If you cannot reach your gas supplier, call the fire department.
- C) Use only your hand to push in or turn the gas control knob. Never use tools. If the knob will not push in or turn by hand, don't try to repair it, call a qualified service technician. Force or attempted repair may result in a fire or explosion.
- D) Do not use this boiler if any part has been under water. Immediately call a qualified service technician to inspect the boiler and to replace any part of the control system and any gas control which has been under water.

OPERATING INSTRUCTIONS

1. STOP! Read the safety information above very carefully.
2. Set the thermostat to lowest setting. Turn off all electric power to the boiler.
3. This boiler does not have a pilot. It is equipped with an ignition device which automatically lights the burner. Do not try to light the burner by hand.
4. Turn the manual gas valve to the OFF position. Remove front access panel.
5. Wait five (5) minutes to clear out any gas. Then smell for gas, including near the floor. If you smell gas, STOP! Follow "B" in the safety information above. If you don't smell gas, go to the next step.
6. Turn the manual gas valve ON. Wait an additional five (5) minutes smelling for gas.
7. Replace the front access panel.
8. Set thermostat to highest setting. Turn on all electric power to the boiler.
9. Ignition sequence is automatic. Combustion will occur after a brief fan purge.
10. If ignition does not occur, follow the instructions "To Turn Off Gas To Boiler" and call your service technician or gas supplier.

TO TURN OFF GAS TO THE BOILER

1. STOP! Read the safety information above very carefully.
2. Turn off all electric power to the boiler
3. Turn the manual gas valve to the OFF position



Crystalline Silica - Certain components confined in the combustion chamber may contain this potential carcinogen. Improper installation, adjustment, alteration, service or maintenance can cause property damage, serious injury (exposure to hazardous materials) or death. Refer to Section 15.0 for information on handling instructions and recommended personal protective equipment. Installation and service must be performed by a qualified installer, service agency or the gas supplier (who must read and follow the supplied instructions before installing, servicing, or removing this boiler. This boiler contains materials that have been identified as carcinogenic, or possibly carcinogenic, to humans).



Void Warranty - This Boiler must have water flowing through it whenever the burner is on or it will damage the unit and void the warranty. Failure to follow these instructions may result in serious injury or death.

1.0 INTRODUCTION

General Installation Requirements

The installation of your Liberty US boiler must conform to the requirements of this manual, your local authority, and the National Fuel Gas Code ANSI Z223.1 and or CAN/CGA B149 Installation Codes. Where required by the Authority, the installation must conform to the standard for “Controls and Safety Devices for Automatically Fired Boilers ANSI/ASME CSD-1.

This document pertains to the correct installation and operation of Liberty US boiler models US400, US500, US 600, US 700 and US 800. The instructions detailed in this document supersede any and all previous instructions provided by ACE, written or otherwise. Each unit is provided with the following:

1. Installation and Operating Instructions,
2. Appendix A – Controller and Touchscreen Display Instructions,
3. Liberty US User’s Manual, and
4. Natural Gas to LP Conversion Kit*

* The conversion kit is required to convert the boiler so it will safely operate with Propane Gas.



Models *US* 600-800 are not approved for operation with Propane (LP Gas). Operating these models with Propane will result in property damage, serious injury or death.



Read and understand this entire document prior to proceeding with the installation of the *Liberty US*. Failure to follow the instructions outlined in this document will result in property damage, serious injury or death.



Energy Saving Feature - This boiler is equipped with a feature that saves energy by reducing the boiler water temperature as the heating load decreases. This feature is equipped with an override which is provided primarily to permit the use of an external energy management system that serves the same function. **THIS OVERRIDE MUST NOT BE USED UNLESS AT LEAST ONE OF THE FOLLOWING CONDITIONS IS TRUE:**

- An external energy management system is installed that reduces the boiler water temperature as the heating load decreases.
- This boiler is not used for any space heating.
- This boiler is part of a modular or multiple boiler system having a total input of 400,000 BTU/hr or greater.
- This boiler is equipped with a tankless coil.

User Responsibilities

This boiler must be installed and serviced by a qualified installer or service technician. This boiler must be serviced and inspected annually when operating in normal residential applications. Demanding applications or extreme conditions (i.e. commercial) may require more frequent service and inspection. As the User/Owner of this equipment, you are responsible for ensuring the maintenance is performed at the required intervals (see Section 15 – Annual Maintenance and Inspection).



Failure to have the boiler properly serviced and inspected on a regular basis by a qualified service technician may result in property damage, serious injury or death.



Failure to keep the Vent and Combustion Air-inlet clear of ice, snow, and other debris may result in property damage, serious injury, or death.

Installer Responsibilities

A qualified installer is a licensed person who has appropriate training and a working knowledge of the applicable codes, regulations, tools, equipment and methods necessary to install a boiler. The Installer assumes all responsibility for a safe installation and that it meets the requirements of the boiler instruction manuals, as well as National and local installation codes. It is also the installer’s responsibility to inform the User/Owner of their obligation with respect to the description under “User Responsibilities”. Failure to follow this warning could result in fire, serious injury, or death.



Failure to use the appropriate Natural to LP Conversion Kit and Orifice when operating the *Liberty US* with Propane will result in extremely dangerous burner operation leading to property damage, serious injury or death. Refer to section titled **ATTENTION: LIQUEFIED PETROLEUM (LP) PROPANE** for applicable conversion kit and LP orifice numbers.

ATTENTION: LIQUEFIED PETROLEUM (LP) PROPANE

The *Liberty US* is factory set to operate with Natural Gas. BEFORE OPERATING WITH PROPANE, the specified LP Conversion Kit and Orifice must be installed to convert the boiler so it will operate safely with LP Propane. The correct kit and LP orifice is listed below (Each kit comes with conversion instructions).

Liquefied Petroleum (LP) propane gas is heavier than air; therefore, it is imperative that your *Liberty US* boiler is not installed in a pit or similar location that will permit heavier than air gas to collect. Local Codes may require boilers fueled with LP gas be provided with an approved means of removing unburned gases from the room. Check your local codes for this requirement.

<u>Model Number</u>	<u>Natural to LP Propane Conversion Kit Kit Number</u>	<u>LP Orifice</u>
US400	ACE-83017-1	62 (6.2mm)
US500	ACE-84386-1	No Orifice

Boiler Vent / Air-Inlet Piping



The Liberty US is certified as a “Category IV” boiler, and requires a “Special Venting System” designed for pressurized venting. The exhaust gases must be piped directly to the outdoors using the vent materials and rules outlined in these instructions. Failure to follow these instructions will result in serious injury or death.

IN THE STATE OF MASSACHUSETTS ONLY

- (a) For all horizontally vented gas fueled equipment installed in every dwelling, building or structure used in whole or in part for residential purposes, including those owned and operated by the Commonwealth and where the side wall exhaust vent termination is less than seven (7) feet above finished grade in the area of the venting, including but not limited to decks and porches, the following requirements shall be satisfied:
1. **INSTALLATION OF CARBON MONOXIDE DETECTORS** At the time of installation of the side wall horizontal vented gas fueled equipment, the installing plumber or gas fitter shall observe that a hard wired carbon monoxide detector with an alarm and battery back-up is installed on the floor level where the gas equipment is to be installed and on each additional level of the dwelling, building or structure served by the equipment. It shall be the responsibility of the property owner to secure the services of qualified licensed professionals for the installation of hard wired carbon monoxide detectors.
 - a. In the event that the side wall horizontally vented gas fueled equipment is installed in a crawl space or an attic, the hard wired carbon monoxide detector with alarm and battery back-up may be installed on the next adjacent floor level.
 - b. In the event that the requirements of this subdivision cannot be met at the time of completion of installation, the owner shall have a period of 30 days to comply with the above requirements; provided, however, that during said 30 day period a battery operated carbon monoxide detector with an alarm shall be installed.
 2. **APPROVED CARBON MONOXIDE DETECTORS** Each carbon monoxide detector as required in accordance with the above provisions shall comply with NFPA 720 and be ANSI/UL 2034 listed and IAS certified.
 3. **SIGNAGE** A metal or plastic identification plate shall be permanently mounted to the exterior of the building at a minimum height of eight (8) feet above grade directly in line with the exhaust vent terminal for the horizontally vented gas fueled heating boiler or equipment. The sign shall read, in print size no less than one-half (1/2) inch in size, "***GAS VENT DIRECTLY BELOW. KEEP CLEAR OF ALL OBSTRUCTIONS***" (*plate included with boiler*).
 4. **INSPECTION** The state or local gas inspector of the side wall horizontally vented gas fueled equipment shall not approve the installation unless, upon inspection, the inspector observes carbon monoxide detectors and signage installed in accordance with the provisions of 248 CMR 5.08(2)(a)1 through 4.
- (b) **EXEMPTIONS:** The following equipment is exempt from 248 CMR 5.08(2)(a)1 through 4:
1. The equipment listed in Chapter 10 entitled "Equipment Not Required To Be Vented" in the most current edition of NFPA 54 as adopted by the Board; and
 2. Product Approved side wall horizontally vented gas fueled equipment installed in a room or structure separate from the dwelling, building or structure used in whole or in part for residential purposes.
- (c) **MANUFACTURER REQUIREMENTS – GAS EQUIPMENT VENTING SYSTEM PROVIDED:** When the manufacturer of Product Approved side wall horizontally vented gas equipment provides a venting system design or venting system components with the equipment, the instructions provided by the manufacturer for installation of the equipment and the venting system shall include:
1. Detailed instructions for installation of the venting system design or the venting system components; and
 2. A complete parts list for the venting system design or venting system.
- (d) **MANUFACTURER REQUIREMENTS – GAS EQUIPMENT VENTING SYSTEM NOT PROVIDED:** When the manufacturer of a Product Approved side wall horizontally vented gas fueled equipment does not provide the parts for venting the flue gases, but identifies "special venting systems", the following requirements shall be satisfied by the manufacturer:
1. The referenced "special venting system" instructions shall be included with the boiler or equipment installation instructions; and
 2. The "special venting system" shall be Product Approved by the Board, and the instructions for that system shall include a parts list and detailed installation instructions.
- (e) A copy of all installation instructions for all Product Approved side wall horizontally vented gas fueled equipment, all venting instructions, all parts list for venting instructions, and/or all venting design instructions shall remain with the boiler or equipment at the completion of the installation.

2.0 INTRODUCTION

Table 2-1 General Specifications

DESCRIPTION				US400	US500	US600	US700 US800
Gas Connection (inches, NPT)				¾" (Female)		1" (Male)	
Water Connections (inches, NPT)				1-1/4" (Female)		2" (Female)	
Exhaust Vent Connection (inches)				4			6
Air-inlet Connection (inches)				4			
Cabinet Height (inches)				36	43	37	
Cabinet Width (inches)	17						
Cabinet Depth (inches)				24	32.5	47.5	63.5
Approximate Weight with water (lbs)				225	320	380	475
Water Content (gallons)				2.4	3.3	4	5.2
Electrical Rating	120V / 1 Phase / 60 Hz / 12A						

Table 2-2 Boiler Performance Specifications

DESCRIPTION	US400	US500	US600	US700	US800			
CSA Input Modulation (MBH) ¹	75 - 399	100 - 500	120 - 600	160 - 700	160 - 800			
DOE Heating Capacity (MBH) ^{1,3}	375	470	564	658	752			
Net I=B=R Rating (MBH) ^{1,3}	326	409	490	572	654			
DOE AFUE (%) ³				-	-	-	-	-
Combustion Efficiency (%) ³	95	95	95	95				
Thermal Efficiency (%) ³	94	94	94	94				

Notes:

¹ Listed Input and Output ratings are at minimum vent lengths at Sea Level. Numbers will be lower with longer venting and/or altitudes greater than 2000 feet [610 m].

³ Based on standard test procedures prescribed by the U.S. Department of Energy. Ratings have been confirmed by AHRI.

High Altitude Operation

The Liberty US is designed to operate at its maximum listed capacity in installations less than or equal to 2000 ft [610 m] above Sea Level. Since the density of air decreases as elevation increases, maximum specified capacity should be de-rated for elevations above 2000 ft [610 m] in accordance with Table 2-3.

Table 2-3 De-rate % for High Altitudes

Elevations	2000 ft [610 m]	3000 ft [914 m]	4000 ft [1219 m]	4500 ft [1372 m]	5000 ft [1524 m]
In Canada ¹	de-rate by 10%	de-rate by 10%	de-rate by 10%	de-rate by 10%	de-rate % may vary
In USA ²	-	de-rate by 12%	de-rate by 16%	de-rate by 18%	de-rate by 20%

Notes:
¹ Canada: Altitudes between 2000-4500 ft [610-1372 m], de-rate by 10%. Consult local authorities for de-rating capacities for altitudes above 4500 ft [1372 m].
² USA: De-rate capacity by 4% for every 1000 ft [305 m], if altitude is over 2000 ft [610 m].



Combustion – At elevations above 2000 feet, the combustion of the boiler must be checked with a calibrated combustion analyzer to ensure safe and reliable operation. **It is the Installers responsibility to check the combustion and to adjust the combustion in accordance to Section 9.0.** Failure to follow these instructions may result in property damage, serious injury, or death.

3.0 BOILER LOCATION

In all cases, the Liberty US must be installed indoors in a dry location where the ambient temperature must be maintained above freezing and below 100°F [38°C]. Gas components must be protected from dripping, spraying water, or rain during operation and servicing. Consider the proximity of system piping, gas and electrical supply, condensate disposal drain, and proximity to vent termination when determining the best boiler location.

**WARNING**

Water or flood damaged components must be replaced immediately with new factory-approved components as failure to do so may result in fire, serious injury, or death.

Floor Mounting

The Liberty US can be mounted directly on combustible flooring, with the exception of carpeting. Installing the boiler on carpeting is not permissible. Ensure the boiler is mounted above any anticipated flood level. Models US400 come equipped with stationary, low profile legs. Models US500-US800 include factory supplied/field installed leveling legs. Once the unit is removed from the pallet, thread the leveling legs into the allocated threaded inserts in the bottom of the unit.

Boiler Area Ventilation Air Openings

Direct Vent – If boiler area clearances are less than the recommended clearances specified in Table 3-1, the boiler area must be ventilated. (**Exception:** if the boiler area/room has a volume of 150 ft³ or greater, ventilation of the boiler room is not required). Each ventilation air opening must meet the minimum requirements of 1 in² per 1000 Btu/hr, but not less than 100 in². The lower ventilation opening must be located within 6” of the floor while the upper opening must be located 6” from the top of the space.

NOTICE

If the "Boiler Area" does not meet the recommended clearances listed in Table 3-1, and if the boiler area has a volume less than 150 ft³, it is considered a Closet or Alcove. PVC vent pipe and fittings shall not be used within the closet or alcove; only approved CPVC, Polypropylene or Stainless Steel vent pipe and fittings can be used. See Table 4-3 for a list of approved materials.

Indoor Combustion Air – When using Indoor Combustion Air in lieu of Direct Vent air-inlet piping (an option for models US500-800), provisions for combustion and ventilation air, in accordance with section “Air for Combustion and Ventilation,” of the *National Fuel Gas Code, ANSI Z223.1/NFPA 54* (U.S.), or Clause 8.2, 8.3 or 8.4 of *Natural Gas and Propane Installation Code, CAN/CSA B149.1* (Canada), or applicable provisions of the local building codes, must be adhered to.

Closet Installations

For closet installations, it is necessary to provide two ventilation air openings as shown in Figure 3-1(a), (b) and (c), each providing a minimum area equal to 1 in² per 1000 Btu/hr, but not less than 100 in² and within 6” of the top and bottom of the closet door. See Table 3-1 for minimum recommended clearances.

Alcove Installations

Alcove installations have the same minimum clearances as closet installations, except the front must be completely open to the room at a distance no greater than 18” [457 mm] from the front of the boiler and the room is at least three (3) times the size of the alcove. Provided these conditions are met, the boiler requires no extra ventilation air openings to the space. See Table 3-1 for minimum recommended clearances.

Residential Garage Installations

When installed in a residential garage, mount the boiler a minimum of 18” [457 mm] above the floor. Locate or protect the boiler so it cannot be damaged by a moving vehicle. Check with your local authorities for other possible regulations pertaining to the installation of a boiler in a garage.

Wall Mounting Installations (Optional)

US400 models are shipped with wall mounting brackets to provide installers with the option of wall mounting the boiler. US500-800 models are not available as a wall mountable unit. Refer to Figures 3-3(a) and 3-3(b) for instructions and illustrations on wall mounting applicable models.

Figure 3-1(a) Closet Installation, Minimum Clearances (US400)

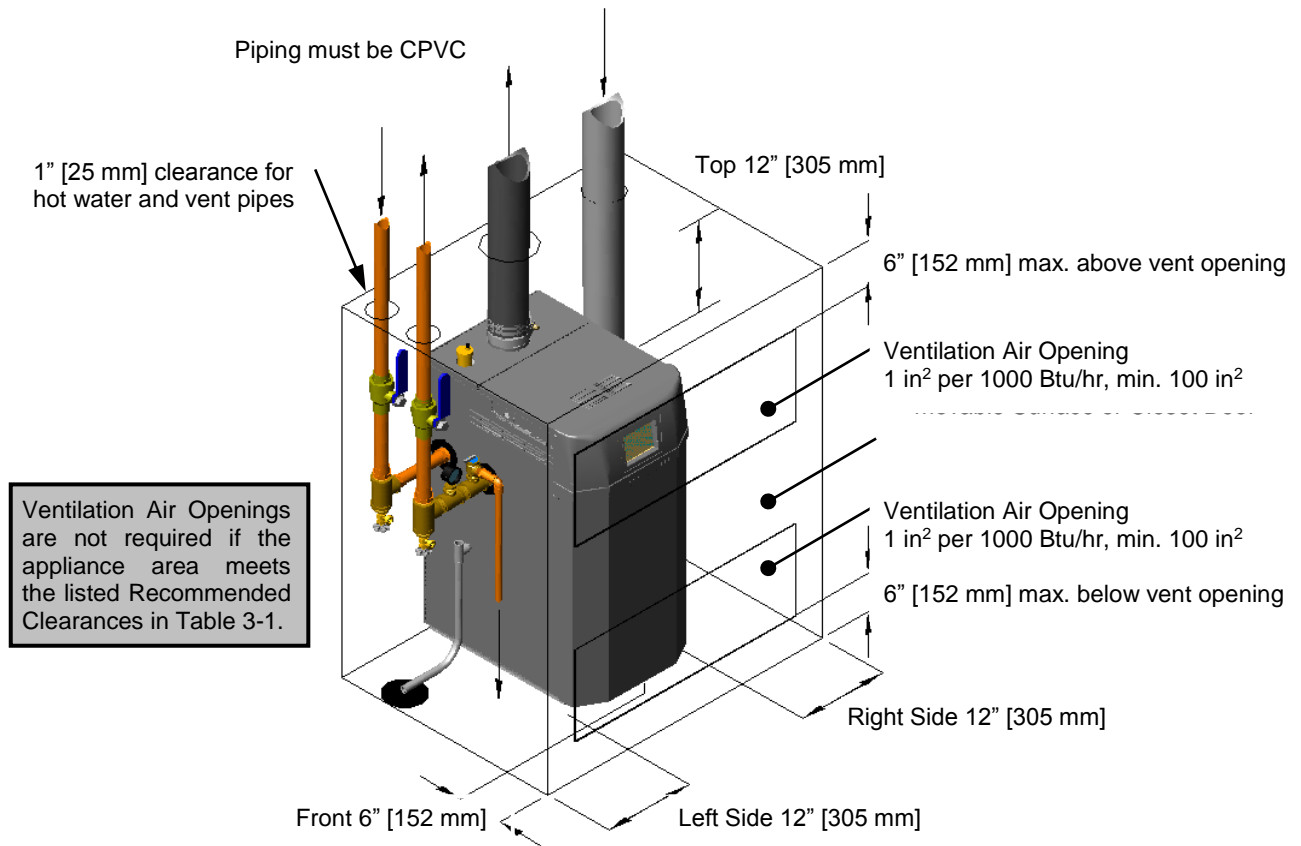

WARNING Closet/alcove installations in US and Canada require approved **CPVC** vent and air-inlet pipe, fittings, cements and primers (Table 4-3).

Figure 3-1(c) Closet Installation, Minimum Clearances (US500-800)

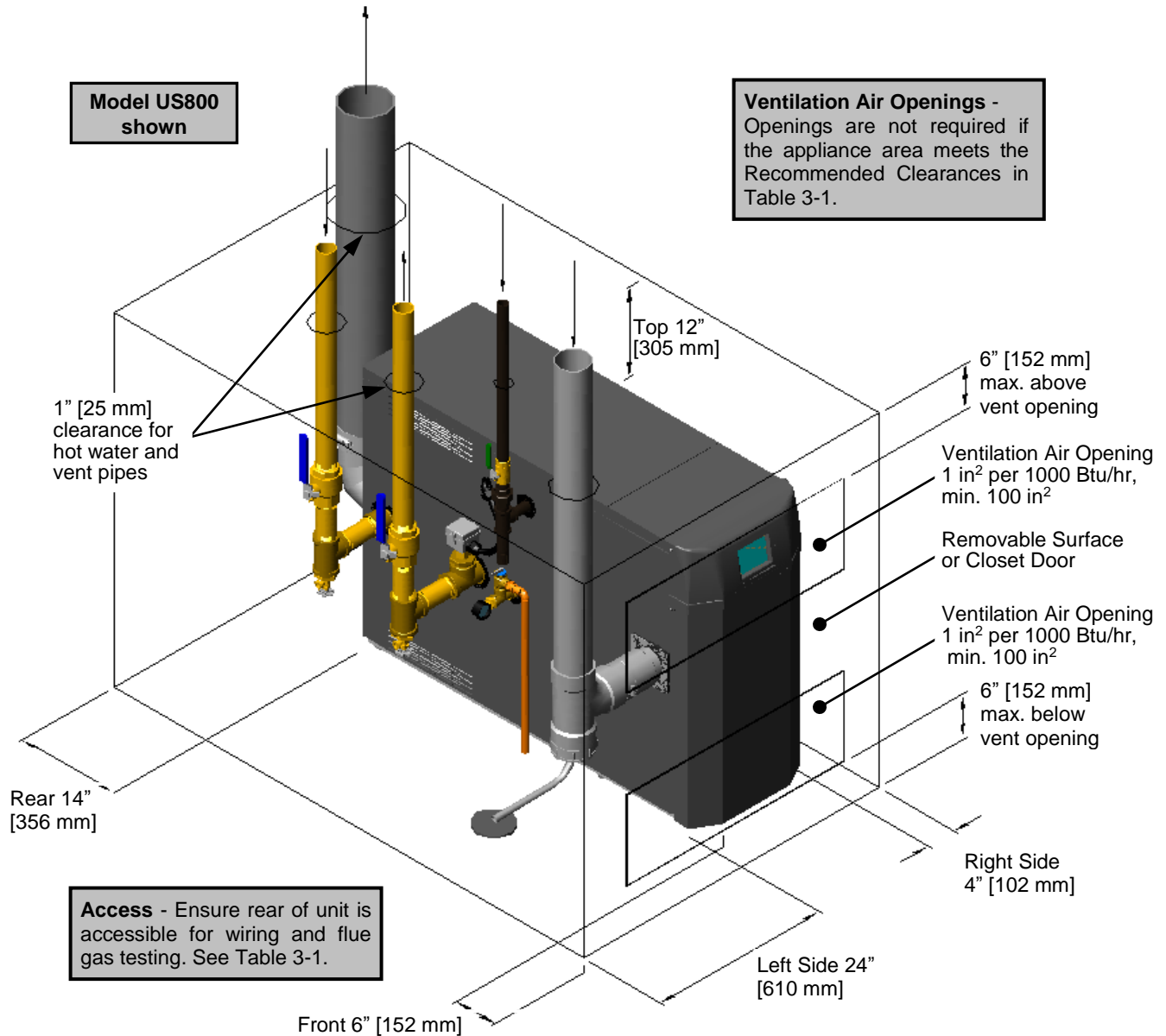

Table 3-1 Minimum Clearances for Installation and Service

Model No.	Clearances	Dimensions - inches					
		Front	Top	Left Side	Right Side	Rear	Flue Pipe
US400	Minimum	24 ¹	12	12	12	0	1
	Recommended	24	24	24 ²	12	0	1
US500-800 ³	Minimum	24 ¹	12	24	4	14	1
	Recommended	24	24	30	24	18	1

Notes:

¹ 6" if surface is removable allowing 24" clearance (i.e. closet installation). See Ventilation Air Opening dimensions in Figure 3-1.

² Clearances can be as low as 12" if the right side has a clearance of 24".

³ For models US500-800, ensure rear of unit is accessible for wiring and flue gas testing.

Figure 3-2(a) Wall Mounting Installations (US400)

- 1 While leaving the upper bracket intact (A), remove the wall mount bracket attached to the bottom-back of the boiler (B). Save the mounting hardware for Step 4.
- 2 Secure the wall mount bracket, removed from the bottom of the boiler in Step 1, to a solid wall using field supplied lag screws (anchors when mounting to a concrete wall) that are adequate to support the weight of the boiler (refer to Table 2-1 Specifications). Ensure the wall mount bracket is mounted level and flush to the wall with mounting holes on the bottom, flange pointed upward and angled away from the wall.
- 3 Mount the boiler to the wall by aligning the upper bracket (A) with the wall mount bracket (B). Slide the upper bracket down over the wall mount bracket until it hooks.
- 4 Once the boiler is resting securely on the upper bracket, secure the bottom bracket to the underside of the boiler using the mounting hardware removed in Step 1; then, anchor the bottom bracket to the wall as shown.

WARNING

Failure to follow instructions may result in fire, serious injury, or death.

CAUTION

This unit requires two people to lift it or damage and injury may result.

1

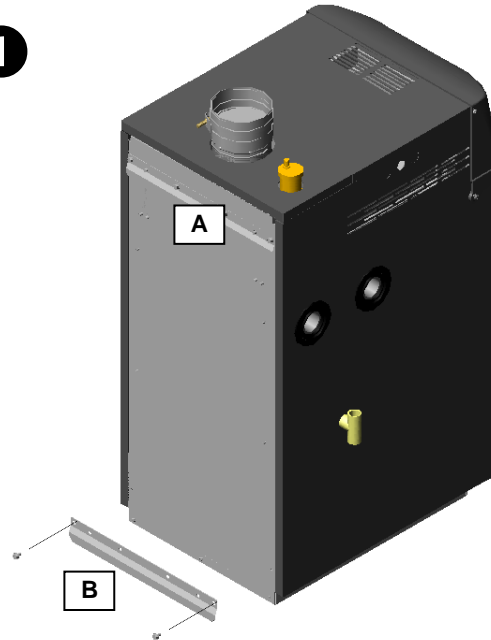

3

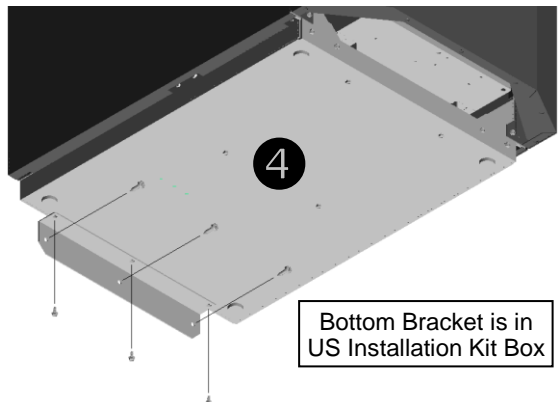
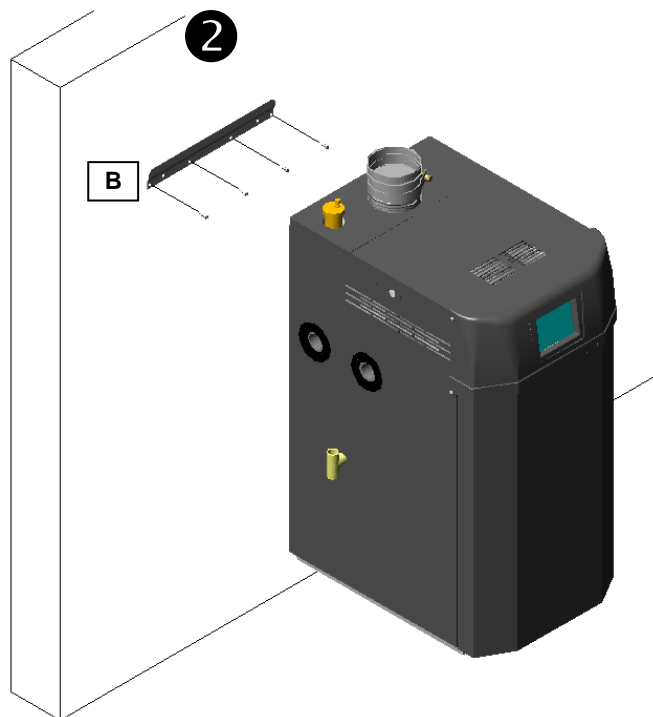
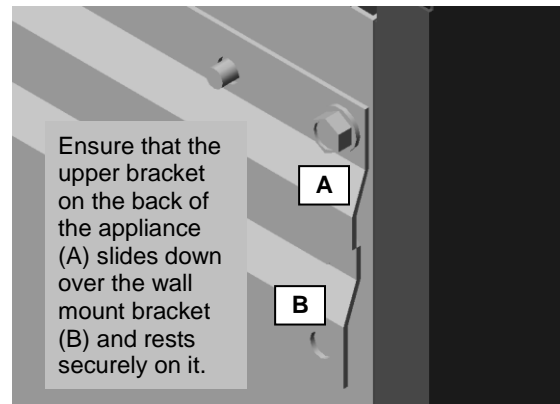

4.0 GENERAL VENTING

The Liberty US is certified as a “Category IV” boiler requiring a “Special Venting System” designed for pressurized venting. The Exhaust Vent must be piped to the outdoors, using the vent materials and rules outlined in this section. Under no conditions may this unit vent gases into a masonry chimney, unless it is vacant, and utilizes the approved venting material and rules described in this section.



Vent and Air-inlet are to be piped separately. The Liberty US cannot share a common vent or air-inlet with multiple appliances. Failure to comply will result in serious injury or death.

Removing an Existing Boiler from Common Venting System



Do not install the Liberty US into a common venting system with any other appliances. Failure to comply with this warning will cause flue gas spillage and leech carbon monoxide emissions into the surrounding air resulting in serious injury or death.



When an existing boiler is removed from a common venting system, the common venting system is likely to be too large for proper venting of the remaining appliances connected to it. Instructions have been provided on how to remove the existing boiler and how to resize the remaining venting system. Failure to follow these instructions may result in property damage, serious injury or death.

At the time of removal of an existing boiler, the following steps shall be followed with each appliance remaining connected to the common venting system placed in operation, while the other appliances remaining connected to the common venting system are not in operation.

Steps to Removing an Existing Boiler

1. Seal any unused openings in the common venting system.
2. Visually inspect the venting system for proper size and horizontal pitch. Verify that there is no blockage, restriction, leakage, corrosion or other deficiencies which could cause an unsafe condition.
3. Insofar as is practical, close fireplace dampers, all building doors and windows and all doors between the space in which the appliances remaining connected to the common venting system are located and other spaces of the building. Turn on clothes dryers and any appliance not connected to the common venting system. Turn on any exhaust fans, such as range hoods and bathroom exhausts, so they will operate at maximum speed. Do not operate a summer exhaust fan.
4. Place in operation the boiler being inspected. Follow the lighting instructions. Adjust thermostat so boiler will operate continuously.
5. Test for spillage at the draft hood relief opening after 5 minutes of main burner operation. Use the flame of a match or candle, or smoke from a cigarette, cigar or pipe.
6. After it has been determined that each appliance remaining connected to the common venting system properly vents when tested as outlined above, return doors, windows, exhaust fans, fireplace dampers and any other gas burning appliance to their previous condition of use.
7. Any improper operation of the common venting system should be corrected so the installation conforms with the National Fuel Gas Code, ANSI Z223.1/NFPA 54 and/or CAN/CSA B149.1, Natural Gas and Propane Installation Code. When resizing any portion of the common venting system, the common venting system should be resized to approach the minimum size as determined using the appropriate tables in Part 11 of the National Fuel Gas Code, ANSI Z223.1/NFPA 54 and/or CAN/CSA B149.1, Natural Gas and Propane Installation Code.

Direct Vent Installation (Mandatory for models US400)

When installed as a Direct Vent boiler the combustion air-inlet must also be piped directly to the outdoors using the methods described in this section and in accordance with the National Fuel Gas Code, ANSI Z223.1 (U.S.) or CSA B149.1 (Canada) and local requirements.

Indoor Combustion Air (Optional for models US500-800)

When the installation uses Indoor Combustion Air (i.e. piping is not directly connecting the boiler air-inlet fitting to the outdoors), provisions for combustion and ventilation air, in accordance with section “Air for Combustion and Ventilation,” of the *National Fuel Gas Code, ANSI Z223.1/NFPA 54* (U.S.), or Clause 8.2, 8.3 or 8.4 of *Natural Gas and Propane Installation Code, CAN/CSA B149.1* (Canada), or applicable provisions of the local building codes, must be adhered to.

NOTICE

The boiler shall be located so as not to interfere with proper circulation of combustion, ventilation, and dilution air.

WARNING

Make up air requirements for the operation of exhaust fans, kitchen ventilation systems, clothes dryers, and fireplaces shall be considered in determining the adequacy of a space to provide combustion air requirements. Failure to ensure adequate make up air to all appliances may result in personal injury or death.

NOTICE

Controller RPM Adjustments – To avoid the potential boiler lockouts due to wind and static pressure differences, the Lightoff and Minimum Modulation RPM Rates must be adjusted as per Figures 4-11 and 4-21 in Appendix A when using indoor combustion air.

Air Filter Kit (P/N ACE84093) – When using indoor combustion air (non-Direct Vent), it is highly recommended to use the optional Air Filter Kit (P/N ACE84093) to limit the amount of dust that enters the combustion system. The Filter Kit can be installed on boiler models US500-800, as illustrated in Figure 4-1 (comprehensive installation instructions are provided with the Filter Kit).

NOTICE

Venting Limitation – When using the Air Filter Kit on models US500-600, the maximum equivalent exhaust vent length is limited to 30 ft. with 4” piping, or 90 ft. with 6” piping; see warning below Table 4-5.

Figure 4-1 Installation of Optional Air Filter Kit (P/N ACE84093)

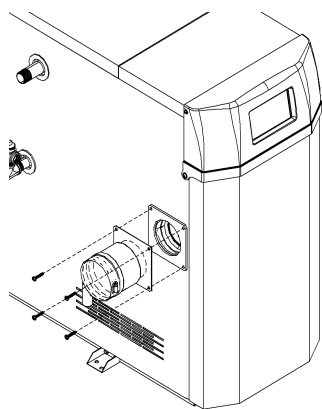

1 Remove factory appliance air-inlet adapter; keep screws from installation of filter kit

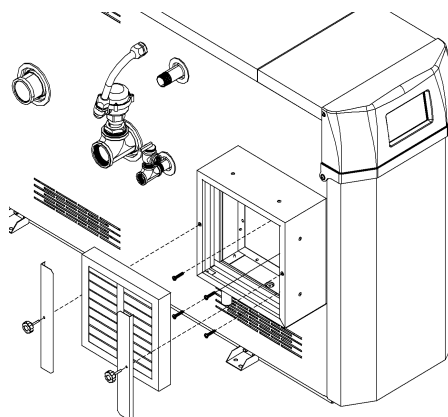

2 Secure filter kit using factory screws removed in step 1. Reuse the factory gasket.

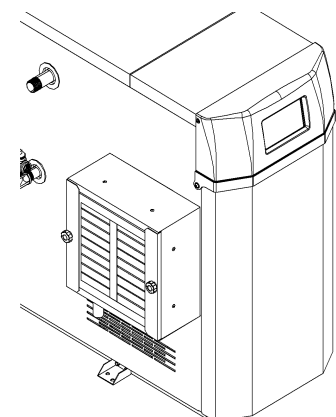

3 Secure the filter in place with the brackets and knurled screws provided in the filter kit.

Combustion Air-inlet Contamination

Be careful not to locate the Air-inlet termination in an area where contaminants can be drawn in and used for combustion. Combustion air containing dust, debris or air-borne contaminants will drastically increase the required maintenance and may cause a corrosive reaction in the Heat Exchanger which could result in premature failure, fire, serious injury, or death. See Table 4-1 for a list of areas to avoid when terminating air-intake piping:

Table 4-1 Corrosive Products and Contaminant Sources

Products to Avoid	Contaminated Sources to Avoid
Antistatic fabric softeners, bleaches, detergents, cleaners	Laundry facilities
Perchloroethylene (PCE), hydrocarbon based cleaners	Dry cleaning facilities
Chemical fertilizer, herbicides/pesticides, dust, methane gas	Farms or areas with livestock and manure
Paint or varnish removers, cements or glues, sawdust	Wood working or furniture refinishing shops
Water chlorination chemicals (chloride, fluoride)	Swimming pools, hot tubs
Solvents, cutting oils, fiberglass, cleaning solvents	Auto body or metal working shops
Refrigerant charge with CFC or HCFC	Refrigerant repair shops
Permanent wave solutions	Beauty shops
Fixer, hydrochloric acid (muriatic acid), bromide, iodine	Photo labs, chemical / plastics processing plants
Cement powder, crack fill dust, cellulose, fiber based insulation	Concrete plant or construction site



Do not store or use gasoline or other flammable vapors and liquids in the vicinity of this or any other appliance. Failure to follow instructions may result in serious injury or death.

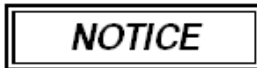

It is **BEST PRACTICE** to pipe the combustion air-inlet directly to the outdoors (Direct Vent installation) to avoid contamination often contained in indoor air.

Flammable Solvents and Plastic Piping

Due to the extremely flammable characteristics of most glues, cements, solvents and primers used in the process of joining plastic vent and air-inlet pipe, explosive solvent vapors must be evacuated from the vent and air-intake prior to start-up. Avoid using excess cement or primer that may lead to pooling inside the pipe assembly. Freshly assembled piping assembly should be allowed to cure for a minimum of 8 hours before applying power to the gas fired appliance. Refer to **Mandatory Pre-commissioning Procedure for Plastic Venting** in this section.



Flammable Cements and Primers – It is the installers' responsibility to familiarize themselves with the hazards associated with explosive solvents and to take all precautions to reduce these risks. Failure to follow these instructions can cause explosions, property damage, injury or death.

Mandatory Pre-commissioning Procedure for Plastic Venting (PVC or CPVC)



Do not apply power to the boiler prior to Step 4 in the Mandatory Pre-commissioning Procedure for Plastic Venting.



Spark Igniter Cable - Maintain a minimum 2" separation between spark igniter circuit and conductors. Failure to follow instructions may result in component failure, injury or death.

- 1) Working with the power turned off to the boiler, completely install the vent and air-inlet system, securely cementing joints together. If possible, allow primers/cements to cure for 8 hours before firing the burner. If curing time is less than 8 hours, proceed with Steps 2 through 6.
- 2) Maintain the boiler gas supply shut-off valve in the off position.
- 3) Disconnect electrical leads to the Hot Surface or Spark Igniter. Ensure the cables are placed in a fashion where they will not arc to ground or other conductor. Refer to warning regarding Spark Igniter Cable.
- 4) Turn power on to the boiler and apply a heat demand.
- 5) Allow for 3 complete trials for ignition, consisting of pre and post purge of the combustion blower, until an ignition lockout occurs. Repeat the process two more times (i.e. 9 complete ignition sequences in total).

6) Turn power off and reconnect the electrical leads to the Igniter.

Near Boiler Vent/Air-inlet Piping

Each Liberty US is equipped with a short piece of approved CPVC vent pipe (see Table 4-2 CPVC Vent Pipe Transition Piece). Insert one end into the boiler flue outlet adapter and cement the other to field venting (see Table 4-4 for approved venting material). The CPVC vent pipe should extend fully into the boiler flue outlet adapter (see Table 4-2). Ensure that the venting system does not apply a load or strain on the boiler flue outlet adapter. The manufacturer recommends using two elbows to create a “swing joint” to reduce potential strain on vent piping and cemented joints; see Figures 4-2 through 4-5.



Gasket Seating - Improper seating can cause leakage and eventual failure of the sealing gasket. Failure to follow these instructions may result in serious injury or death.



PVC Exhaust Venting – **DO NOT** insert PVC pipe directly into the boiler exhaust adapter, as it can deform from the clamping force of the gear clamp. Failure to follow these instructions may result in gasket failure and/or the dislodging of the exhaust pipe from the boiler adapter, resulting in property damage, serious injury or death.

Table 4-2 CPVC Vent Pipe Transition Piece (used when venting with PVC)

Model No.	CPVC Vent Pipe Size	CPVC Transition Vent Pipe Length	Full Insertion Depth
US400-600	4”	Minimum 4” [100 mm]	1-7/8” [48 mm]
US700-800	6”	Minimum 6” [152 mm]	2-1/2” [63 mm]



Polypropylene or Stainless Steel Venting – When using Polypropylene or Stainless Steel piping, the appropriate boiler adapters must be used to transition the boiler vent connections to accept the respective Polypropylene or Stainless Steel venting. See Table 4-3 for a list of approved adapters. Failure to use the correct adapter will result in flue gas leakage resulting in property damage, serious injury or death.

Table 4-3 Boiler Adapters for Polypropylene and Stainless Steel Venting

Model No.	Vent Material	Venting Brand	Adapter Part No. ^{1,2}
US400-600	Polypropylene	DuraVent – PolyPro	300151
		Centrotherm - InnoFlue	ISAA0404
	Stainless Steel	DuraVent – FasNSeal	303631
US700-800	Polypropylene	DuraVent – PolyPro	810004281
		Centrotherm - InnoFlue	ISAA0606
	Stainless Steel	DuraVent – FasNSeal	810005231

Notes:

¹ Listed boiler adapters are only approved for use with the respective venting brand; i.e. a PolyPro boiler adapter shall not be used with InnoFlue venting.

² PolyPro and FasNSeal boiler adapters are available from DuraVent (1-800-835-4429 or www.duravent.com); InnoFlue boiler adapters are available from Centrotherm Eco Systems (1-877-434-3432 or www.centrotherm.us.com).



Exhaust venting must be supported to reduce strain on piping joints. Failure to follow these instructions may result in result in damage, serious injury or death.

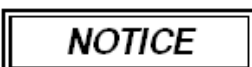

In Canada, the first **3 ft (915 mm)** of vent piping must be readily accessible for inspection.

Figure 4-3(a) Near Boiler Venting (CPVC)

Models US400

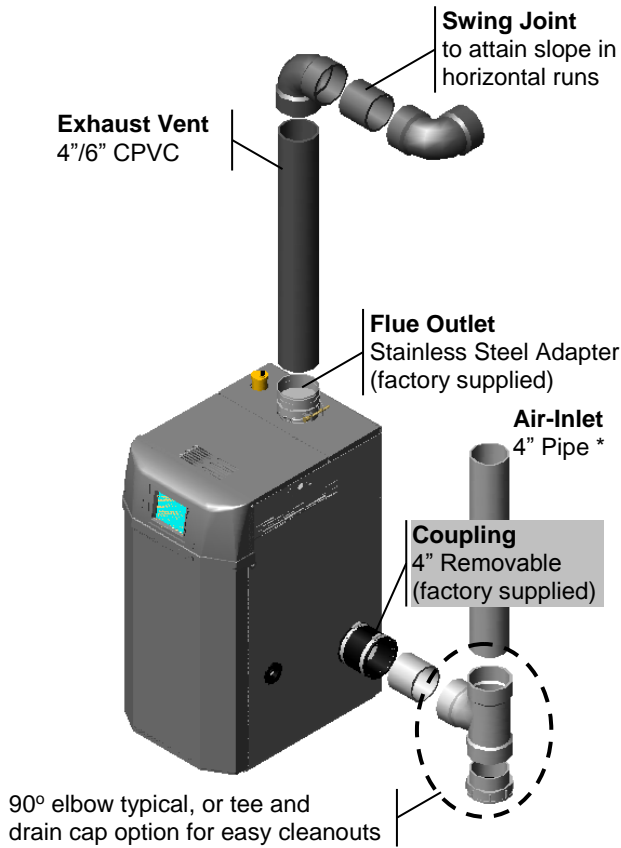
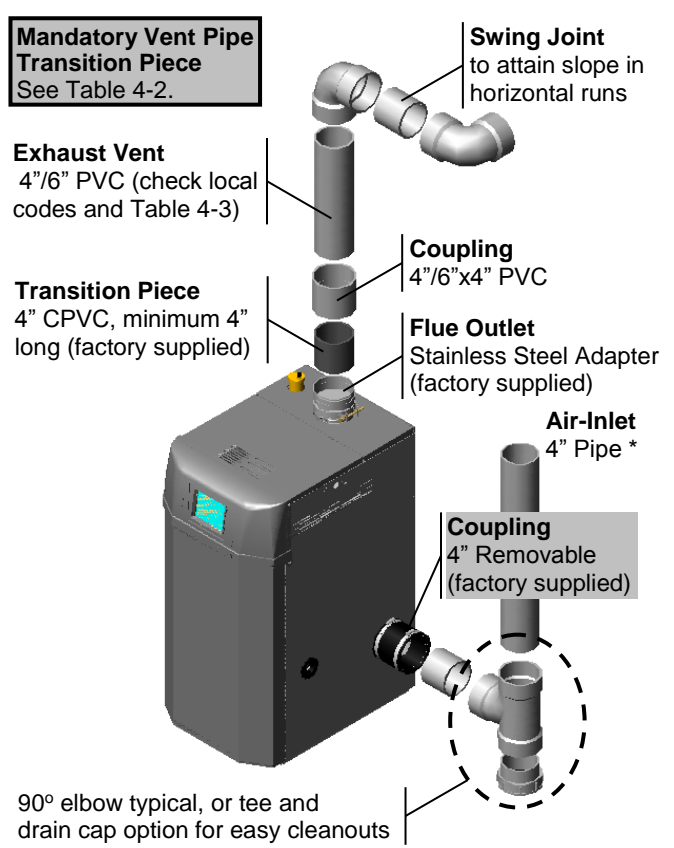

Figure 4-3(b) Near Boiler Venting (PVC)

Models US400



* **Air-Inlet** - check with applicable local codes for acceptable pipe material.

Figure 4-4(a) Near Boiler Venting (CPVC/PVC)
Models US500-600

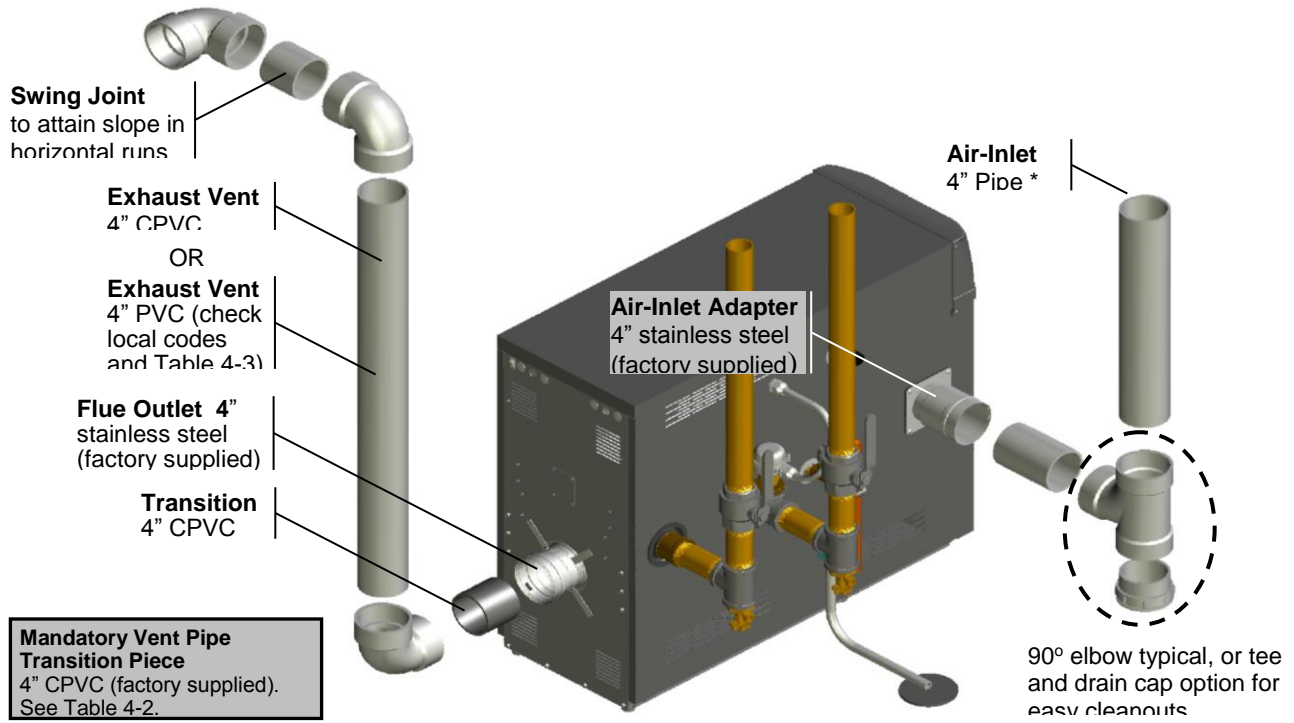

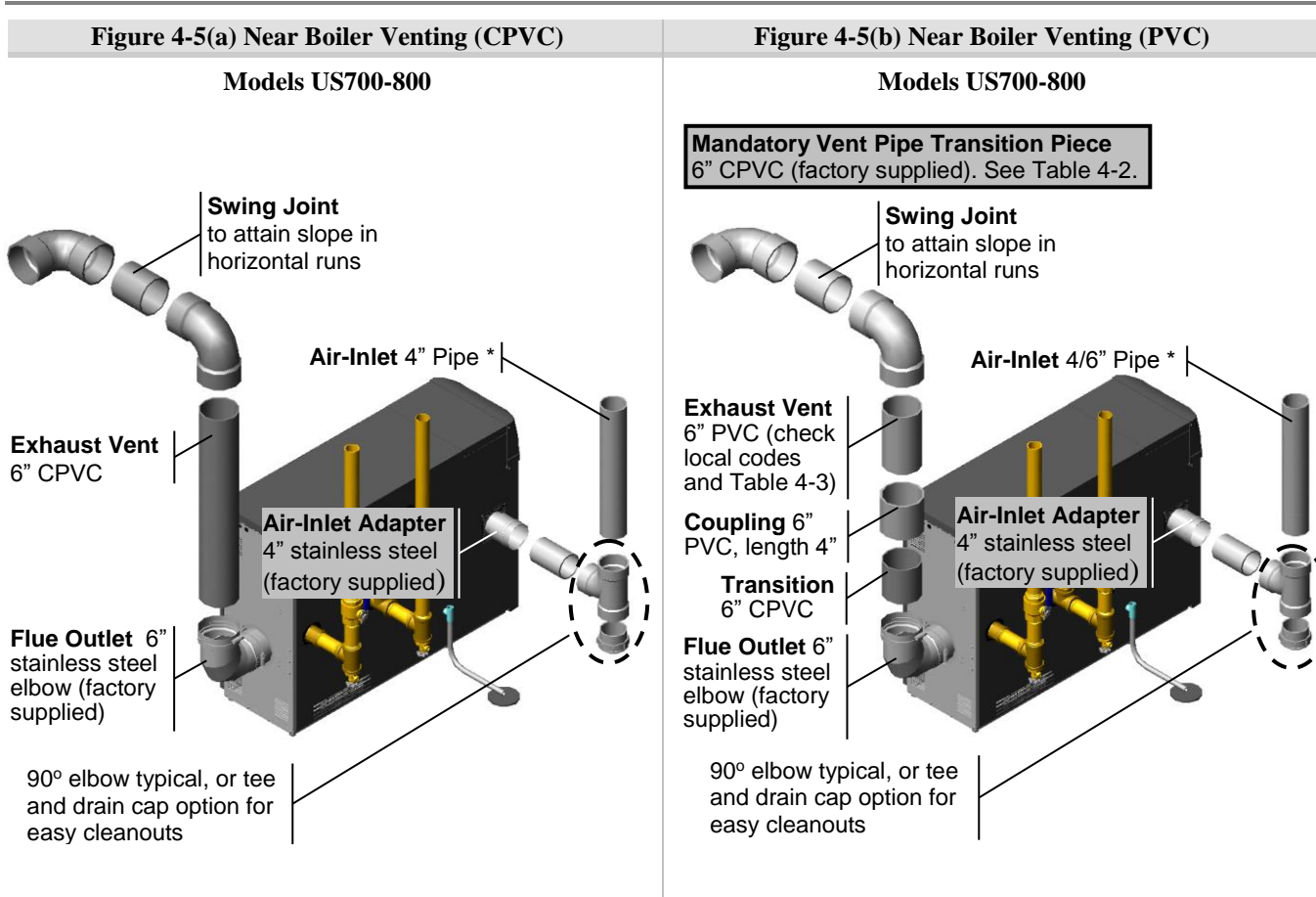

* Air-Inlet - check with applicable local codes for acceptable pipe material.

Vent/Air-inlet Pipe Material

Table 4-4 Acceptable Vent and Air-inlet Pipe Material

Items ¹	Materials ^{2, 3}	Installation Standards		WARNING
		United States	Canada ⁴	
Vent Piping and Fittings	PVC - DWV	ANSI/ASTM D2265	All venting material in Canada must be ULC S636 approved . See Note 4 below for appropriate temperature applications.	All Vent and Air-inlet materials installed on gas fired appliances in CAN/US must meet the Standards listed in Table 4-4. Failure to comply could result in fire, serious injury or death.
	PVC Schedule 40	ANSI/ASTM D1785		
	CPVC Schedule 40	ANSI/ASTM F441		
	AL29-4C	UL-1738		
	Polypropylene (PP)	-		
Pipe Cement	PVC	ANSI/ASTM D2564		
	CPVC	ANSI/ASTM F493		
Primers	PVC / CPVC	ANSI/ASTM F656		

Notes:
¹ Refer to Table 4-5 for Allowable Vent and Air-inlet Pipe Sizes and Lengths.
² PVC venting (exhaust and air-intake) is not permitted within the Closet/alcove of a Closet/alcove installation.
³ The Air-Intake does not require high temperature pipe material. Check applicable local codes for acceptable materials.
⁴ ULC S636 PVC is approved for flue gas temperatures up to 149°F (65°C) and must only be used for low temperature applications. High temperature applications requiring boiler supply water temperatures greater than 140°F (60°C) must use ULC S636 CPVC, PP or AL29-4C.



The use of cellular core PVC (ASTM F891), cellular core CPVC, or Radel® (polyphenolsulfone) in the exhaust venting system is prohibited. Failure to follow these instructions may result in property damage, personal injury or death.



Covering non-metallic vent pipe and fittings with thermal insulation is prohibited. Failure to follow these instructions may result in property damage, personal injury or death.

Vent and Air-inlet Pipe Length Determination

Use Table 4-5 to determine the maximum pipe length that can be used. The table calculates sweep, 90° elbows, and 45° elbows at 5 equivalent feet each.

NOTICE The length of one vent pipe (air-inlet or exhaust) may not exceed the length of the other vent pipe by more than 20 equivalent feet.

Table 4-5 Allowable Vent and Air-Intake Pipe Size and Lengths

Model	Pipe Size	Gas	Length ft.	Number of Elbows (90's or 45's) and Equivalent Feet								
				1	2	3	4	5	6	7	8	9
US400	4" or 6"	NG & LP	100	95	90	85	80	75	70	65	60	55
US500	4" or 6" ³	NG & LP	100	95	90	85	80	75	70	65	60	55
US600	4" or 6" ³	NG ²	100	95	90	85	80	75	70	65	60	55
US700-800	6" ¹	NG ²	100	95	90	85	80	75	70	65	60	55

Notes:

- ¹ Only 6" exhaust vent is permissible for models US700-800. Air-inlet pipe can be 4" or 6" (6" is highly recommended).
- ² Models US600-800 operate with Natural Gas only.
- ³ Models US500-600 are limited to 30 ft. of 4" or 90 ft. of 6" exhaust venting when using the Air Filter Kit (P/N ACE84093).

WARNING **Air Filter Kit venting restrictions** - Models US500-600 are limited to 30 equivalent feet of 4" (or 90 equivalent feet of 6") exhaust vent when using the optional Air Filter Kit. When transitioning from 4" to 6", the 4" venting used must be counted 3 times to convert to an equivalent length in 6".

Example: An application uses one 90° elbow and 5 feet of 4" venting before converting to 6"; therefore, the 4" venting has an equivalent length of 30' [(5' + 5') x 3] of 6" venting; thus allowing an additional 60' equivalent of 6" venting (Note: Example is only true with US500-600 models using the optional Indoor Combustion Air Kit).

Termination Options – Direct Vent Installation

The venting system of the Liberty US may be terminated using field supplied piping to construct a “Two-Pipe” termination, see Figures 4-6(b), 4-7(a), 4-7(b) and 4-8(a); alternatively the venting may be terminated using a factory kit selected from Table 4-6.

Kits certified with the Liberty US are listed in Table 4-6 and available from IPEX, DuraVent, Centrotherm and/or ACE. For more information on System 636 Vent Kits or wholesaler locations contact IPEX directly **USA:** 1-800-463-9572 or www.IPEXamerica.com | **CAN:** 1-866-473-9462 or www.ipexinc.com. For more information on PolyPro Vent Kits or wholesaler locations contact DuraVent directly 1-800-835-4429 or www.duravent.com. For more information on InnoFlue Vent Kits or wholesaler locations contact Centrotherm directly at 1-877-434-3432 or www.centrotherm.us.com.

Table 4-6 Optional Vent Termination Kits

Description	Vent Size	Supplier P/N	Figure	Vent Material Compatibility	Vent Option	
					Roof	Wall
IPEX Low Profile (Flush Mount) ⁷	3”	196985 (P/N ACE84357)	4-9	PVC/CPVC ⁷	✗	✓
	4”	196986 (P/N ACE84358)				
IPEX Concentric (Wall/Roof) ^{5,6,7,8}	3”	196116 (P/N ACE82666)	4-9(b), 4-10(b)	PVC/CPVC ⁷	✓	✓
		197117				
	4”	196021 (P/N ACE84355)				
		197021				
DuraVent - PolyPro Concentric (Wall)	3”	3PPS-HK	4-9(d)	PVC/CPVC/PP	✗	✓
	4”	4PPS-HK				
DuraVent - PolyPro Concentric (Roof)	3”	3PPS-VK	4-10(c)	PVC/CPVC/PP	✓	✗
	4”	4PPS-VK				
Centrotherm – InnoFlue (Flush Mount)	3”	ISLPT0303	4-9	PVC/CPVC/PP	✗	✓
Centrotherm – InnoFlue Concentric (Wall) ⁹	3”	ICWS3513 & ICTC0335	4-9(d)	PVC/CPVC/PP	✗	✓
		ICWT352 & ICTC0335				
	4”	ICWS4639 & ICTC0446				
Centrotherm – InnoFlue Concentric (Roof) ⁹	3”	ICRT3539 & ICTC0335	4-10(c)	PVC/CPVC/PP	✓	✗
	4”	ICRT4679 & ICTC0446				

Notes:

- ¹ Instructions included with termination kits contain detailed assembly and installation instructions.
- ² All factory termination kits are ULC S636 approved.
- ³ Clearance requirements in this manual supersede those of the instructions included with the vent terminal.
- ⁴ Piping **MUST** be secured to the vent terminal during installation.
- ⁵ IPEX Concentric Terminal **MUST** be cemented together and to the vent pipes during installation.
- ⁶ Vent Screens provided with boiler may be used with the IPEX Concentric Vent Kits; otherwise use IPEX vent screens (3 in. vent screen P/N ACE196051 – each sold separately).
- ⁷ IPEX Low Profile and Concentric kits (excluding P/N ACE197009) are constructed out of ULC S636 approved **PVC**; check with your local authority for the acceptance of PVC as a venting material prior to use.
- ⁸ IPEX Concentric kits can be shortened to fit the requirements of the installation; see instructions included with the kit for more details.
- ⁹ Centrotherm Concentric termination kits must use the applicable “Twin pipe to concentric adapter,” part number ICTC0335 or ICTC0446.



Models US400-800 are not approved for use with any of the 3” vent termination kits; only 4” vent termination kits, listed in Table 4-6, are acceptable.



PVC In Canada - Authorities in some jurisdictions may not allow the use of any PVC venting materials with condensing boilers; check with the local safety inspector to verify compliance prior to installing a PVC Concentric Vent Kit with a Liberty US.

IMPORTANT

Sidewall Termination - Due to potential moisture loading (build-up) along the exterior wall, sidewall venting may not be the preferred venting option. Refer to Figures 4-8 and 4-10 for roof top venting options.

Sidewall Termination Examples – Direct Vent Installation

Figure 4-7(a) Two-Pipe Sidewall Termination
(US800 Illustrated)

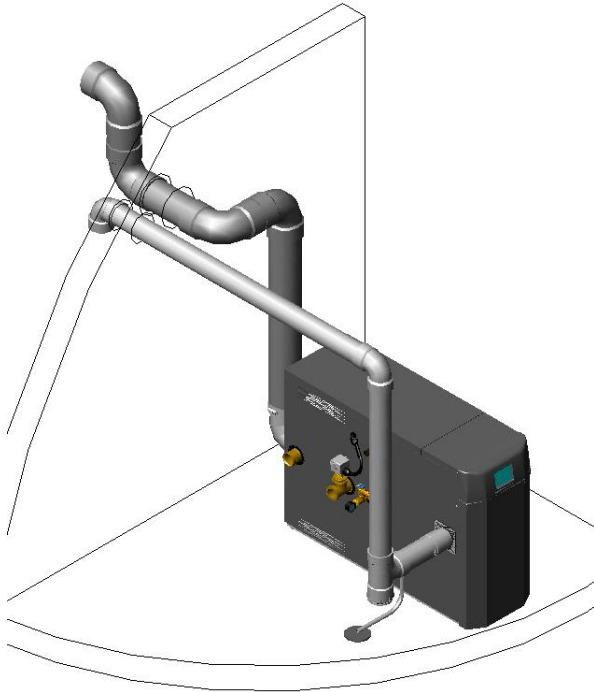
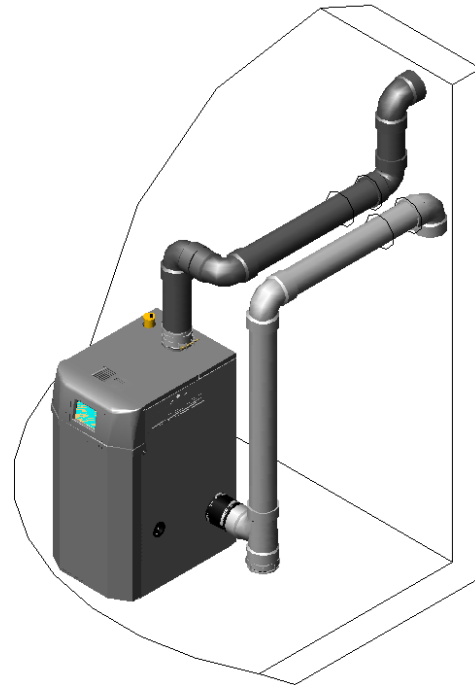
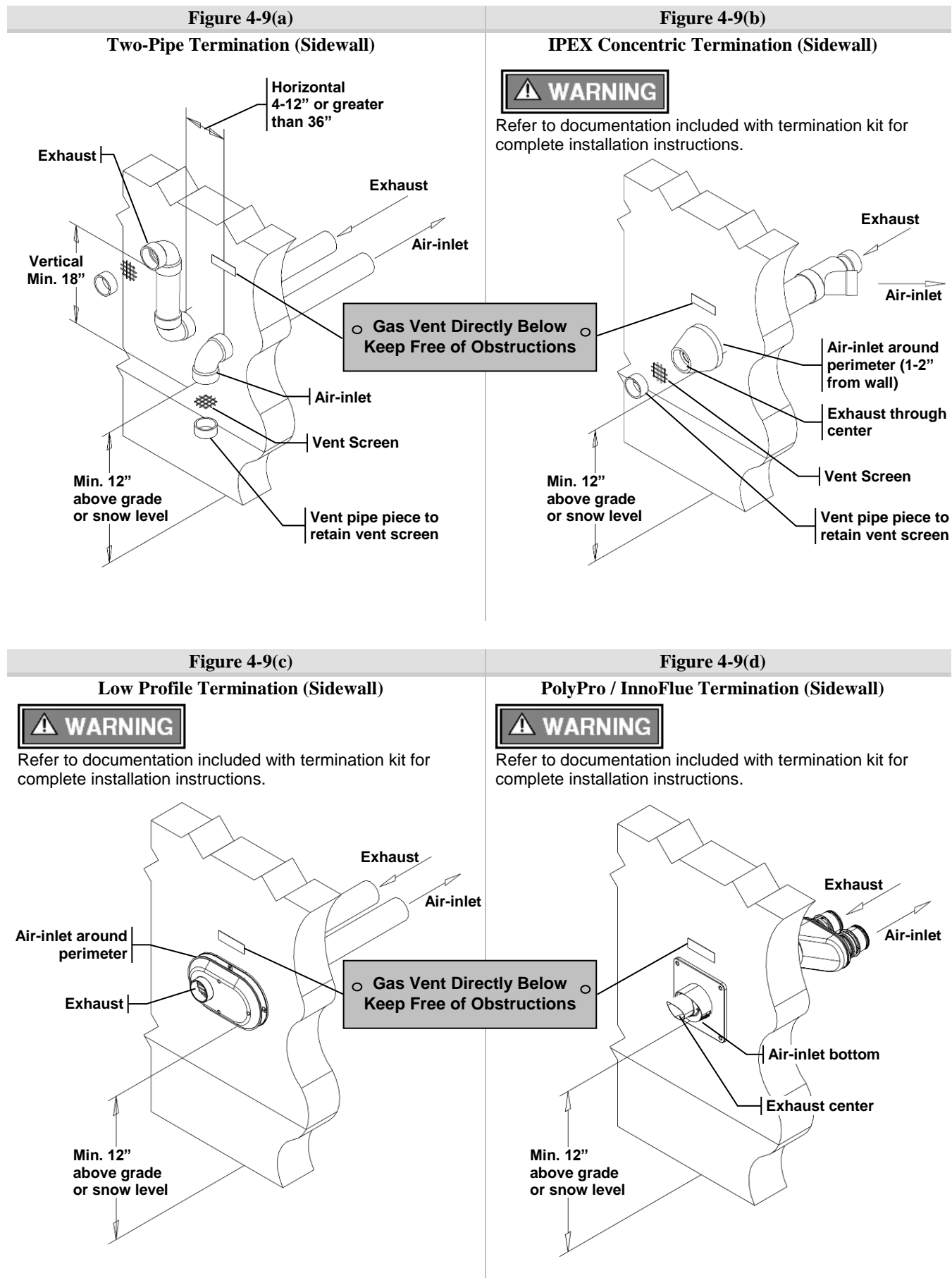

Figure 4-7(b) Two-Pipe Sidewall Termination
(US400 Illustrated)

**WARNING**

Extra precaution must be taken to adequately support the weight of the Vent/Air-inlet piping in applications using roof-top terminations. Failure to follow these instructions may result in venting or boiler component failure resulting in flue gas spillage leading to property damage, serious injury or death.

Sidewall Termination Details – Direct Vent Installation



Roof Termination Details – Direct Vent Installation

Figure 4-10(a)

Two-Pipe Termination (Roof)

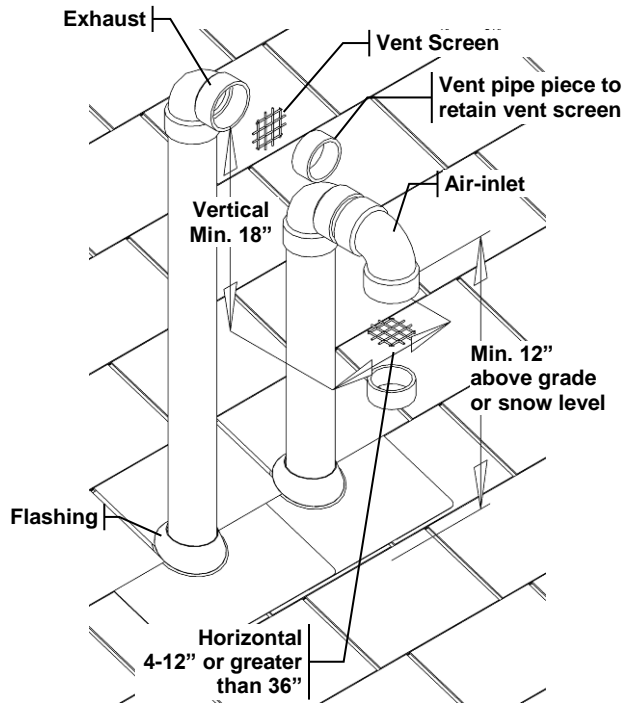

Figure 4-10(b)

IPEX Concentric Termination (Roof)

WARNING

Refer to documentation included with termination kit for complete installation instructions.

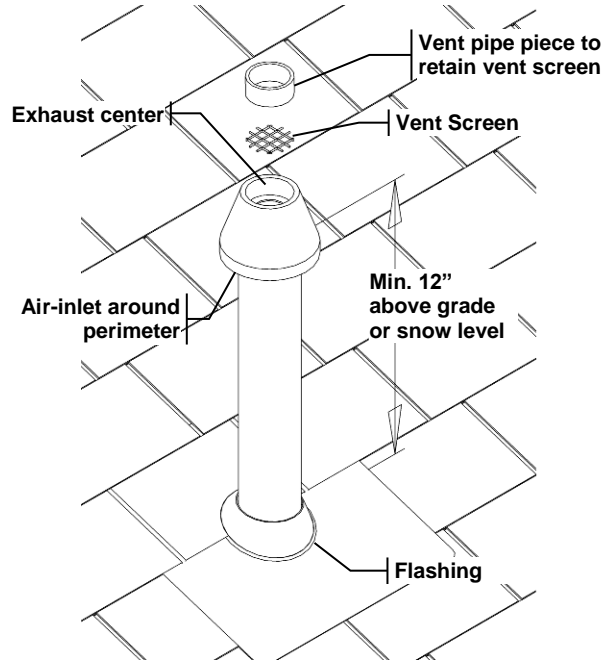

Figure 4-10(c)

PolyPro / InnoFlue Termination (Roof)

WARNING

Refer to documentation included with termination kit for complete installation instructions.

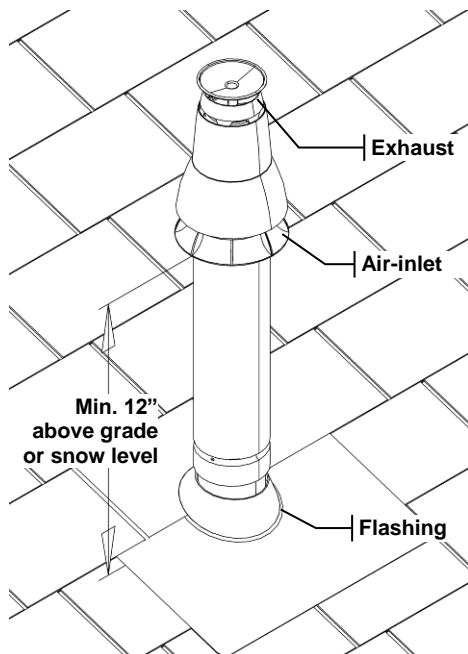
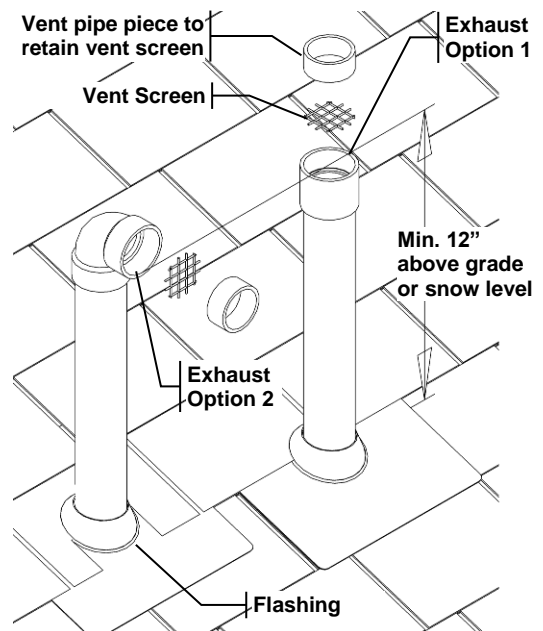

Figure 4-10(d)

Exhaust only Termination (Roof)

WARNING

Figure illustrates two options for exhaust termination only; neither vent pipe illustrated is for combustion air-inlet.



Venting Rules and Guidelines

1. **Prevailing Winds:** Ensure the vent is located where it will not be exposed to normal prevailing winds.
2. **Combustion Air-inlet Contamination:** Air for combustion must be drawn from an area free of dust and contaminants. Combustion air containing chemicals such as chloride, fluoride, bromine or iodine or dust and debris will cause corrosion damage of the heat exchanger voiding your ACE warranty. Refer to Table 4-1 for a list of corrosive products and contaminants sources to avoid.
3. **Vertical Separation:** The exhaust must be a minimum of 18 in. above the air inlet, and the air inlet must always be a minimum of 12 in. plus snow allowance above any surface that will support snow. (Two feet plus snow allowance is highly recommended). Consult your weather office for the maximum typical snowfall for your region.
Example: New Brunswick Canada - typical maximum snowfall is 19 in., thus the inlet must be (12”+19”) = 31 in. above grade and exhaust must be (31”+18”) = 49” above grade.
4. **Horizontal Separation:** The horizontal distance between the inlet and exhaust must be a minimum of 4” [102 mm] center to center.
5. **Wall Flashing:** Under normal operating conditions this boiler will produce a plume of white gases, and should be taken into consideration when selecting an adequate location. A 36 in. diameter stainless, plastic, or vinyl shield can be used to flash the exterior of the residence.
6. **Flue Gas Hazard:** Position the vent termination where vapors cannot make accidental contact with people and pets or damage nearby shrubs and plants.
7. **Elbow Extensions:** Elbows on outside of wall must be no more than ½ in. away from the wall.
8. **Vent Sloping:** All indoor exhaust piping must be on a slope back to the boiler a minimum of ¼ in. per linear foot of vent. For applications where excessive condensation is possible ½ in. per linear foot is recommended.
9. **Vent Supports:** Where required Vent and Air-inlet piping shall be secured to the wall for more rigidity. All interior vent pipe shall be supported a minimum of every 36 in..
10. **Roof Exhaust:** In all roof applications the discharge must point away from the pitch of the roof.
11. **Roof Flashing:** Install adequate flashing where the pipe enters the roof, to prevent water leakage.
12. **Rain Cap:** Install and seal a rain cap over existing chimney openings, in vacant chimney applications.
13. **Venting Below Grade:** For installations that exit the wall below grade refer to Figure 4-11.
14. **Vent Screens:** Install factory supplied vent screens on the outside of the last elbow for both the inlet and exhaust vent terminal elbows. Install the screen into the female opening of the elbow, and then cut a small piece of pipe to sandwich the screen into the elbow. NOTE: ensure the small piece of pipe cut, does not extend past the end of the elbow. Two screens are provided in the package. See Figures 4-9 and 4-10.
15. **Condensate Hazard:** Do not locate vent over public walkways, driveways or parking lots. Condensate could drip and freeze resulting in a slip hazard or damage to vehicles and machinery.
16. **Warning Plate:** For Sidewall Venting, install the warning plate “Gas Vent Directly Below”, directly above (within 4 ft. vertically) the location of the air-inlet pipe, so it is visible from at least 8 ft away. See Figure 4-9.
17. **Wall Thickness:** Direct vent terminations are designed to work with any standard wall thickness. Installation guidelines for min/max wall thickness are as follows: Min. = 1 in., Max. = 60 in..
18. **Venting Options:** Due to potential moisture loading (build-up) along the exterior wall, sidewall venting may not be the preferred venting option. Refer to Figures 4-8 and 4-10 for roof top venting options.



WARNING

The vent for this boiler shall not terminate over public walkways; or near soffit vents or crawl space vents or other area where condensate of vapor could create a nuisance or hazard or cause property damage; or where condensate or vapor could cause damage or could be detrimental to the operation of regulators, relief valves, or other equipment.

Figure 4-11 Venting Below Grade

For installations that exit the wall below grade:

1. Excavate site to a point below where the pipes are to exit as shown.
2. Ensure the wall is fully sealed where the pipes penetrate.
3. The Vent/Air-inlet piping MUST be secured to the side of the building above grade, as shown, to provide rigidity.
4. Optional mounting bracket P/N. ACE82075 for securing the exhaust pipes (only applicable for 3 in. PVC/CPVC venting).
5. Ensure that the Vent/Air-inlet clearances are maintained, see Section 5.0 for details.

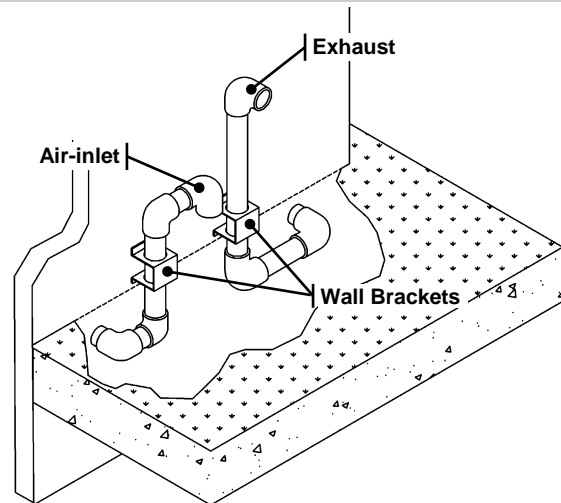

Figure 4-12 Outdoor Venting

Vent piping outside the building is permitted under the following conditions:

1. The maximum length outside the building is 20 ft. Note that outdoor length must be included in the overall vent length calculation.
2. All normal termination clearances are maintained.
3. The pipe is supported every 24 in..
4. The exhaust and inlet are sloped back to the boiler 1/2 in. elevation for every linear foot.

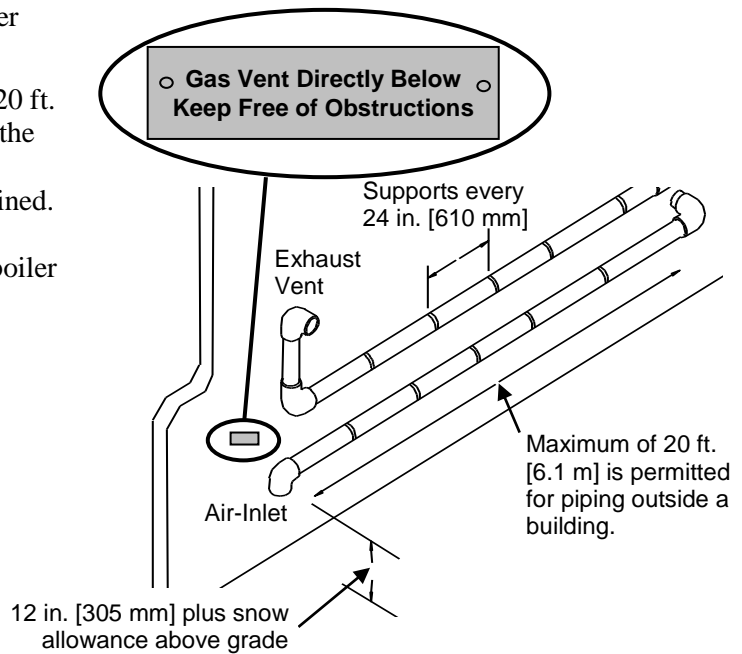
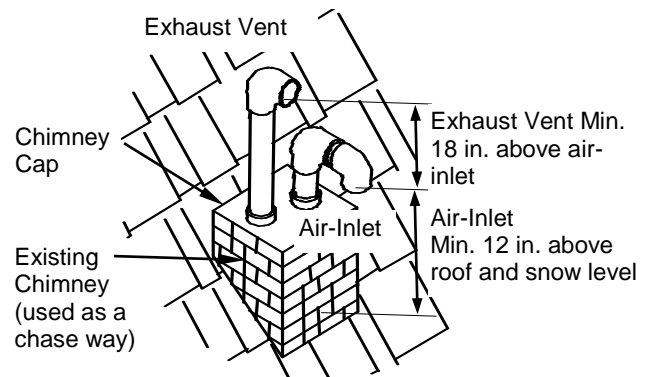

Figure 4-13 Existing Chimney Chase Way

It is permissible to use an existing chimney as a chase way to run the Vent/Air-inlet piping as long as:

1. The chimney is not being used by any other boiler.
2. Flue gases do not enter the vacant chimney.
3. Only Liberty US certified venting materials are used, see Table 4-4.
4. Vent lengths are within the maximums specified.
5. The top of the chimney is capped and the Vent/Air-inlet pipes are flashed to prevent leakage into the vacant chimney.



Under no circumstances may an existing chimney or chase-way be used to vent or provide combustion intake air to a Liberty US. Failure to follow these instructions will result in fire, property damage, serious injury or death.

5.0 VENT AND AIR-INTAKE TERMINATION CLEARANCES

WARNING The quick reference table below is to be read in conjunction with the numbered notes as indicated, Figures 5-1 through 5-6, and the Venting Rules and Guidelines in Section 4.0. The instructions detailed in this section are a combination of Liberty US specific and National Gas Code restrictions. Compliance alone doesn't insure a satisfactory installation as good common sense must also be applied. Failure to follow these instructions may result in fire, property damage, serious injury or death.

Table 5-1 Termination Clearances Quick Reference Table

Clearances to Air-Inlet Termination	Canada ¹		USA ²	
	Min. Distance		Min. Distance	
A Above grade/roofline and snow level ⁸	12 in.	305 mm	12 in.	305 mm
B Above roof line - Concentric Vent ^{6, 11, 13}	24 in.	610 mm	24 in.	610 mm
C To exhaust vent from any other boiler	36 in.	915 mm	12 in.	305 mm
Clearances to Exhaust Vent Termination	Min. Distance		Min. Distance	
A Above grade/roofline and snow level ⁸	12 in.	305 mm	12 in.	305 mm
D Minimum vertical separation above air inlet ⁹	18 in.	457 mm	18 in.	457 mm
E Minimum horizontal separation from air inlet ³	4 in.	102 mm	4 in.	102 mm
F Window or door that may be opened, or other building opening	36 in.	915 mm	12 in.	305 mm
G To combustion air inlet of any other appliance	36 in.	915 mm	12 in.	305 mm
H Non-mechanical air supply inlet to building	36 in.	915 mm	12 in.	305 mm
I Mechanical air supply inlet to building ⁴	6 ft.	1.83 m	3 ft.	915 mm
J Soffit, overhang, eave or parapet	24 in.	610 mm	24 in.	610 mm
K Soffit vent or vent opening in an overhang, eave or parapet	6 ft.	1.83 m	6 ft.	1.83 m
L Outside corner ¹⁰	-	-	-	-
M Inside corner of an L-shaped structure (including walls and fences)	36 in.	915 mm	36 in.	915 mm
N Service regulator / vent outlet	36 in.	915 mm	36 in.	915 mm
P Each side of center line above or below meter / regulator assembly ⁵	36 in.	915 mm	36 in.	915 mm
Q Above a paved sidewalk, driveway, or parking lot on public property if adjacent ¹²	7 ft.	2.13 m	7 ft.	2.13 m
R Above a public walkway	x	x	x	x
S Above a sidewalk or paved driveway that is located between two single family dwellings and services both dwellings	x	x	x	x
T Under a concrete veranda, porch, deck, or balcony ⁷	24 in.	610 mm	24 in.	610 mm
U Above, under or near exterior stairs	x	x	x	x
V Into a canopy or carport	x	x	x	x

Notes:

- 1 - Canadian installations must comply with the current CSA B149.1 Natural Gas and Propane Installation Code and local building codes.
 - 2 - US installations must comply with current ANSI Z223.1/ NFPA 54 National Fuel Gas Code and local building codes.
 - 3 - Horizontal separation center-to-center (c.c.) 4'-12" (102-305 mm).
 - 4 - For US installations, an exhaust vent must be 3 ft above a mechanical air supply inlet if within 10 ft. [3 m] horizontally.
 - 5 - Horizontal clearance must be observed up to a height of 15 ft. [4.6 m] above/below the meter, regulator, or relief devices.
 - 6 - Concentric Vent must protrude from the roof precisely 24" [610 mm] measuring from the terminal end-cap vanes.
 - 7 - Permitted if veranda, porch, deck, or balcony is made of concrete and a minimum of two sides are fully open beneath.
 - 8 - 24" is the recommended snow level allowance above grade/roofline or any surface that will support snow, debris, or ice (i.e. for roof venting clearances - roofline and snow level). If living in a snowfall region, consult your local weather office for the maximum typical snowfall for your area.
 - 9 - Note that the vent must maintain a minimum vertical distance above the air-inlet. Example: Vent height = 18" (457 mm) above air inlet + 12" (305 mm) for air inlet above grade/roof line and snow level = 30" (762 mm) above grade and snow level.
 - 10 - Clearances to an outside corner to be in accordance with local installation codes.
 - 11 - In Canada, concentric vent materials are subject to approval by local inspectors. See Termination Kits in Section 4.0.
 - 12 - Above public walkways, driveways or parking lots if adjacent to it and condensate cannot drip, freeze, or create a hazard.
 - 13 - Contact the manufacturer for special exemptions relating to multiple boiler installations using concentric vents.
- X** - Not permitted by National gas code(s) and/or recommended by boiler manufacturer.

Figure 5-1 Termination Clearances Quick Reference Diagram

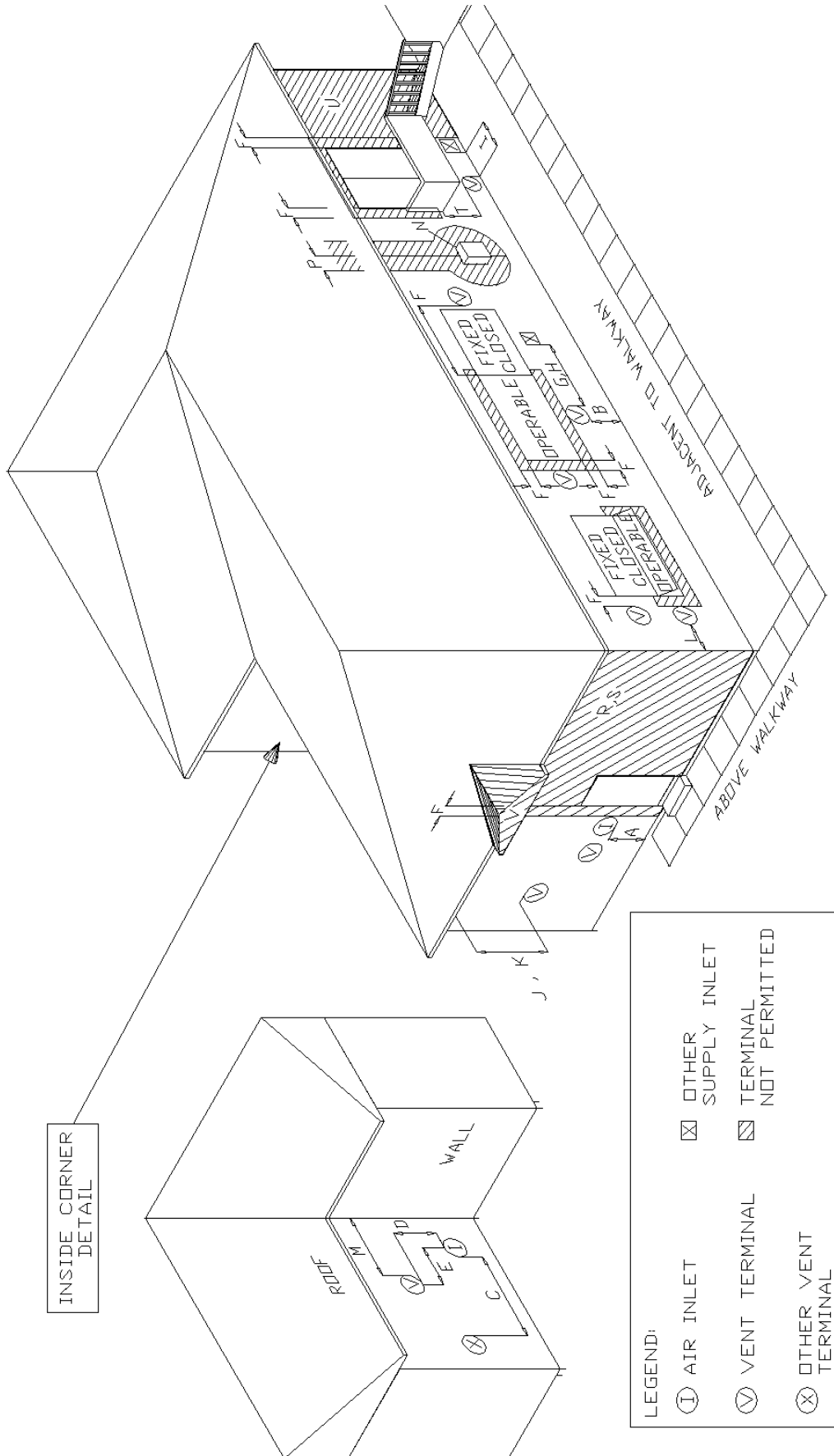
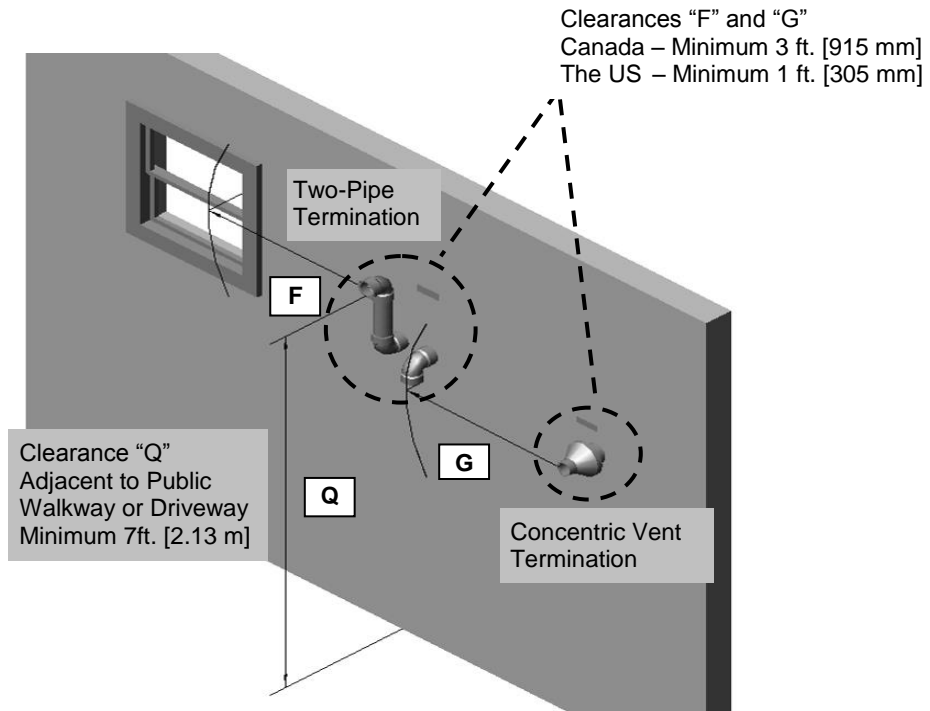

Figure 5-2 Sidewall Termination Clearances (See Table 5-1)



G – Letter represents a specific Termination Position. Refer to Table 5-1 for corresponding termination clearances.

6.0 CONDENSATE DRAIN

This unit produces liquid condensate in the heat exchanger and venting system as a product of combustion. Steps must be taken to ensure that condensate does not collect in the venting system; therefore, all exhaust piping must slope back to the boiler a minimum 1/4" per linear foot of vent. Condensate must be drained from the unit into a household drain.

NOTICE

Check with your municipality, or local gas company to determine if the disposal of combustion condensate is permitted in your area (e.g. in the **State of Massachusetts** the condensate must be neutralized prior to entering a drain).

The following are important notes that must be taken into consideration when constructing the condensate drain system (See Figure 6-1 for further details):

- **DO NOT** install condensate lines outside. A frozen or blocked drain will cause the condensate to fill the combustion chamber. This will result in a no heat condition, as the unit will shut down, and damage to the flame sensor, and components can occur.
- **NEVER** use copper, steel, or galvanized piping in the construction of the condensate disposal system as condensate is very corrosive and will corrode most metallic drains and sewer pipes.
- When a condensate pump is used or required, select a pump that is designed for residential furnaces.

WARNING

If the combustion chamber has been flooded due to the condensate drain backing up, or for any other reason, the combustion chamber door must be removed and the inside of the boiler must be inspected for component damage, e.g. the internal insulation at the front and back of the chamber. Failure to follow these instructions may result in fire, property damage, serious injury or death.

**Figure 6-1 All Models
Condensate Drain Piping**

Drain Vent

Do not block or install piping into the top branch of the condensate drain tee.

Drain Pipe

Connection to the bottom of the condensate drain tee must be made using 1/2" Schedule 40 PVC pipe. Secure using appropriate PVC cement. All piping must be below the level where the condensate leaves the boiler.

Floor Drain

Check with your local authorities regarding disposal of condensate (regulation may require the use of a neutralizer).

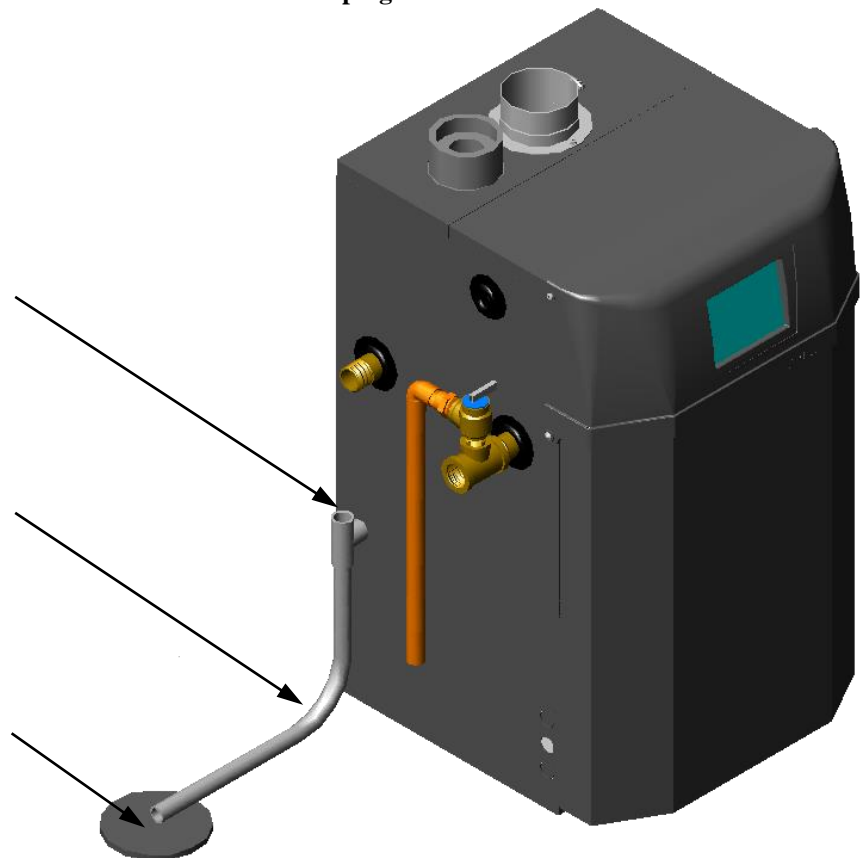

7.0 INSTALLING GAS PIPING



WARNING

The Liberty US is factory equipped to operate with Natural Gas, the installation of a conversion kit is required prior to operating with Propane Gas. The Natural to LP Conversion Kit (see Table 7-1) must be installed prior to installing the gas piping to the boiler. Failure to properly convert the unit to operate with Propane may result in property damage, serious injury or death.



WARNING

Liquefied Petroleum (LP) propane gas is heavier than air. Do not install the boiler in a pit or similar location that will permit heavier than air gas to collect. Check with Local Codes as they may require appliances fueled with LP gas to be provided with an approved means of removing unburned gases from the room. Failure to follow these instructions may result in serious injury or death.

Table 7-1 Natural Gas to LP Propane Conversion Kit

Model Number	LP Conversion Kit Number	LP Orifice
US400	83017-1	62 (6.2 mm)
US500	84386-1	No Orifice ¹
Notes:		
¹ No LP orifice is used with model US500, see conversion kit instructions for information on adjusting the throttle screw convert boiler to LP.		
² Models US600-800 cannot be operated with LP – Propane. Use Natural Gas only.		

Installation

Refer to the current **National Fuel Gas Code ANSI Z223.1/NFPA 54** or **CAN/CGA B149.1** installation codes, and local codes for gas piping requirements and sizing. Pipe size running to the unit depends on:

- Length of pipe.
- Number of fittings.
- Type of gas.
- Maximum input requirement of all gas appliances in the residence.

Ensure that:

- The gas line connection to the boiler does not apply any weight to the gas valve. ACE recommends using approved flexible gas piping (if acceptable by local codes) to connect the boiler to the gas supply (See Figure 7-1 for details).
- You plan the installation so that the piping does not interfere with the vent pipe, or the removal of the valve, burner, and serviceable components.
- The boiler shall be installed such that the gas ignition system components are protected from water (dripping, spraying, rain etc.) during installation and servicing.
- The gas piping is large enough for all the appliances in the home. No appreciable drop in line pressure should occur when any unit (or combination of units) lights or runs. Use common gas-line sizing practices.
- Always use a pipe-threading compound that is resistant to propane (LP) gas solvent action. Apply sparingly to all male threads, starting at two threads from the end. Over doping or applying dope to the female end, can result in a blocked gas line.
- **DO NOT TIGHTEN FITTINGS WITHOUT SUPPORTING THE GAS VALVE** as damage to the gas valve or combustion blower can occur.
- Install a manual “Equipment Shut-Off Valve” as shown in Figure 7-1. Valve must be listed by a nationally recognized testing lab.
- The gas line piping can safely be removed from the boiler for servicing, by strategically placing the gas line shutoff and union; see example in Figure 7-1.
- All gas piping, including gas components in the boiler, are checked for leaks using a “Bubble Test”, prior to operating the boiler.



Strain on the gas valve and fittings may result in vibration, premature component failure and leakage and may result in a fire, explosion, property damage, serious injury or death.



Flexible gas piping cannot be used within the boiler cabinet and cannot pass through the cabinet wall, use rigid piping as shown in Figure 7-1. Failure to follow these instructions may result in fire, property damage, serious injury or death.



Do not use an open flame to test for gas leaks. Failure to follow these instructions may result in fire, property damage, serious injury or death .



When performing a pressure test on the gas line piping, be sure the boiler is disconnected or isolated if the test pressure is expected to exceed 1/2 PSI (14" w.c.), as damage to the valve could occur resulting in fire, property damage, serious injury or death.

8.0 LIGHTING THE BOILER

Before Start-up refer to **Mandatory Pre-commissioning Procedure for Plastic Venting** in Section 4.0. Failure to follow these instructions can result in explosions, injury or death.



Prior to turning the gas supply on and lighting the boiler, ensure all aspects of the installation are complete and in conformance with the instructions provided in this manual, including the Vent/Air-Intake, Condensate Drain, and System Water Piping. Failure to precisely follow these instructions will cause a fire or explosion resulting in property damage, serious injury or death.



Do not store or use gasoline or other flammable vapors & liquids in the vicinity of this or any other appliance. Failure to follow instructions could result in explosion causing property damage, serious injury or death.



If you do not follow these instructions exactly, a fire or explosion may result causing property damage, serious injury or death.



Should overheating occur or the gas supply fail to shut off, turn off the manual gas control valve to the boiler. Failure to follow instructions could result in explosion causing property damage, serious injury or death.

FOR YOUR SAFETY, READ BEFORE OPERATING

- A) This boiler does not have a pilot. It is equipped with an ignition device which automatically lights the burner. Do not try to light the burner by hand.
- B) BEFORE OPERATING smell all around the boiler area for gas. Be sure to smell next to the floor because some gas is heavier than air and will settle on the floor.
WHAT TO DO IF YOU SMELL GAS:
 - Do not try to light any boiler.
 - Do not touch any electric switch.
 - Do not use any phone in your building.
 - Immediately call your gas supplier from a neighbor's phone. Follow the gas supplier's instructions.
 - If you cannot reach your gas supplier, call the fire department.
- C) Use only your hand to push in or turn the gas control knob. Never use tools. If the knob will not push in or turn by hand, don't try to repair it, call a qualified service technician. Force or attempted repair may result in a fire or explosion.
- D) Do not use this boiler if any part has been under water. Immediately call a qualified service technician to inspect the boiler and to replace any part of the control system and any gas control which has been under water.

OPERATING INSTRUCTIONS

1. STOP! Read the safety information above very carefully.
2. Set the thermostat to lowest setting. Turn off all electric power to the boiler.
3. This boiler does not have a pilot. It is equipped with an ignition device which automatically lights the burner. Do not try to light the burner by hand.
4. Turn the manual gas valve to the OFF position. Remove front access panel.
5. Wait five (5) minutes to clear out any gas. Then smell for gas, including near the floor. If you smell gas, STOP! Follow "B" in the safety information above. If you don't smell gas, go to the next step.
6. Turn the manual gas valve ON. Wait an additional five (5) minutes smelling for gas.
7. Replace the front access panel.
8. Set thermostat to highest setting. Turn on all electric power to the boiler.
9. Ignition sequence is automatic. Combustion will occur after a brief fan purge.
10. If ignition does not occur, follow the instructions "To Turn Off Gas To Boiler" and call your service technician or gas supplier.

TO TURN OFF GAS TO THE BOILER

1. STOP! Read the safety information above very carefully.
2. Turn off all electric power to the boiler.
3. Turn the manual gas valve to the OFF position.

⚠ WARNING

The initial lighting of the boiler must be performed by a licensed Gas Technician. Failure to follow instructions may result in property damage, serious injury or death.

- Ensure the boiler is wired in accordance with this manual.
- Ensure the gas shut-off valve is turned on, and that the gas system has been fully tested for leaks.
- Ensure the system is completely filled with water, and that ALL the air is purged out.

⚠ DANGER

Allow primers/cements to cure for 8 hours prior to Start-up. If curing time is less than 8 hours, first perform Steps 2 through 6 of **Mandatory Pre-commissioning Procedure for Plastic Venting** in Section 4.0. Failure to follow these instructions can result in explosion, serious injury or death.

Initial Start-Up

1. Turn on power to the Liberty US and turn-up the Thermostat(s). The boiler should run through a purge, and combustion should occur. (The control system has a built in ignition retry, allowing the system to try at least three times, before locking-out.)
2. With the unit operating at full capacity, verify that the gas line pressure is 5.5-10.5 inches w.c. for Natural gas, and 9-13 inches w.c. for Propane (See Section 9.0 for details).
3. Using an appropriate Oxygen or Carbon Dioxide analyzer, take a sample of the flue gas. The sample must fall within the acceptable ranges for Carbon Dioxide, which is 8.8% - 9.8% for Natural gas, and 9.8%-10.8% for propane (See Section 9.0 for details).
4. Perform at least three lights in succession to ensure proper operation.
5. After the three successive lights, unplug the flame probe, and allow the unit to cycle again. Ensure that it tries to light, and locks out on safety reset. Once you have successfully activated the flame safety system, replace the wire on the flame sensor, and reconfirm proper lighting.

⚠ WARNING

If the unit fails to light consistently and smoothly, contact ACE for technical assistance. Never allow the boiler to operate if the ignition or operation of the burner is rough or erratic. Failure to follow these instructions may result in serious injury or death.

⚠ WARNING

The flame probe uses a single electrode located in the burner door at the 6 O'clock position. DO NOT remove the wire from the dual electrode located in the burner door at the 3 O'clock position; this device is used for spark igniting and delivers a high

voltage potential which would result in an **EXTREME ELECTRICAL SHOCK** possibly causing serious injury or death.

Re-lighting Unit

1. Stop and read these instructions very carefully.
2. Set the thermostat to the lowest setting, and then turn off all power to the boiler.
3. This boiler does not have a pilot. It is equipped with an ignition device that automatically lights the burner. Do not try to light the burner by hand.
4. Turn the gas shut-off valve to the off position, and then remove the front cover.
5. Wait five (5) minutes to clear out any gas. Then check for gas, including near the floor. If you smell gas "Stop" and follow "B" above. If you don't detect any gas proceed to the next step.
6. Turn the gas shut-off valve to the on position, wait an addition five (5) minutes and check for gas.
7. Replace the front cover.
8. Set the thermostat to the highest setting, and then turn on all power to the boiler.
9. Ignition sequence is automatic, combustion will occur after a brief fan purge. Ignition will retry 3 times.
10. If ignition does not occur, "Turn off the gas and electricity to the boiler" and contact a professional service technician, or gas supplier.

Turning Off The Boiler

1. Set the thermostat to the lowest setting, and then turn off all power to the boiler.
2. Turn the gas shut-off valve to the off position.

9.0 GAS VALVE AND BURNER SET-UP



The Liberty US gas valve must be set-up by a licensed Gas Technician. Improper set-up may result in incorrect operation, damage to components or property, injury or death.

Gas Line Pressure

The boiler gas valve is equipped with a line pressure test port; see Figures 9-1 through 9-4. Use the following procedure to measure the gas line pressure to the boiler to ensure it falls within the range given in Table 9-1:

1. Turn the supply of gas to the boiler off.
2. Open the bleed screw of the line pressure test port approximately 1-1/2 turns (US400-500 models). This port is directly connected to the gas line feeding the boiler. For US600-800 models, replace 1/8" NPT plug in the inlet flange of the gas valve with a hose barb fitting suitable for manometer tubing used. See Figures 9-1 through 9-5.
3. Force 1/4" ID tubing over the housing of the line pressure test port; install the other end of the tubing to an appropriate line pressure test gauge or manometer. Ensure both ends of the tubing make a tight connection.
4. Open the supply of gas to the boiler and check for gas leaks.
5. Observe the line pressure under static conditions and compare it to Table 9-1. The pressure will be greatest under static conditions.
6. With all other gas appliances in the applications running, operate the burner to the maximum firing rate (see Table 9-2) and compare the observed line pressure with Table 9-1. The pressure will be lowest during the maximum flow of gas.
7. Adjust the gas line pressure to ensure the parameters in Table 9-1 are attained under all conditions. If possible adjust the line pressure to the "Nominal/Desired" value listed in Table 9-1, while the unit is operating at the maximum modulation rate, see Table 9-2.
8. Continue observing the gas line pressure until the completion of the combustion analyses, incase adjustments need to be made.
9. Upon completion of the line pressure testing, return the bleed screw of the Line Pressure Test Port to the closed position. For the US600-800 models, replace the installed hose barb fitting with the factory 1/8" NPT plug; use NG/LP approved thread sealant.

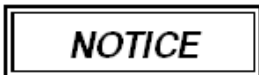

The line pressure is a function of the gas supply and is affected solely by field provided parameters such as line size and regulator settings. Under no circumstances can the boiler gas valve influence or be used to adjust the gas line pressure.



Failure to close the bleed screw of the Line Pressure Test Port will cause a severe leakage of gas, resulting in a fire or explosion causing property damage, serious injury or death.

Table 9-1 Line Pressure and Combustion Parameters

Gas	Line Pressure (inches wc)			CO ₂ (%) ¹		CO (ppm) Max.
	Nominal/Desired	Min.	Max.	Min.	Max.	
Natural	7	4 ²	10.5	8.8	9.8	175
Propane	11	8	13	9.8	10.8	175

Notes:

- ¹ It is permissible to have higher CO₂ values with the burner operating at the minimum modulation rate.
- ² The minimum permissible line pressure when operating with Natural Gas is 5.5 inches wc for model US500.

Table 9-2 Minimum and Maximum Modulation Rates

Modulation Rates (rpm)	US400	US500	US600	US700	US800				
Minimum	1550	1400	1050	1250	1250				
Maximum	7250	6400	4350	4300	5300				



Carbon Monoxide - Never leave the boiler operating if emitting Carbon Monoxide (CO) concentrations in excess of 175ppm. Failure to comply may result in injury or death.



Manifold Pressure - DO NOT adjust or measure the Manifold Pressure of the boiler. Correct manifold pressure is factory set. Field adjustment could result in improper burner operation resulting in fire, explosion, property damage or death.

Figure 9-3 Gas Valve and Venturi Assembly (US400)

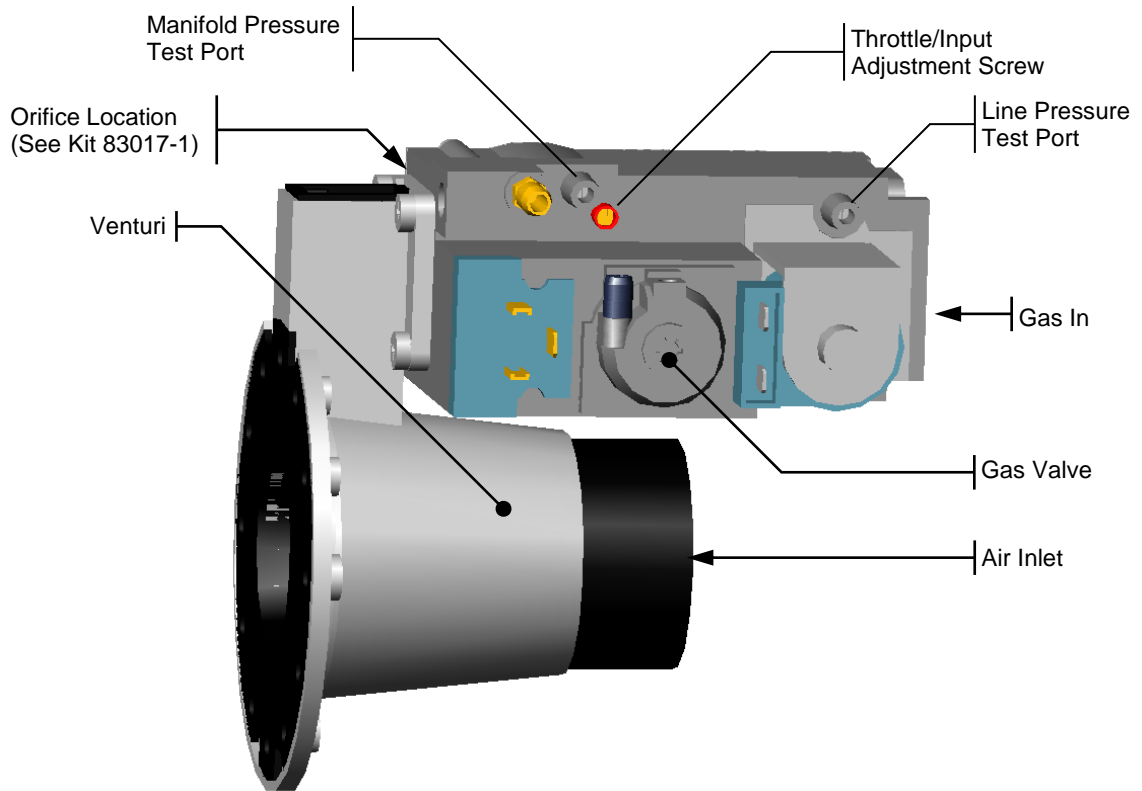

Figure 9-4 Gas Valve and Venturi Assembly (US500)

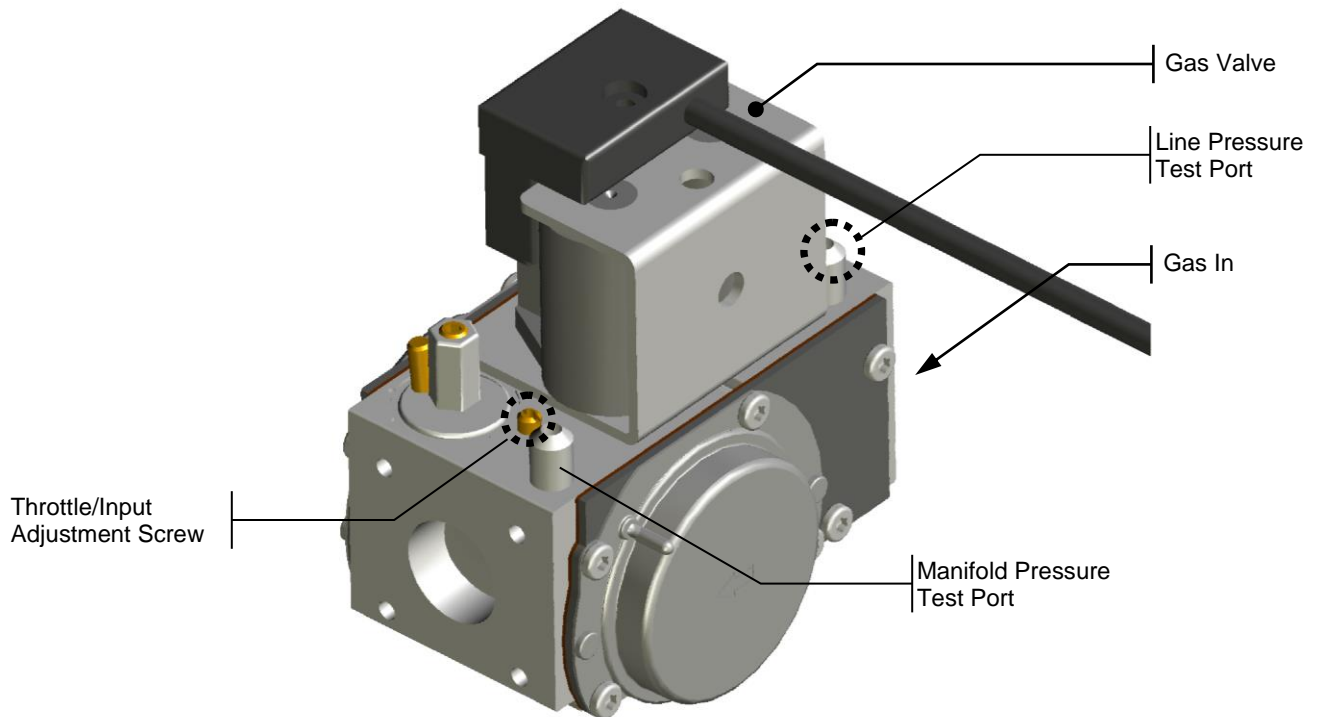
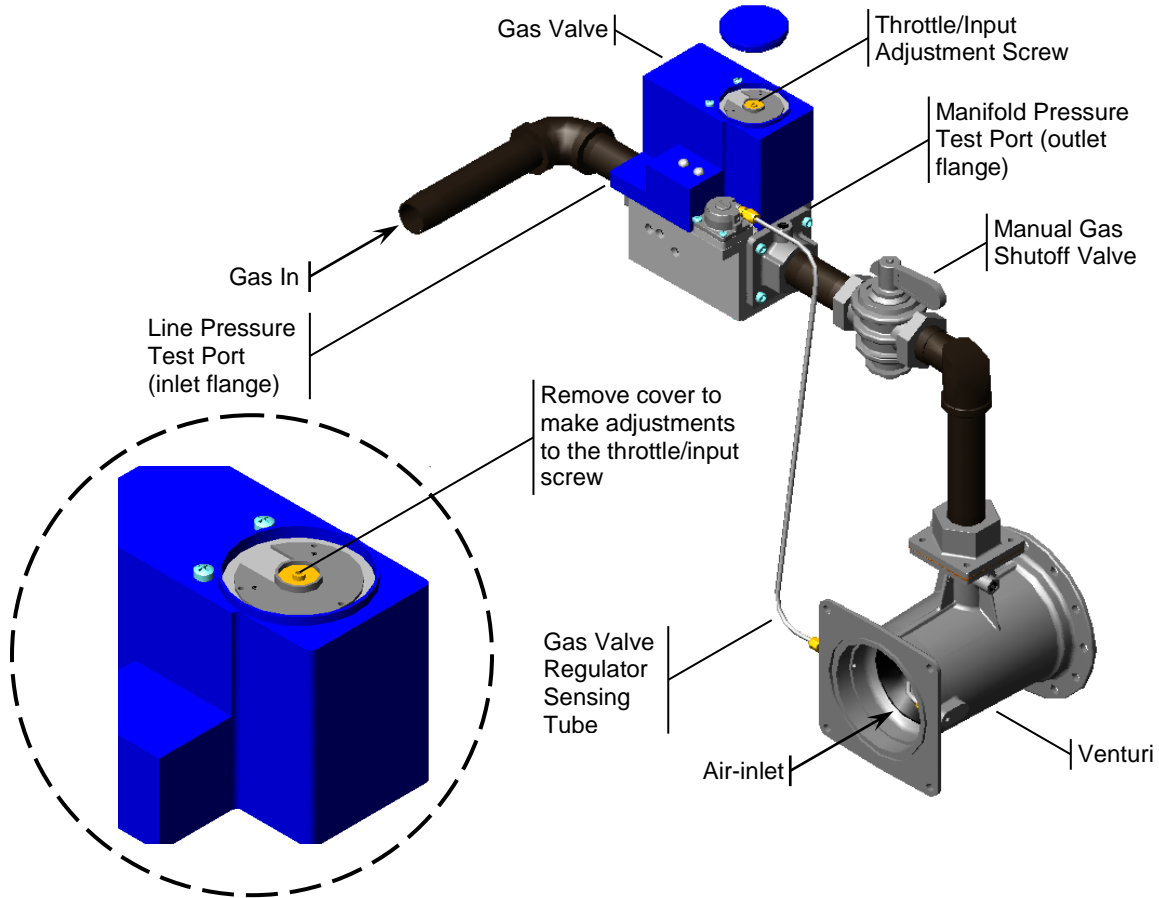

Figure 9-5 Gas Valve and Venturi Assembly (US600-800)



Adjustment

Input Screw Adjustments - The boiler is equipped with a Throttle/Input Adjustment Screw, located on the Gas Valve and Venturi Assembly. The Throttle screw is used to adjust the flow of gas leaving the gas valve, entering the Venturi and hence entering the combustion air stream. By turning the adjustment screw in, clockwise, the flow of gas is reduced and the combustion becomes leaner, thus reducing the concentration of CO₂ in the flue gases. To increase the CO₂ the Throttle screw must be adjusted out, counterclockwise, thus increasing the flow of gas from the gas valve to the combustion air stream. See Figure 9-6 for screw direction.

US400 Adjustments - The throttle screw for the US400 is a geared valve with a 4:1 ratio. Adjusting the throttle screw 4 complete turns will return the valve to the original location, 2 turns from fully open will completely close the valve. Typical adjustment required is 0-1/4 turn in or out from the factory setting. See Figure 9-3 for throttle screw location.

US500 Adjustments - The throttle screw for the US500 is a multiple turn valve. Typical adjustment required for Natural Gas is 0-1 full turns in or out from the factory setting. To adjust combustion for Propane Gas, turn the throttle screw all the way in (clockwise until it stops), then turn the throttle screw out (counterclockwise) 4-1/2 turns and set with a combustion analyzer. See Figure 9-4 for throttle screw location.

US600-800 Adjustments - Remove the cap and adjust the input screw by turning it clockwise to decrease gas flow and counter-clockwise to increase gas flow. Typical adjustment required is 0-1/8 turns in or out. See Figure 9-5 for throttle screw location.

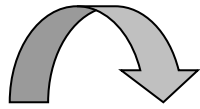
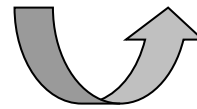
Figure 9-6 Throttle/Input Adjustment Screw (All Models)**Decrease Gas - Turn Clockwise****Increase Gas - Turn Counter Clockwise**

IF FOR ANY REASON THE INPUT SCREW IS ADJUSTED, A "COMBUSTION ANALYZER" MUST BE USED TO ENSURE SAFE AND PROPER OPERATION OF THE GAS VALVE.

WARNING

Adjustments to the Throttle screw may only be made by a qualified gas technician, while using a calibrated combustion analyzer capable of measuring CO₂ and CO. Failure to follow these instructions may result in serious injury or death.

WARNING

Adjustments to the Throttle screw may only be performed if the gas line pressure is maintained above minimum levels throughout the duration of the test; see Table 9-1. Failure to follow these instructions may result in serious injury or death.

Combustion Calibration - To calibrate burner operation, perform the following procedure using a calibrated combustion analyzer capable of measuring CO₂ and CO from Natural and Propane Gas burning appliances:

1. Operate the unit at the maximum modulation rate, see Table 9-2.
2. Ensure the gas line pressure is maintained within tolerance, see Table 9-1.
3. While at the maximum modulation rate, measure the CO₂ and CO; adjust as necessary, using the Throttle Screw, to be within the limits listed in Table 9-1.
4. Operate the unit at the minimum modulation rate (Table 9-2). Ensure the combustion remains smooth and CO₂ and CO remain within the limits (Table 9-1). If not, do not adjust further, contact ACE for assistance.

Flue Gas Analysis and Adjustment

Each Liberty US is factory set to operate with Natural Gas, for boilers field converted to operate with Propane Gas, a flue gas analysis and adjustment is mandatory. See Table 7-1 and propane conversion instructions.

DANGER

Models US400 require the installation of an LP orifice prior to operating with Propane Gas, see Propane conversion instructions for more details. To convert the US500 to operate with Propane Gas requires field calibration of the throttle/input screw; see "US500 Adjustments" in Section 9.0 and Propane conversion instructions. Models US600-800 only operate with Natural Gas; conversion to Propane is not an option. Failure to follow these instructions will result in property damage, personal injury or death.

WARNING

Failure to perform the flue gas analysis and adjustment detailed in this section may result in erratic and unreliable burner operation, leading to reduced efficiency, increased fuel consumption, reduced component life, heat exchanger combustion deposits, and general unsafe operation. Failure to follow these instructions may result in serious injury or death.

Analysis - Liberty US flue gas test ports are located in the flue outlet adapter assembly. Test port access is either from inside the boiler cabinet or from outside the boiler cabinet (US00-800; Figures 9-8 through 9-10). Remove the test port plug, perform flue gas analysis, and adjust throttle/input screw as required until CO₂ and CO levels are within acceptable limits, see Table 9-1 Line Pressure and Combustion Parameters. Once flue gas sampling completed, re-install test port plug. For model with a threaded plug, seal threads with Teflon tape before reinstalling plug.

DANGER

Failure to re-install the test port plug will result in damage to the unit, property damage, fire, explosion, serious injury or death.

Figure 9-8 Flue Gas Sampling Using Test Port (US400)

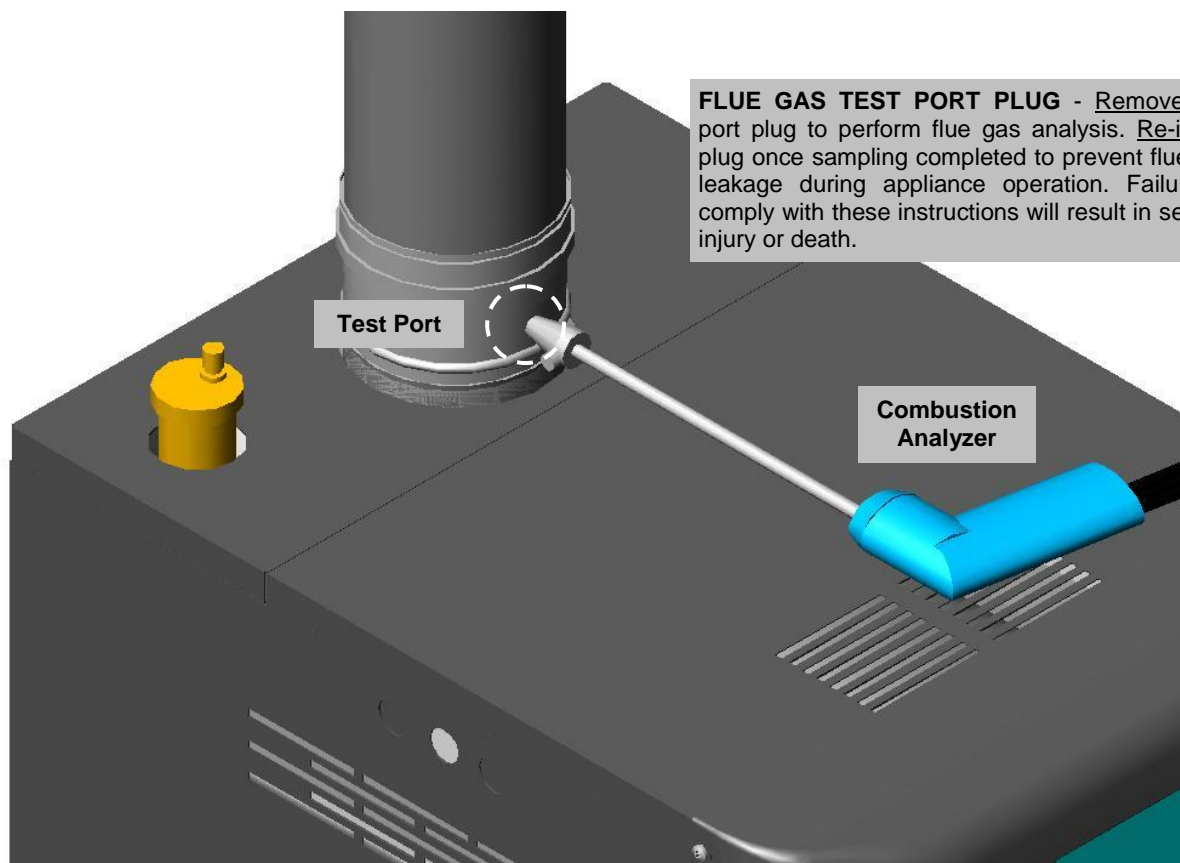

Figure 9-9 Flue Gas Sampling Using Test Port (US500-600)

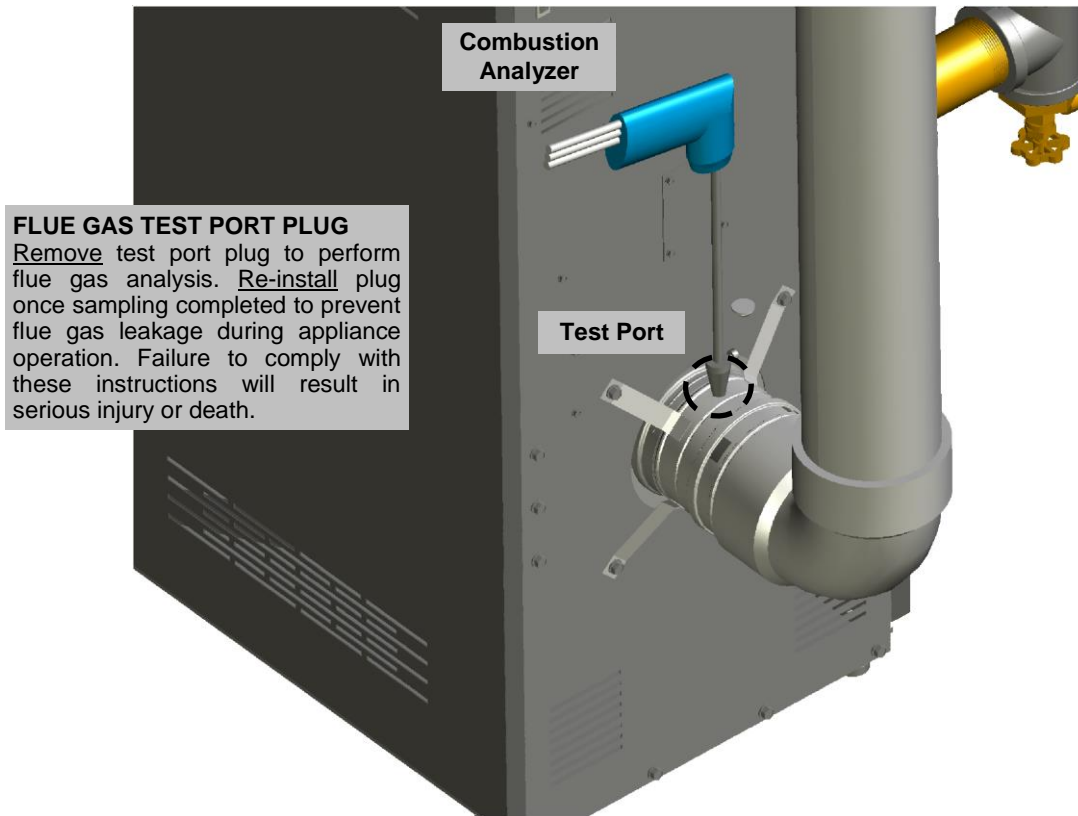
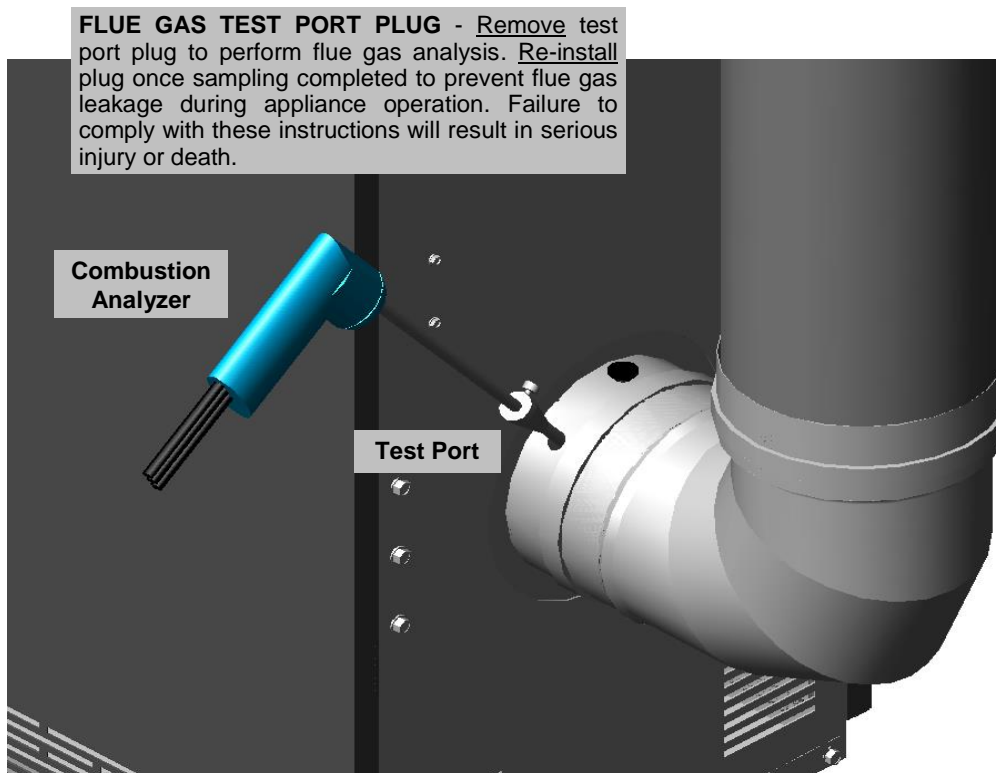

Figure 9-10 Flue Gas Sampling Using Test Port (US700-800)



10.0 BOILER AND HEATING SYSTEM PIPING

The heat exchanger of the Liberty US boiler is designed to attain the highest level of heat transfer in a compact design. To accomplish this, the heating water flows through a series of fin shaped tubes, designed to maximize the heat transfer area. To maintain the efficient and reliable operation of the heat exchanger, and to avoid heat exchanger failure, it is critical to ensure the rules and guidelines in this section are followed.



Failure to follow the instructions provided in this section will void the ACE warranty and may result in property damage, fire, serious injury or death.

Boiler System Preparation

Prior to connecting plumbing to the boiler, flush the entire system to ensure it is free of sediment, flux, solder, scale, debris or other impurities that may be harmful to the system and boiler. During the assembly of the heating system, it is important to keep the inside of the piping free of any debris including construction and copper dust, sand and dirt.

For retrofits, all system piping including radiators, must be cleansed of all build-up including sludge and scale. All systems, old and new, must be cleansed to remove flux, grease and carbon residue. ACE recommends cleansing the boiler system with “Ferrox F3 Cleaner”. For retrofit applications with heavy limescale and sludge deposits, a heavier duty cleaner may be required; ACE recommends the use of “Ferrox DS-40 System Cleaner”. For information on performing the cleansing, follow the instructions included with the Ferrox DS-40 System Cleaner. See Table 10-1 for a list of recommended boiler cleansing products.



Failure to rid the heating system of the contaminants listed above will void your ACE warranty and may result in premature heat exchanger failure and property damage.

Table 10-1 Boiler System Cleansers and Corrosion Inhibitors

Application	Ferrox Product	ACE Part #	Description
Boiler Water Treatment	F1 Protector	ACE83448	Corrosion inhibitor.
Cleanser for new and old systems	F3 Cleaner	ACE83449	Removes flux, grease and carbon residue.
Cleanser for Retrofits	DS-40 System Cleaner	ACE83450	Removes heavy limescale and sludge deposits.

Boiler Water

Pressure - The Liberty US boilers are intended solely for use in pressurized closed loop heating systems operating with a minimum pressure of 15 PSI at the boiler outlet. To obtain the minimum system design pressure, follow the piping diagrams illustrated in this section.

Oxygen Elimination - This boiler may only be installed in a pressurized closed-loop heating system, free of air (oxygen) and other impurities. To avoid the presence of oxygen, ensure all of the air is removed from the system during commissioning via strategically placed adequately sized air-removal devices, located throughout the heating system. See figures in this section detailing the location of the primary air-removal device required for the boiler. Immediately repair any leaks in the system plumbing to avoid the addition of make-up water; make-up water provides a source of oxygen and minerals that may lead to heat exchanger failure. Failure to follow these instructions will result in poor performance, unnecessary wear of system components and premature failure.

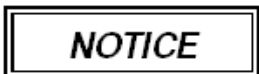

The Liberty US is not approved for operation in an “open system”, thus it cannot be used for direct potable water heating or process heating of any kind.

Water Chemistry – The installer of the Liberty US boiler must consider the condition of the water in the heating system. Ensure the condition of the boiler water falls within the following parameters:

- PH – between 7.5 and 9.5.
- Chloride – less than 125mg/l.
- Conductivity – 100 to 300µS/cm (at 25°C); [TDS 50 to 150ppm or Total Hardness 3 to 9grains/USgal.]
- Iron – less than 0.5mg/l.
- Copper – less than 0.1mg/l.

Treatment - Boiler water that falls outside of the conditions listed above must be treated with a corrosion inhibitor. Each Liberty US boiler is provided with at least 1 bottle of “Ferrox F1” corrosion inhibitor (US500-800 come with 2 bottles), adequate to treat a 26.4 gallon (100 liter) heating system to a minimum required concentration of 0.5%. Systems with greater volume will require more inhibitor. For information on performing the treatment, follow the instructions included with the Ferrox F1 Protector. See Table 10-1 for a list of recommended boiler system cleansers and corrosion inhibitors.



To maintain protection, the level of corrosion inhibitor must be monitored periodically for the correct concentration.

Anti-freeze - For systems requiring freeze protection, use only inhibited propylene glycol, specially formulated for hydronic heating systems; use of other types of antifreeze may be harmful to the system and will void the warranty. Note: the use of glycol may reduce the usable output capacity of the boiler, thus requiring the unit to be “de-rated” by limiting the maximum operating capacity and/or the maximum water temperature. ACE recommends against exceeding 35% concentration of glycol.



DO NOT use inhibited glycol with non-compatible boiler inhibitors. Non-compatible inhibitors may counteract each other rendering them ineffective.

Near Boiler Plumbing

Pressure Relief Valve - A Pressure Relief Valve is factory supplied with each unit and must be field installed at the boiler outlet in the vertical position, as shown in Figures 10-1(a) and (b), with the drain pipe outlet exiting the side of the pressure relief valve horizontally and elbowing down. US400 models come with a 30 psi relief valve, while US500-800 models come with a 50 psi relief valve. The maximum allowable working pressure (MAWP) varies with boiler model, see Table 10-2; alternate relief valves may be used, so long as they are ASME certified and meet the requirements for the respective boiler.



If installed with the incorrect orientation (horizontally with drain pipe out the bottom) the relief valve may not function properly resulting in property damage or personal injury.



Ensure the discharge of the pressure relief is piped to a location where the steam or water will not cause property damage or serious injury.

Pressure Gauge – Liberty US units come with a factory supplied Pressure Gauge. The pressure gauge must be installed at the boiler outlet, prior to any circulators, and in the vicinity of the pressure relief valve. See Figures 10-1(a) and (b).

Table 10-2 Pressure Relief Valve Specifications

Boiler Model	Maximum Pressure Relief Valve Setting / Boiler MAWP (psi)	Minimum Pressure Relief Valve Capacity (MBH)
US400	145	400
US500	160	500
US600	160	600
US700	160	700
US800	160	800
Notes:		

Figure 10-1(a) Near Boiler Piping (US400)

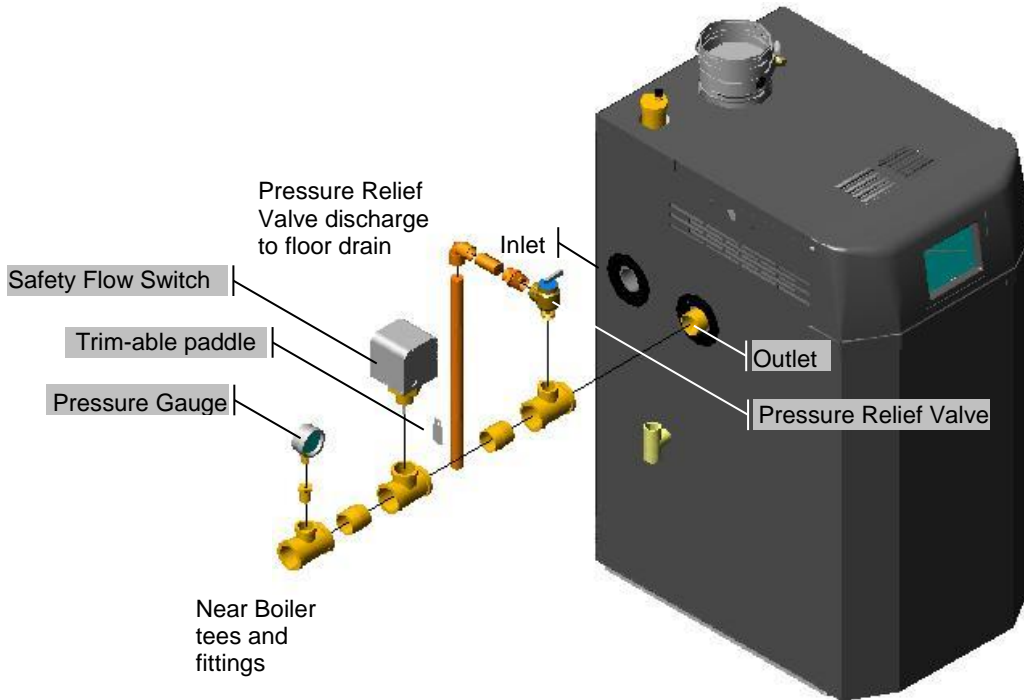
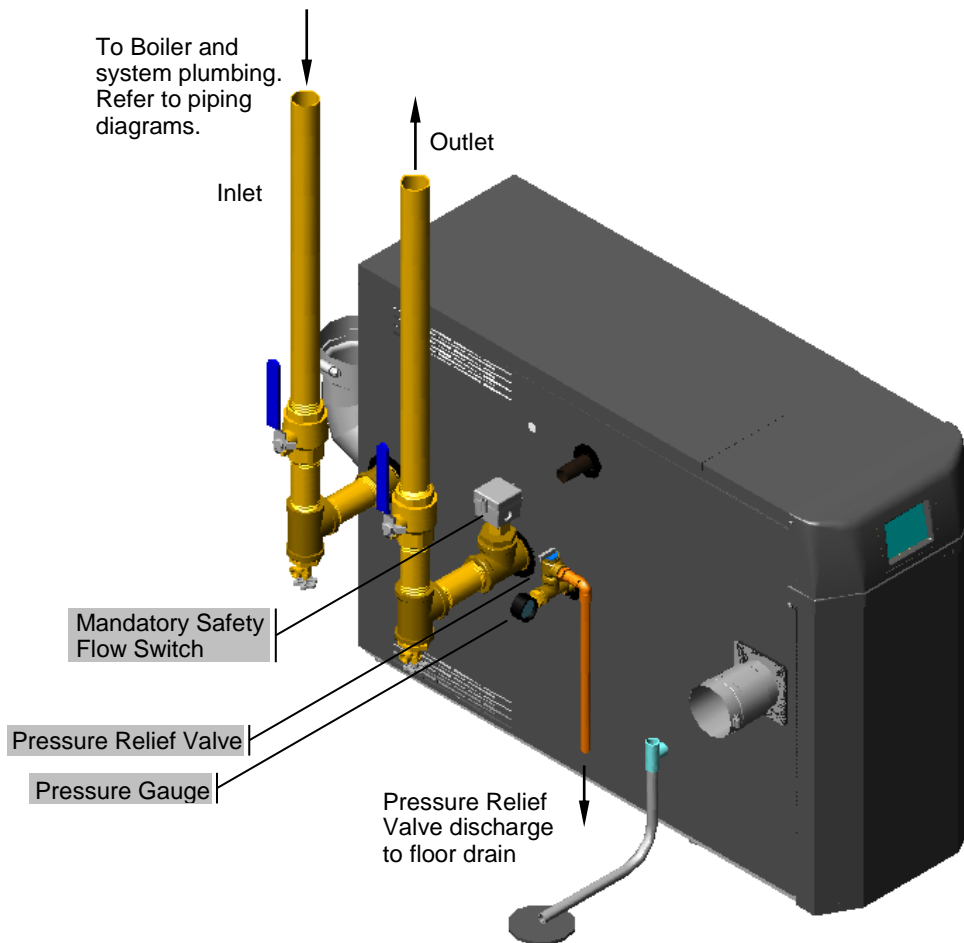

Figure 10-1(b) Near Boiler Piping (US500-800)



Low Water Cutoff (LWCO) / Safety Flow Switch – Liberty US -400 boilers are provided with a factory installed Water Pressure Switch; in the event the pressure drops below 10 psi, the burner is inhibited from firing. Where required by the Authority having jurisdiction, an external LWCO, or Safety Flow Switch, may have to be installed; see Figures 10-1(a) and (b) for Safety Flow Switch installation.

NOTICE

When using a Safety Flow Switch, it must be installed on the boiler outlet fitting (see Figure 10-1) in accordance with the instructions provided with the flow switch. Install the flow switch in a 1-1/4” diameter line for models US400.

NOTICE

Models US500-800 come equipped with a factory installed flow switch installed in a 2” diameter line. The flow switch is pre-plumbed with a Nema 4 rated enclosure and prewired via liquid-tight conduit. According to ASME CSD-1, a flow switch must be used in lieu of a Low Water Cut Off (LWCO) for a water tube boiler.

NOTICE

When external safety devices are used, such as a LWCO, Flow Switch, or a Temperature Limiting Switch, they must be wired as per the instructions provided in this manual. Refer to Section 12.0 for wiring instructions.

Boiler System Plumbing

The Liberty US boiler uses a low mass heat exchanger that requires a minimum rate of forced water circulation any time the burner is operating (See Table 10-4 for minimum flow rates). To ensure the minimum flow rate is attained, the boiler must be installed in a “Primary/Secondary” plumbing configuration utilizing “Closely Spaced Tees” to de-couple the Boiler-Primary loop from the System-Secondary loop(s) (see Figures 10-2 and 10-3 for examples). As well as a Primary/Secondary Loop Configuration utilizing closely spaced tees, a properly installed system will as a minimum include the major components in Table 10-3.

Table 10-3 System Major Component Checklist

Factory Supplied Components	Field Supplied Components
<input type="checkbox"/> Pressure Relief Valve ¹	<input type="checkbox"/> Boiler Loop Circulator (Pump B in Figure 10-2 or Pump C in Figure 10-3)
<input type="checkbox"/> Pressure Gauge	<input type="checkbox"/> DHW Loop Circulator (Pump A in Figure 10-2 and Figure 10-3, for applications utilizing Indirect Fired Water Heater only)
<input type="checkbox"/> Flow Switch (US500-800 only)	<input type="checkbox"/> Central Heat (CH) Loop Circulator(s) (CH Circulator - Pump C in Figure 10-2; Zone Circulators in Figure 10-3)
	<input type="checkbox"/> Central Air Removal Devices (i.e. Micro Bubbler or Air-Scoop)
	<input type="checkbox"/> Pressure Regulating “Fill Valve”
	<input type="checkbox"/> Backflow Preventor
	<input type="checkbox"/> Expansion Tank
Notes: ¹ Refer to Table 10-2 for a list minimum Pressure Relief Valve specifications.	

Circulating Pumps – Liberty US-400 boilers are equipped with three 120VAC pump outputs, while the US500-800 is equipped with 3 pump contacts (relays):

1. PUMP A “DHW Pump” - operates during a Domestic Hot Water demand
2. PUMP B “Boiler Pump” - operates during any demand
3. PUMP C “CH Pump” - operates during a Central Heat demand (CH1 or CH2)

Ensure pumps are oriented as per the manufacturers’ instructions. Wiring of these circulators will depend on the system configuration chosen; see Figures 10-2 and 10-3. For further wiring details see Section 12.0.

NOTICE

Circulators responsible for forcing the water flow rate through the boiler must be sized according to Table 10-4, see Figures 10-2 and 10-3 for details.

WARNING

Failure to ensure the minimum water flow rate through the boiler when the burner is on will not only reduce the operating efficiency of the boiler, but may also cause premature failure, overheating and void the warranty. Failure to follow instructions may result in fire, property damage, serious injury or death.

Table 10-4 Minimum Circulator and Pipe Sizes

Model	Restriction Head Loss	Minimum Pipe Size	Min. Flow (GPM)	Max Temp. Rise	Minimum Primary Loop Pump Size			
					B&G			
400	10' at 20	1-1/2"	16	45°F	NRF-36			
500	12' at 25	2"	20	45°F	PL-36 ¹			
600	10' at 30	2"	24	45°F	PL-55 ⁵			
700	9' at 35 GPM	2"	28	45°F	PL-55 ⁵			
800	11' at 40	2"	32	45°F	PL-55 ⁵			

Notes:

¹ NOT recommended for DHW indirect circulator when installed as per Figure 10-3, recommend higher head circulator.
⁵ B&G PL-75 and PL-130 NOT recommended.

Air Removal – The boiler and system plumbing layout must be configured to promote the removal of air from the water. Air vents and bleeders must be strategically placed throughout the system to aid in purging the air from the system during commissioning of the boiler. The system must also employ the use of a strategically located air removal device, such as an air scoop or micro-bubbler, designed to remove the air from the water as it flows through the system.

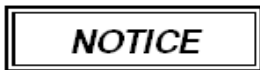

Follow the installation instructions included with the air removal device when placing it in the system; air removal devices generally work better when placed higher in the system. Always locate air removal devices in areas of the system that have a guaranteed positive pressure, e.g., in close proximity to the water fill and expansion tank.

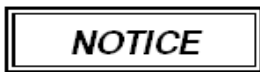

Liberty US boilers are equipped with an automatic air removal device to aid in the purging of air from the boiler during the initial fill. This device is **NOT** intended, nor is it sufficient to remove the air from the system plumbing, even if the air makes it back to the boiler. A strategically located air removal device must be installed in the system.

Expansion Tank – The expansion tank must be sized in accordance with the water volume of the system as well as the firing rate of the boiler. It is important to locate the expansion tank, and make-up water fill, on the inlet side of any circulator in the system, as doing so will guarantee the lowest pressure in the system will be at least equal to the tank and make-up water pressure. See examples in Figures 10-2 and 10-3.



Ensure the expansion tank cannot become isolated from the boiler anytime the system is operating. Failure to follow these instructions may result in discharge of the Pressure Relief Valve may result in property damage or personal injury.



The installation of flow checks, motorized valves or other shutoff devices (other than for the purpose of servicing) are not permitted between the location of the “Closely Spaced Tees” and the expansion tank; see Figures 10-2 and 10-3.

Indirect Fired Water Heater – When installed as per Figure 10-3, the indirect fired water heater is in series with the boiler during a demand for DHW. Therefore when using this configuration it is important to use an Indirect Fired Water Heater that has minimal head loss. Indirect fired water heater head loss must not exceed those specified in Table 10-5, when installed as per Figure 10-3.

Table 10-5 Maximum Indirect Fired Water Heater Head Loss (Boiler Side) at Minimum Flow

US400	9' at 16 GPM		
US500	18' at 20 GPM		
US600	18' at 24 GPM		
US700	15' at 28 GPM		
US800	12' at 32 GPM		

Figure 10-2: Single System Circulator Configuration - Often used in applications zoned with “Zone Valves”. During a demand for central heat, the boiler energizes the System Circulator via the Central Heating (CH) pump output (PUMP C). The System Circulator must be sized to provide adequate circulation throughout the heating system. During a Domestic Hot Water (DHW) demand, the boiler de-energizes the System Circulator (PUMP C) and energizes the DHW Circulator (Pump A). With this configuration the Boiler Circulator is the only pump that causes flow through the boiler and it is powered during any demand via the boiler pump output (PUMP B). This circulator must be sized according to Table 10-4.

NOTICE

The piping configuration described above requires the Central Heating system and DHW system to be de-coupled from the “Primary Loop” via closely spaced tees (Figure 10-3).

Figure 10-3: Multiple System Circulator Configuration - Often used in applications with “Zone Circulators”. This configuration requires the installation of a check valve located at each circulator. During a central heating demand the boiler energizes the Central Heat Circulator via the Central Heat pump out (PUMP C). During a Domestic Hot Water (DHW) demand, the boiler de-energizes PUMP C and energizes the DHW Circulator (Pump A). Both Pump A and C, used in this configuration, are responsible for water flow through the boiler and must be sized according to Table 10-4. Pump output, PUMP B is not used in this configuration.

NOTICE

Figures 10-2 and 10-3 illustrate typical piping systems. These piping schematics do not illustrate all of the required concepts and components required to have a proper installation. Concepts not shown include: prevention of thermal-siphoning (heat traps), isolation valves, drain and purge valves, etc. It is the responsibility of the installing contractor and system designer to determine which system best meets the need of the installation and to consider all aspects of a proper system design. Contractor modifications to these instructions may be required, based upon existing piping and system design.

Figure 10-2 Primary / Secondary Plumbing
(Single System Circulator Configuration)

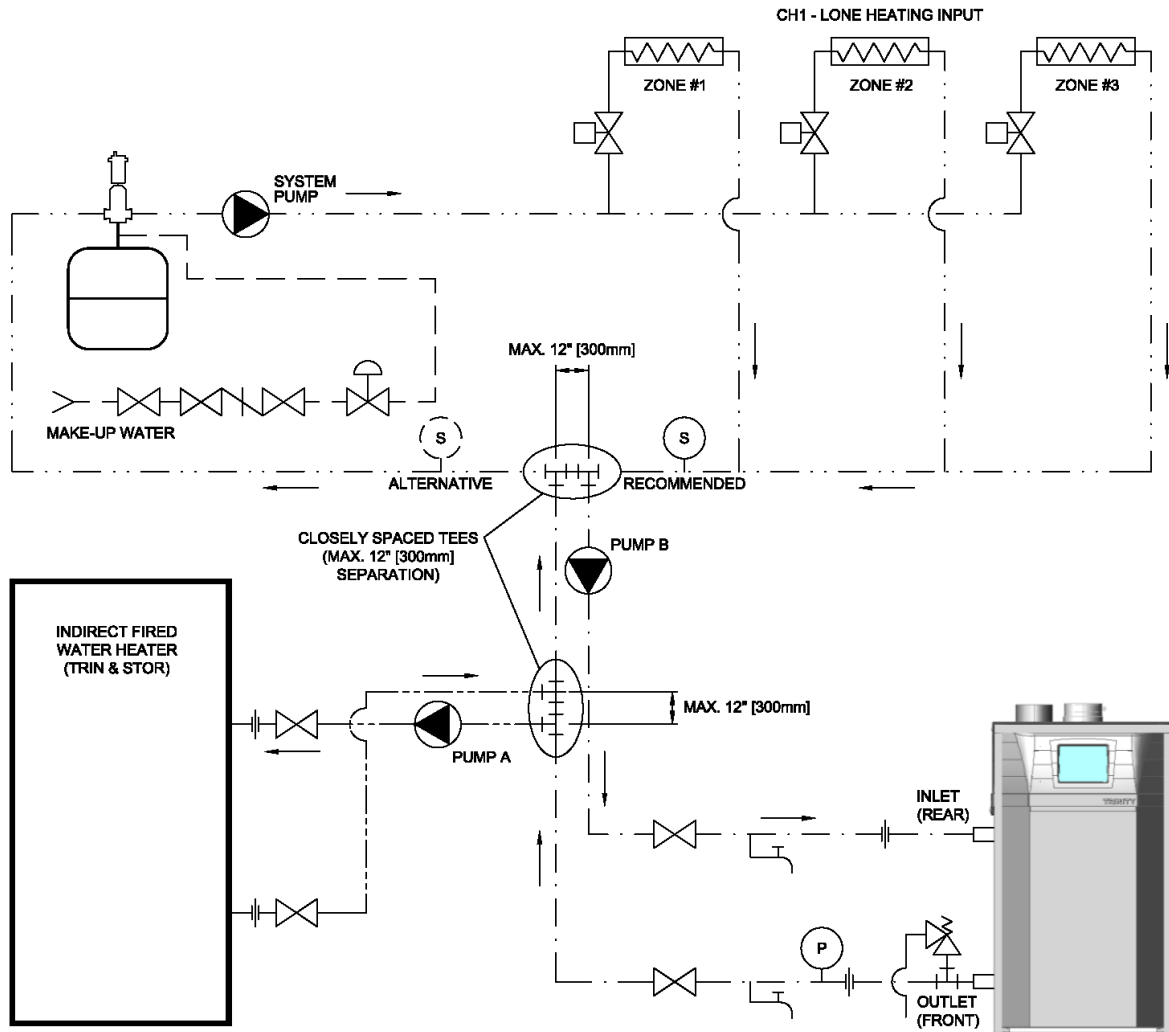

LEGEND

SYMBOL	DESCRIPTION	SYMBOL	DESCRIPTION	SYMBOL	DESCRIPTION
---	MAKE-UP WATER		BACKFLOW PREVENTOR		AIR SEPARATOR
---	PRIMARY LOOP		PRESSURE RELIEF VALVE		PUMP
---	CENTRAL HEATING SECONDARY LOOP		PRESSURE REGULATING VALVE		UNION
---	DHW SECONDARY LOOP		DRAIN VALVE		TEE
	ISOLATION VALVE		AIR VENT		FLOW DIRECTION
	ZONE VALVE		EXPANSION TANK		SYSTEM SENSOR
	ZONE LOAD		PRESSURE GAUGE		

**Figure 10-3 Primary / Secondary Plumbing
(Multiple System Circulator Configuration)**

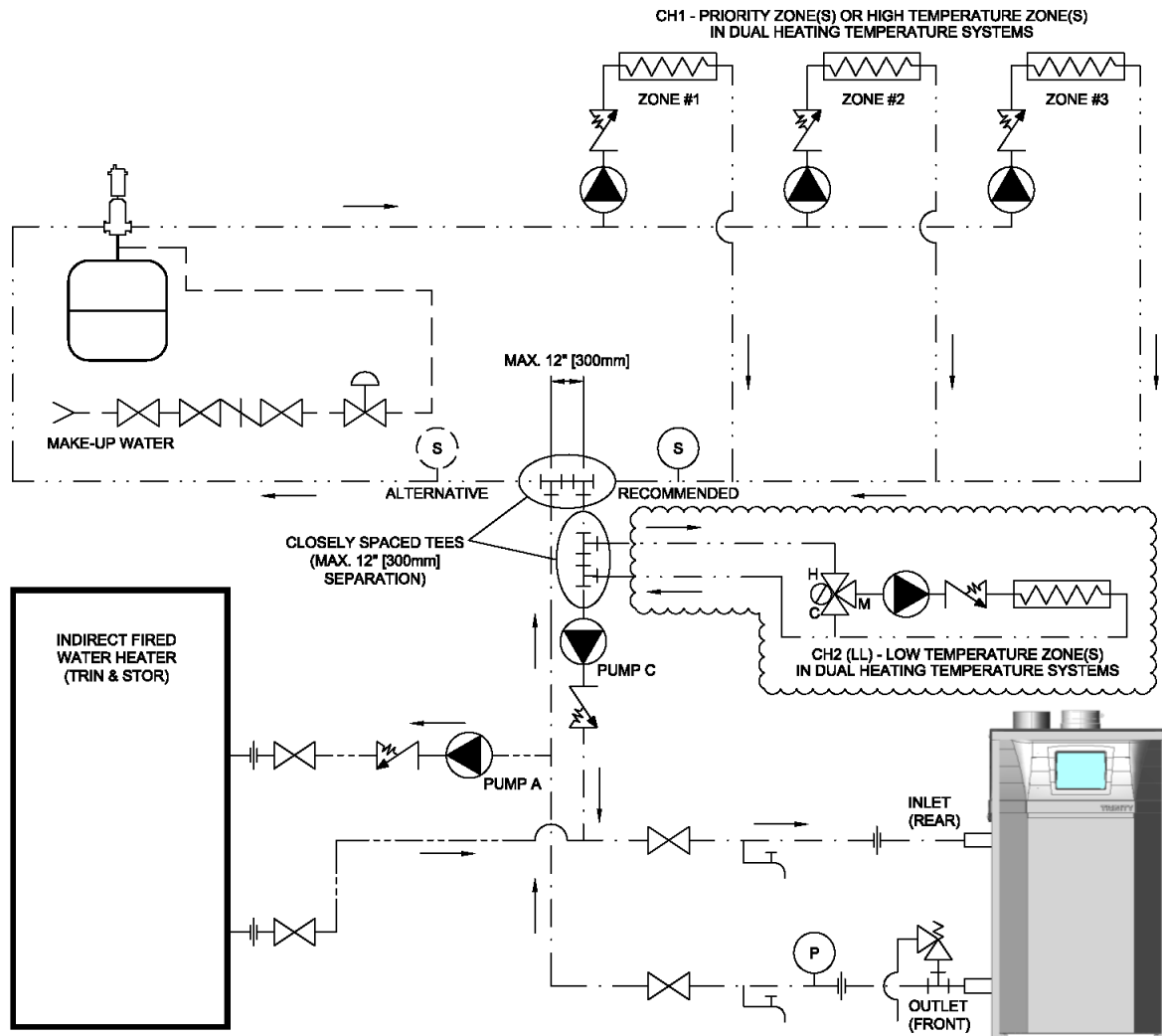

LEGEND					
SYMBOL	DESCRIPTION	SYMBOL	DESCRIPTION	SYMBOL	DESCRIPTION
---	MAKE-UP WATER		BACKFLOW PREVENTOR		AIR SEPARATOR
---	PRIMARY LOOP		PRESSURE RELIEF VALVE		PUMP
---	CENTRAL HEATING SECONDARY LOOP		PRESSURE REGULATING VALVE		UNION
---	DHW SECONDARY LOOP		DRAIN VALVE		TEE
	ISOLATION VALVE		AIR VENT		FLOW DIRECTION
	ZONE VALVE		EXPANSION TANK		SPRING CHECK VALVE
	ZONE LOAD		PRESSURE GAUGE		SYSTEM SENSOR
	THERMOSTATIC MIXING VALVE		OPTIONAL		

11.0 LEAD LAG INSTRUCTIONS

Multiple Boiler Applications

The US controller has the internal capacity to stage or Lead-Lag up to 8 boilers configured in a cascade. This Lead-Lag capability allows a designated “Master” boiler to communicate with and effectively control each boiler in a multiple boiler system. This function is accomplished by “Daisy Chaining” a 3-wire cable between each of the boilers and enabling the Master parameter in the boiler of your choice. The boiler with the Master parameter enabled becomes the single point of contact for Central Heating, Domestic Hot Water and Outdoor Reset settings and control. Use the instructions detailed in this section to set-up and install the cascade boiler system; reference *Appendix A – Controller and Touchscreen Display Instructions* for details on more advanced settings and for assistance with navigating the touchscreen display.

Lead Lag Instructions - Common

Plumbing – install as many as 8 US boilers in parallel in a primary/secondary plumbing configuration as illustrated in Figure 11-1. Size common piping as per Table 11-1.

Boiler Pump – each boiler must have its own circulator (see Figure 11-1) which is controlled by its *PUMP B* output; see *Field Wiring* Figures and Tables 12-1(a) and 12-1(b). The Boiler Pump must be sized according to Table 10-4.

Communication Wiring – using 3-wire cable, daisy-chain terminals *LL DATA +*, *LL DATA –* and *SENSOR COM* of each boiler in parallel; see *Field Wiring* Tables 12-2(a) and 12-2(b) and Figure 12-2.

System Sensor (Optional) – install a system sensor (ACE P/N: ACE84010) on the outlet (supply) pipe feeding the heating system, see Figure 11-1. Wire the system sensor to *SENSOR COM* and *SYSTEM (OD / SYS SENSOR* for US500-800 models) of the Master Boiler; see *Field Wiring* Tables 12-2(a) and 12-2(b) and Figure 12-2. The system sensor automatically becomes the modulation sensor for the boiler system, i.e. the control attempts to achieve setpoint temperature at the location of the sensor. If a system sensor is **NOT** used, at the Master boiler set the applicable sensor input to *Unconfigured* as follows:

Configure – Sensor Configuration – S10 (J10-7) sensor [S5 (J8-11) sensor for US500-800 models]

Outdoor Sensor (Optional) – wire the outdoor sensor to *SENSOR COM* and *OD SENSOR (OD / SYS SENSOR* for US500-800 models) of any one of the boilers in the cascade (for US500-800 models, outdoor sensor must be connected to a non-Master boiler); see *Field Wiring* Tables 12-2(a) and 12-2(b) and Figure 12-2. Note: only one outdoor sensor is needed for the multiple boiler system.

Modbus Address – assign a unique *MB2 Modbus Address* to each boiler in the cascade. Access the *MB2 Modbus Address* setting via the *System Identification & Access* menu as follows:

Configure – System Identification & Access – MB2 Modbus Address

Master Enable – choose **one** (and only one) boiler in the cascade to be the Master, this boiler will receive all control wiring and will be used for setting control parameters (see steps below). On this one boiler, set *Master enable* equal to *Enabled* via the *Lead Lag Master Configuration* menu, accessed as follows:

Configure – Lead Lag Master Configuration – Master enable

Table 11-1 Minimum Pipe Sizes for Multiple Boiler Applications

# of Units	US400	US500	US600	US700	US800			
2	2-1/2"	2-1/2"	3"	3"	3"			
3	3"	3"	3"	4"	4"			
4	3"	4"	4"	4"	4"			
5	4"	4"	4"	4"	5"			
6	4"	4"	4"	5"	5"			
7	4"	4"	5"	5"	5"			
8	4"	5"	5"	5"	5"			

Figure 11-1 All Models
Multiple Boiler Lead-Lag Plumbing Configuration

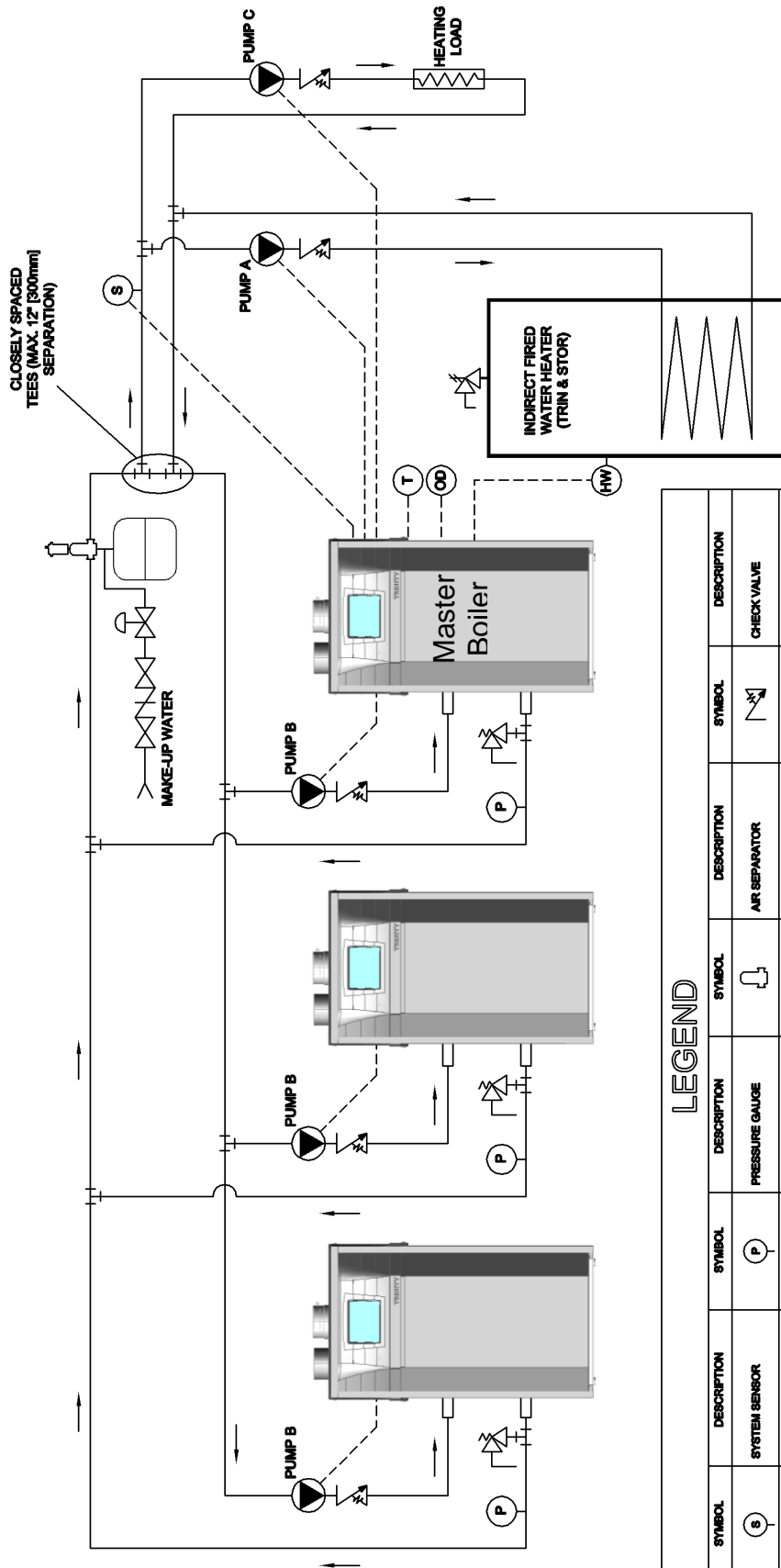

LEGEND

SYMBOL	DESCRIPTION	SYMBOL	DESCRIPTION	SYMBOL	DESCRIPTION	SYMBOL	DESCRIPTION
(S)	SYSTEM SENSOR	(P)	PRESSURE GAUGE	↓	AIR SEPARATOR	↗	CHECK VALVE
(T)	CH2 THERMOSTAT	—	WATER PIPING	↑	AIR VENT	↕	BACKFLOW PREVENTOR
(OD)	OUTDOOR SENSOR	- - -	WRING	☐	EXPANSION TANK	⊗	PRESSURE REGULATING VALVE
(HW)	TANK THERMOSTAT	→	FLOW DIRECTION	⊞	HEATING LOAD	⊠	PUMP

Lead Lag Instructions – Central Heating

Central Heat Demand Switch (Room Thermostat) – connect to *R (24VAC)* and *CH2 (LL)* of the Master Boiler; see *Field Wiring* Tables 12-2(a) and 12-2(b) and Figure 12-2. Switch must be an isolated end switch (dry contact).

Central Heat Setpoint – at the Master boiler only, set the *CH setpoint* via the *Lead Lag Master Configuration* menu, accessed as follows:

Configure – Lead Lag Master Configuration – CH setpoint

Outdoor Reset Settings – at the Master boiler only, set the *Outdoor reset* parameters via the *Lead Lag Master Configuration* menu, accessed as follows:

Configure – Lead Lag Master Configuration – Advanced Settings – Outdoor reset

CH Pump – one boiler in the cascade can be chosen to operate the Central Heating pump via its *PUMP C* output; see *Field Wiring* Figures and Tables 12-1(a) and 12-1(b). From the respective boiler display, check the box next to *Use for Lead Lag Master demands* for the CH Pump to ensure proper pump behavior. Menu access to the CH Pump parameters is as follows:

Configure – Pump Configuration – Central Heat pump – Use for Lead Lag Master demands

Sensor Configuration (US500-800 models only) – at the Master boiler only, set the *Outdoor temperature source* equal to *Unconfigured*, via the *Sensor Configuration* menu as follows:

Configure – Sensor Configuration – Outdoor temperature source

Lead Lag Instructions – Domestic Hot Water

Tank Thermostat – connect to *SENSOR COM* and *DHW* of the Master Boiler; see *Field Wiring* Tables 12-2(a) and 12-2(b) and Figure 12-2. Switch must be an isolated end switch (dry contact).

DHW Setpoint – at the Master boiler only, set the *DHW setpoint* via the *Lead Lag Master Configuration* menu, accessed as follows:

Configure – Lead Lag Master Configuration – DHW setpoint

DHW switch (Lead Lag) – at the Master boiler only, set *DHW switch* equal to *DHW (S6) sensor shorted* via the *Lead Lag Master Configuration* menu, accessed as follows:

Configure – Lead Lag Master Configuration – Advanced Settings – Domestic Hot Water – DHW switch

DHW enable (Local) – at the Master boiler only, set *DHW enable* equal to *Disabled* via the *Domestic Hot Water Configuration* menu, accessed as follows:

Configure – Domestic Hot Water Configuration – DHW enable

DHW Pump – one boiler in the cascade can be chosen to operate the DHW pump via its *PUMP A* output; see *Field Wiring* Figures and Tables 12-1(a) and 12-1(b). From the respective boiler display, check the box next to *Use for Lead Lag Master demands* for the DHW Pump to ensure proper pump behavior. Menu access to the DHW Pump parameters is as follows:

Configure – Pump Configuration – DHW pump – Use for Lead Lag Master demands

NOTICE

Tank Sensor – when operating in a cascade system, the boiler controls do not support the use of a tank sensor; a tank thermostat (switch) must be used.

12.0 FIELD WIRING

All wiring must be in accordance with the Canadian Electrical code, CSA C22.2 and any applicable local codes. Ensure that the wiring complies with this manual. The boiler must be electrically grounded in accordance with the National Electrical Code ANSI/NFPA 70, local codes, and/or the Canadian Electrical Code CSA C22.1.



Avoid Shocks - To Avoid Electrical Shock, turn off electrical power to the boiler prior to opening any electrical box within the unit. Ensure the power remains off while any wiring connections are being made. Failure to follow these instructions may result in component failure, serious injury or death.



Field Wiring - Wire grommets must be used to secure wiring and prevent chafing when passing wiring through the cabinet wall. Failure to follow instructions may damage unit.

Line Voltage Connections

Electrical rating for the Liberty US is 120V/1 Phase/60 Hz/12A. On US400 models, the line voltage junction box is located at the top of the boiler cabinet on the right hand side and can be accessed by removing the top front cover of the boiler. On US500-800 models, the line voltage junction box is located at the back of the boiler cabinet on the power switch side. Remove the top back cover of the boiler to access the three holes / knockouts needed for routing field wiring into the line voltage junction box. Line voltage field connections are to be installed in accordance with Figures and Tables 12-1(a) and 12-1(b).

Fuses (120VAC) – The Liberty US is equipped with either one or two 7 Amp fuses to protect 120VAC system components. The fast-acting fuses are located on the front of the control panel box and can be easily accessed from the outside of the control panel.

US400 Control Panel:

- Fuse A: Protects the blower, spark generator and PUMP B output circuits.
- Fuse B: Protects PUMP A and PUMP C output circuits.

US500-800 Control Panel:

- Fuse A: Protects the 120VAC circuits within the boiler.

Pump Relays (US500-800) – In lieu of the 120VAC pump outputs, the US500-800 incorporates three non-powered isolation relay contacts for switching high capacity pumps. Contact Secondary Maximum rating is 1.5HP @ 120V, 3.0HP @ 240V, or 30A. Refer to Figure 12-2(b) for Field Wiring requirements.



Wire Protection - When passing any wiring through the cabinet of the boiler, the installer must use wire grommets suitable for securing the wiring and preventing chafing. Failure to follow instructions may result in component failure, serious injury or death.



Power Supply - The Liberty US is designed to be powered using a single phase 120VAC power supply that is fused (or protected via a circuit breaker) to allow a maximum of 15 Amps. Failure to follow instructions may result in component failure, serious injury or death.



Labeling - Label all wires prior to disconnecting them when servicing controls. Wiring errors can cause improper and dangerous operation. Failure to follow instructions may result in property damage or personal injury.



Continuity - Before connecting the line voltage wiring, perform a continuity check between all wires and ground to make sure that there are no electrical leaks that could blow a fuse or damage electrical components. Also check the polarity of the line and neutral wires. Line must measure 120VAC to ground; neutral must measure zero. Failure to follow instructions may damage the unit.

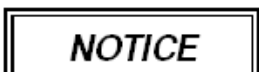

Max Load – US400 circulator outputs are each limited to operating a circulator with a maximum current load of 3 Amps or a maximum 1/6 hp motor. See Table 12-1.

Figure 12-1(a) Line Voltage Field Wiring (US400)

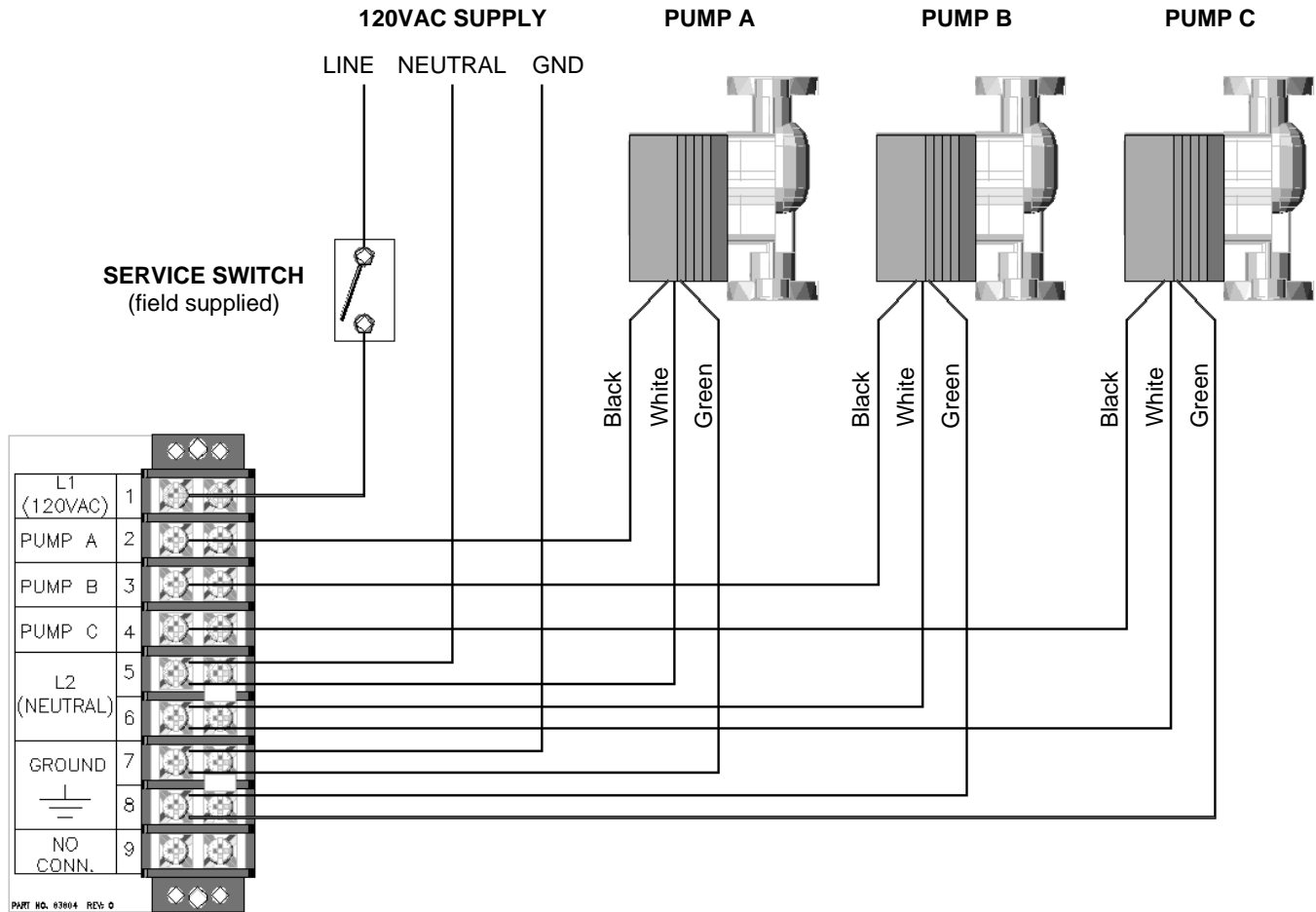

Table 12-1(a) Line Voltage Field Connections (US400)

Connection	Location	Description
L1 (120VAC)	1	Location for connecting line voltage of the power supply. Note; most installation codes require the installation of a service switch to break line voltage to the boiler.
PUMP A	2	120VAC output to the DHW circulator; powered during a demand for DHW.
PUMP B	3	120VAC output to the Boiler circulator; powered during all demands; DHW, local Central Heat (CH1) and Lead-Lag Central Heat [CH2 (LL)]. This output is not used for all plumbing configurations, see Section 10.0.
PUMP C	4	120VAC output to the Central Heating circulator; powered during a demand for local Central Heat (CH1) or Lead-Lag Central Heat [CH2 (LL)].
L2 (Neutral)	5	Location for connecting neutral of the power supply and all circulators.
	6	
Ground	7	Location for connecting earth ground and for grounding all of the circulators.
	8	
No Conn.	9	This terminal is used only for factory wiring, do not add or remove wires from this location.

Figure 12-1(b) Line Voltage Wiring (US500-800)

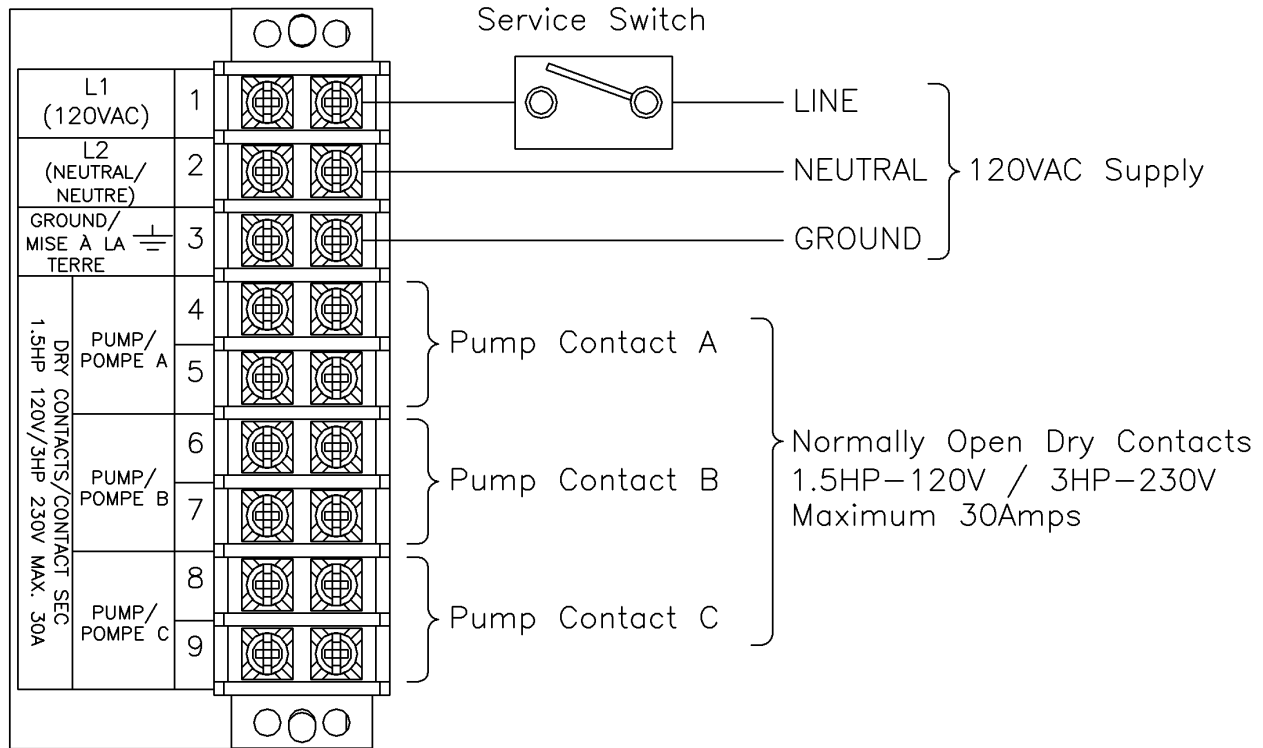

Table 12-1(b) Line Voltage Field Connections (US500-800)

Connection	Location	Description	
L1 (120VAC)	1	Location for connecting line voltage of the power supply. Note, most installation codes require the installation of a service switch to break line voltage to the boiler.	
L2 (Neutral)	2	Location for connecting neutral of the power supply.	
Ground	3	Location for connecting earth ground.	
Non-Powered Dry Contacts	PUMP A	4	Dry Contacts for DHW circulator; Coil A powered during a demand for DHW, closing Pump A relay contacts.
		5	
	PUMP B	6	Dry Contacts for Boiler circulator; Coil B powered during all demands; DHW, local Central Heat (CH1) and Lead-Lag Central Heat [CH2 (LL)], closing Pump B relay contacts. This output is not used for all plumbing configurations, see Section 2.0.
		7	
	PUMP C	8	Dry Contacts for Central Heating circulator; Coil C powered during a demand for local Central Heat (CH1) or Lead-Lag Central Heat [CH2 (LL)], closing Pump C relay contacts.
		9	

Low Voltage Connections

On US400 models, the low voltage junction box is located at the top of the boiler cabinet on the left hand side and can be accessed by removing the top front cover of the boiler. On US500-800 models, the low voltage junction box is located at the back of the boiler cabinet and can be accessed by removing the top back cover of the boiler. Each boiler is provided with one hole and two knockouts for routing field wiring into the low voltage junction box. Low voltage field connections identified in Tables 12-2(a) and 12-2(b) are to be read in conjunction with Figure 12-2.

Table 12-2(a) Low Voltage Field Connections (US400)

Connection		Location	Description
COM (24VAC)		1	24VAC Common – Neutral for the 24VAC power supply from the boiler. COM can be used in conjunction with terminal R to provide a power source for a digital thermostat.
R (24VAC)		2	24VAC Hot - Power supply for inputs LIM, CH1, and CH2 (LL).
		3	
LIM		4	External Limit – Input requiring 24VAC from terminal R to permit the burner to operate. Comes factory equipped with a jumper to the R terminal. For installations requiring the use of an additional safety switch, such as a LWCO, Flow Switch, or auxiliary temperature limit, remove the factory installed jumper and install the normally open isolated contacts of the additional limit in its place.
CH1		5	Local Central Heat Demand – Input requiring 24VAC from terminal R to initiate a “local” CH call. Switch is made using an isolated end switch (dry contact) via thermostat, zone controller or other device. Typically used as the lone heat input or as the high temperature input in dual CH temperature systems.
CH2 (LL)		6	Lead-Lag Central Heat Demand – Input requiring 24VAC from terminal R to initiate a “lead-lag” CH call. Switch is made using an isolated end switch (dry contact) via thermostat, zone controller or other device. Typically used as a lead-lag input for cascaded boilers or as the low temperature input in dual CH temperature systems.
Sensor	DHW	7	DHW Tank Demand – Input requiring closure of terminals 7 and 10 to initiate a demand for DHW. Switch made via isolated end switch (dry contact) from a thermostat (Aquastat) located in an Indirect Fired Water Heater. Or optional Tank Sensor (P/N ACE84632), see Appendix A. (NOTICE : tank sensor cannot be used for cascade boiler arrangements).
	OD SENSOR	8	Outdoor Temperature Sensor – A wall mountable OD Sensor is included with each boiler. When connected to terminals 8 and 10, the control will indicate the outdoor temperature and adjust the boiler temperature set point during a Central Heat demand.
	SYSTEM	9	System Water Temperature – An optional strap-on System Sensor is available from ACE (P/N ACE84010). When connected to terminals 9 and 10, the control will indicate a “CH” or “Lead-Lag” temperature. The control can be set to use the System Sensor as the Modulation Sensor for a CH1 or Lead Lag demand; see Appendix A.
	SENSOR COM	10	System Common – Common port for field inputs DHW, OD Sensor, System Sensor and Communication terminals.
4-20mA		11	External Modulation Control – Using a 4-20mA signal, an external control can be used to directly modulate the burner firing rate or adjust the active set point. This can be useful for applications using external staging controls or Building Automation Systems.
		12	
Communications	LL DATA+	13	Lead-Lag – Connects internally to the controller’s MB2, Modbus communication port. Terminals 13, 14 and 10 (common) can be “daisy-chained” to multiple boilers (up to 8 in total) for the purpose of staging.
	LL DATA–	14	
	BMS D+	15	Building Management System (BMS) – Connects internally to the display’s COM2, Modbus communication port. Terminals 15, 16 and 10 (common) can be connected to a Gateway for communication to a BMS or other device.
	BMS D–	16	
ALARM		17	Normally Open Alarm Contacts – Contacts close during a lockout or other alarm condition. May be connected to a BMS, maximum capacity of 0.63Amps at 24VAC.
		18	

Table 12-2(b) Low Voltage Field Connections (US500-800)

Connection		Location	Description
COM (24VAC)		1	24VAC Common – Neutral for the 24VAC power supply from the boiler. COM can be used in conjunction with terminal R to provide a power source for a digital thermostat.
R1/R2 (24VAC)		2	24VAC Hot - Power supply for inputs EXT. LIM, CH1, and CH2 (LL).
		3	
EXT. LIM		4	External Limit – Input requiring 24VAC from terminals R1/R2 to permit the burner to operate. Comes factory equipped with a jumper to the R2 terminal. For installations requiring the use of an additional safety switch, such as a LWCO or auxiliary temperature limit, remove the factory installed jumper and install the normally open isolated contacts of the field supplied additional limit in place of jumper.
GAS LO PR.		5	Gas Low Pressure Switch (Optional) – Comes factory equipped with a jumper. For applications requiring a Low Gas Pressure Switch, remove jumper and connect normally open isolated contacts of the Gas Low Pressure Switch. Switch must be installed external to unit (24VAC circuit). For preapproved High Gas Pressure Switch, see Note 1 below.
		6	
AUX. PROOF		7	Auxiliary Proof – Comes factory equipped with a jumper. For applications using Indoor Combustion Air, remove jumper and replace with field supplied end switch incorporated with motorized damper/louver control.
		8	
CH1		9	Local Central Heat Demand – Input requiring 24VAC from terminal R to initiate a “local” CH call. Switch is made using an isolated end switch (dry contact) via thermostat, zone controller or other device. Typically used as the lone heat input or as the high temperature input in dual CH temperature systems.
CH2 (LL)		10	Lead-Lag Central Heat Demand – Input requiring 24VAC from terminal R to initiate a “lead-lag” CH call. Switch is made using an isolated end switch (dry contact) via thermostat, zone controller or other device. Typically used as a lead-lag input for cascaded boilers or as the low temperature input in dual CH temperature systems.
Sensor	DHW	11	DHW Tank Demand – Input requiring closure of terminals 11 and 14 to initiate a demand for DHW. Switch made via isolated end switch (dry contact) from a thermostat (aquastat) located in an Indirect Fired Water Heater. Or optional Tank Sensor (P/N ACE84632), see Appendix A. (NOTICE: tank sensor cannot be used for cascade boiler arrangements).
	OD / SYS SENSOR	12	Outdoor Temperature Sensor – A wall mountable OD Sensor is included with each boiler. When connected to terminals 12 and 14, the control will indicate the outdoor temperature and adjust the boiler temperature set point during a Central Heat demand. System Water Temperature – An optional strap-on System Sensor is available from ACE (P/N ACE84010). When connected to terminals 12 and 14, the control will indicate a “Lead-Lag” temperature. By default, the System Sensor becomes the Modulation Sensor for a Lead Lag demand. NOTICE: only one sensor can be connected to terminal 12 (System OR Outdoor Sensor); see instructions in Appendix A.
	TOD	13	Time of Day (Night Time Setback) – Input requiring closure of terminals 13 and 14 to initiate TOD setback setting. Switch is made using an isolated end switch (dry contact) using a timer, BAS or other device. [TOD applicable to and available on US500-800 only]
	SENSOR COM	14	System Common – Common port for field inputs DHW, OD Sensor and System Sensor.
4-20mA (- / +)		15	External Modulation Control – Using a 4-20mA signal, an external control can be used to directly modulate the burner firing rate or adjust the active set point. This can be useful for applications using external staging controls or Building Automation Systems.
		16	
Communications	LL DATA+	17	Lead-Lag – Connects internally to the controller’s MB2, Modbus communication port. Terminals 17, 18 and 14 (common) can be “daisy-chained” to multiple boilers (up to 8 in total) for the purpose of staging.
	LL DATA-	18	
	BMS D+	19	Building Management System (BMS) – Connects internally to the display’s COM2, Modbus communication port. Terminals 19, 20 and 14 (common) can be connected to a Gateway for communication to a BMS or other device.
	BMS D-	20	
ALARM (A&B)		21	Normally Open Alarm Contacts – Contacts close during a lockout or other alarm condition. May be connected to a BMS, maximum capacity of 0.63Amps at 24VAC.
		22	

Notes

¹ For applications requiring a High Gas Pressure Switch, see supplemental instructions included with ACE High Gas Pressure Switch Kit, P/N ACE84094. Note that this is the only High Gas Pressure Switch that has been tested with the unit and preapproved for field installation within the boiler cabinet.

CAUTION

Low Voltage Terminals - Terminals 2 and 3 (R) have 24VAC potential from the internal transformer. Do not connect power from these terminals to any other terminal other than terminals 4, 5 and 6 [LIM, CH1, and CH2 (LL)]. Failure to follow these instructions may damage the unit.

NOTICE

Fuse (24VAC) - Liberty US-400 models are equipped with a “blade style” 2 Amp fuse to protect the internal transformer located within the slide-out control panel box.

Figure 12-2 Low Voltage Field Wiring (All Models)

US400 Illustrated

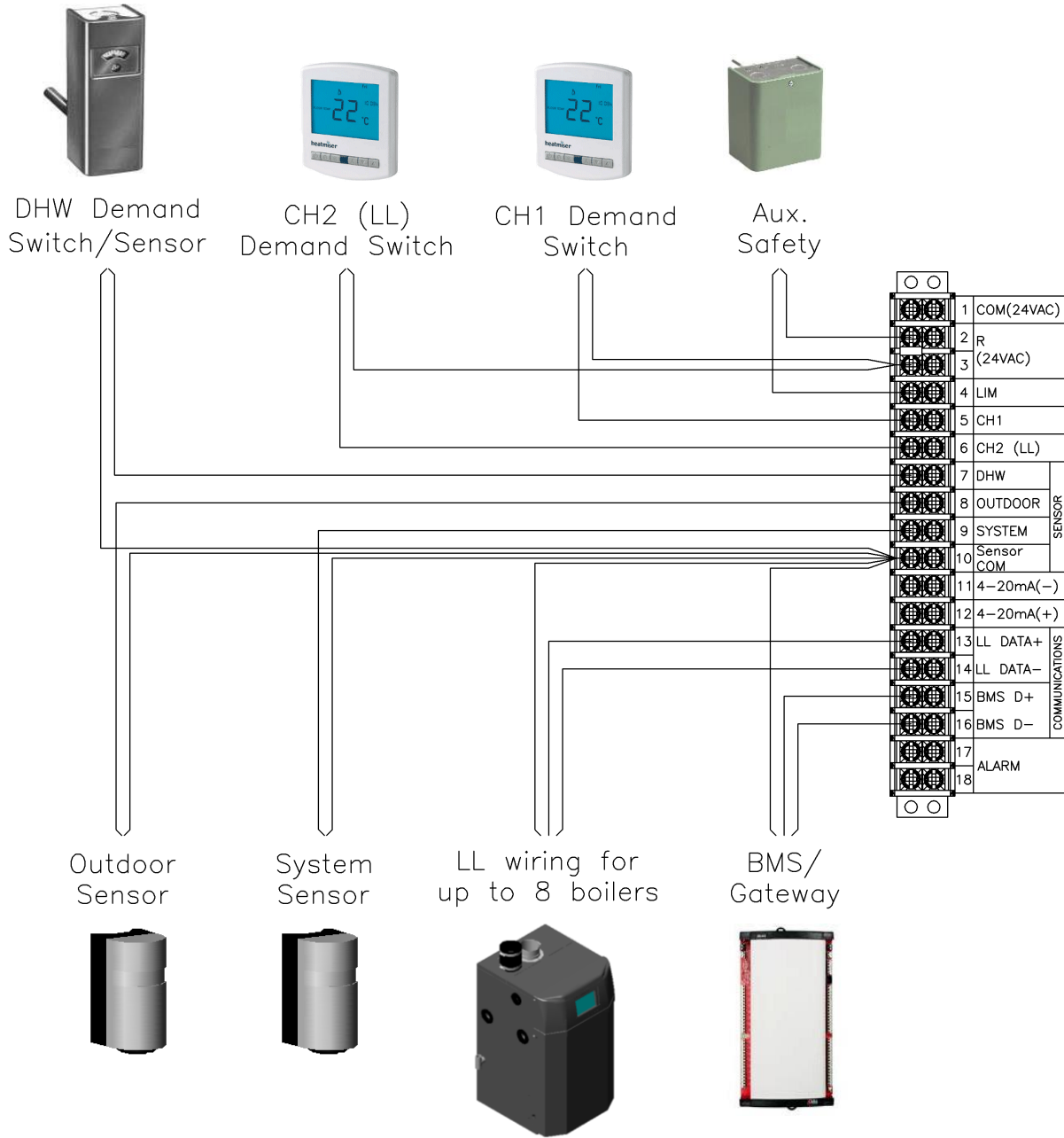

13.0 WIRING SCHEMATICS

Figure 13-1(a) Connection Diagram (US400)

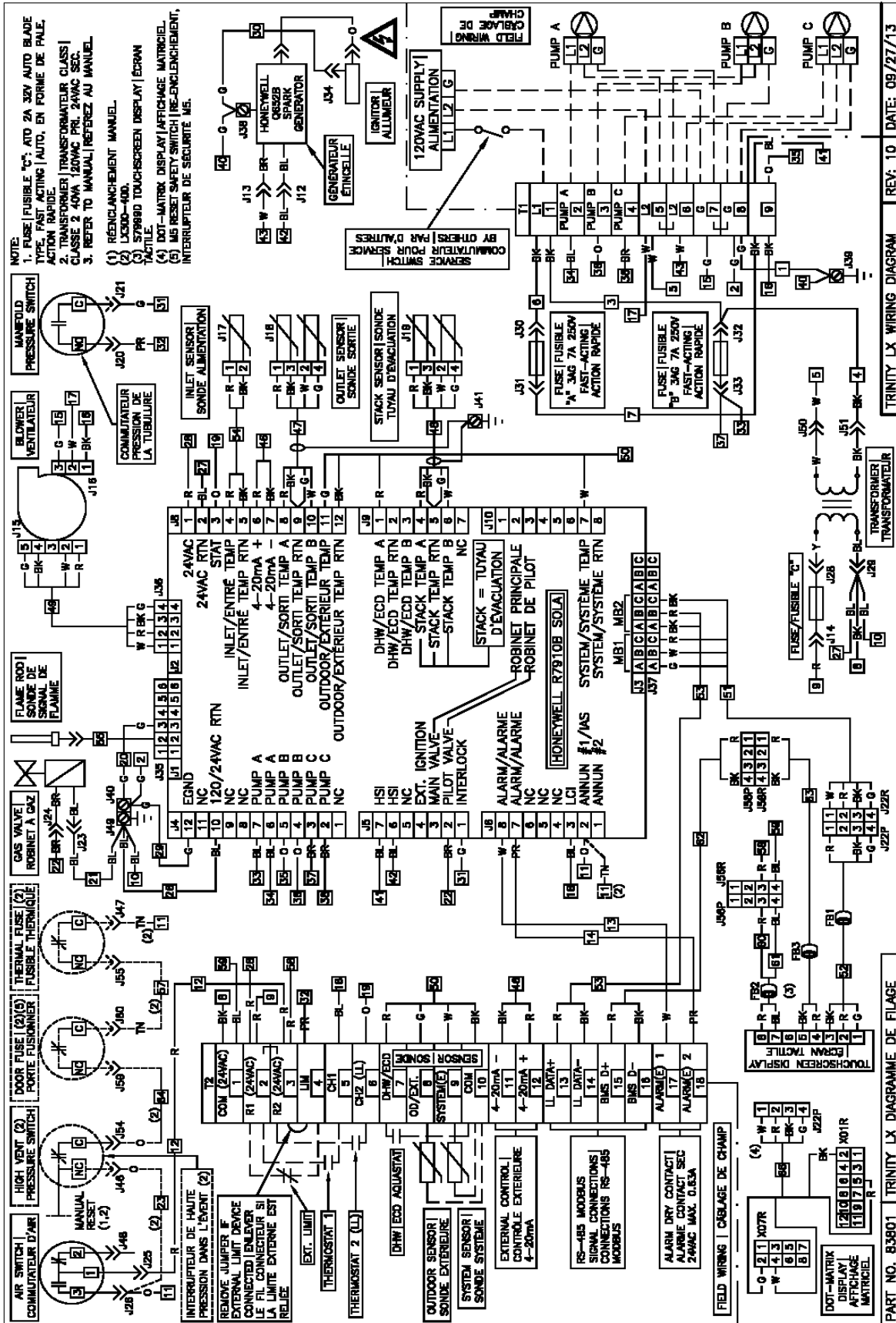

Figure 13-1(b) Ladder/Logic Diagram (US400)

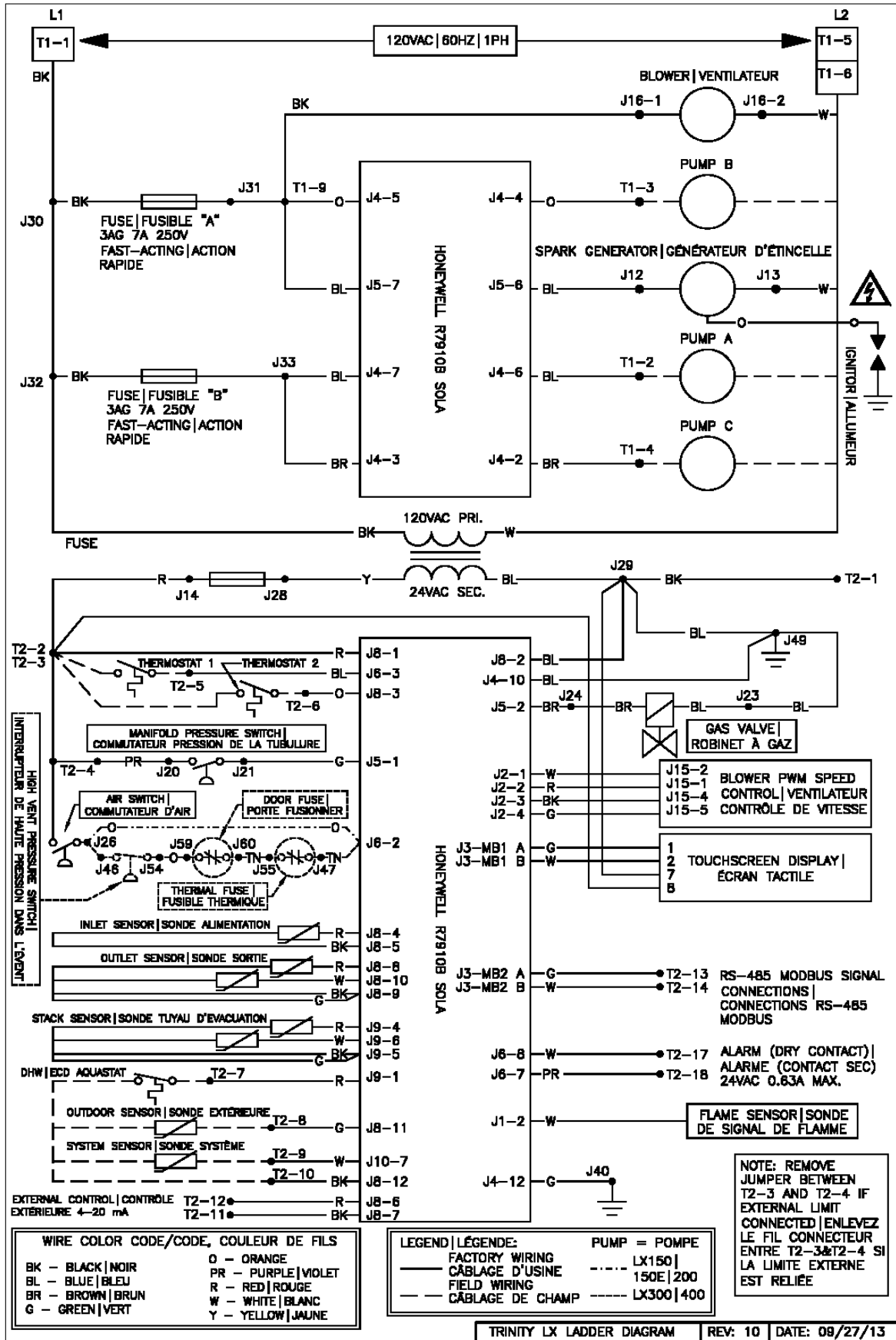

Figure 13-2(a) Connection Diagram (US500-800)

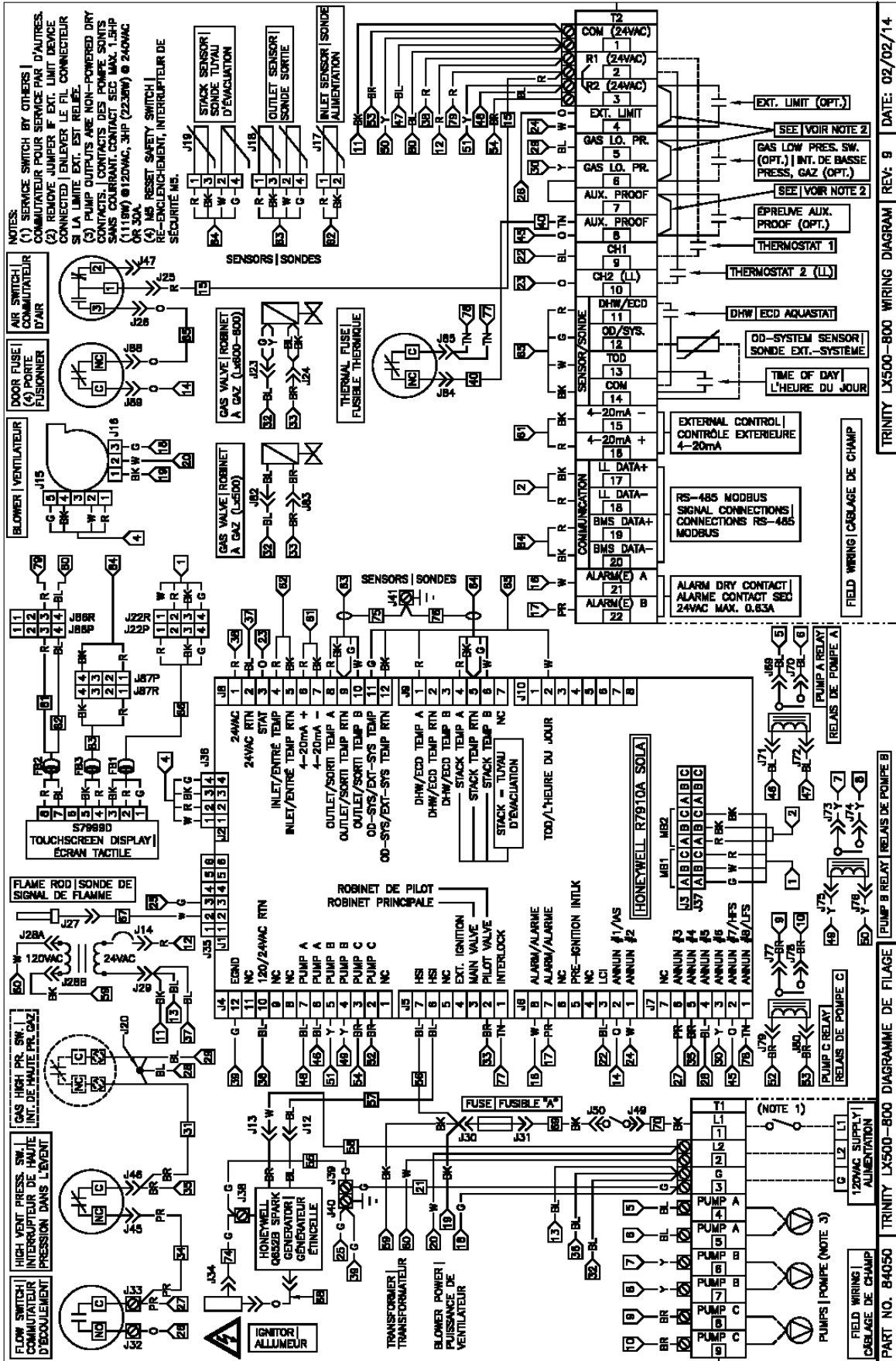
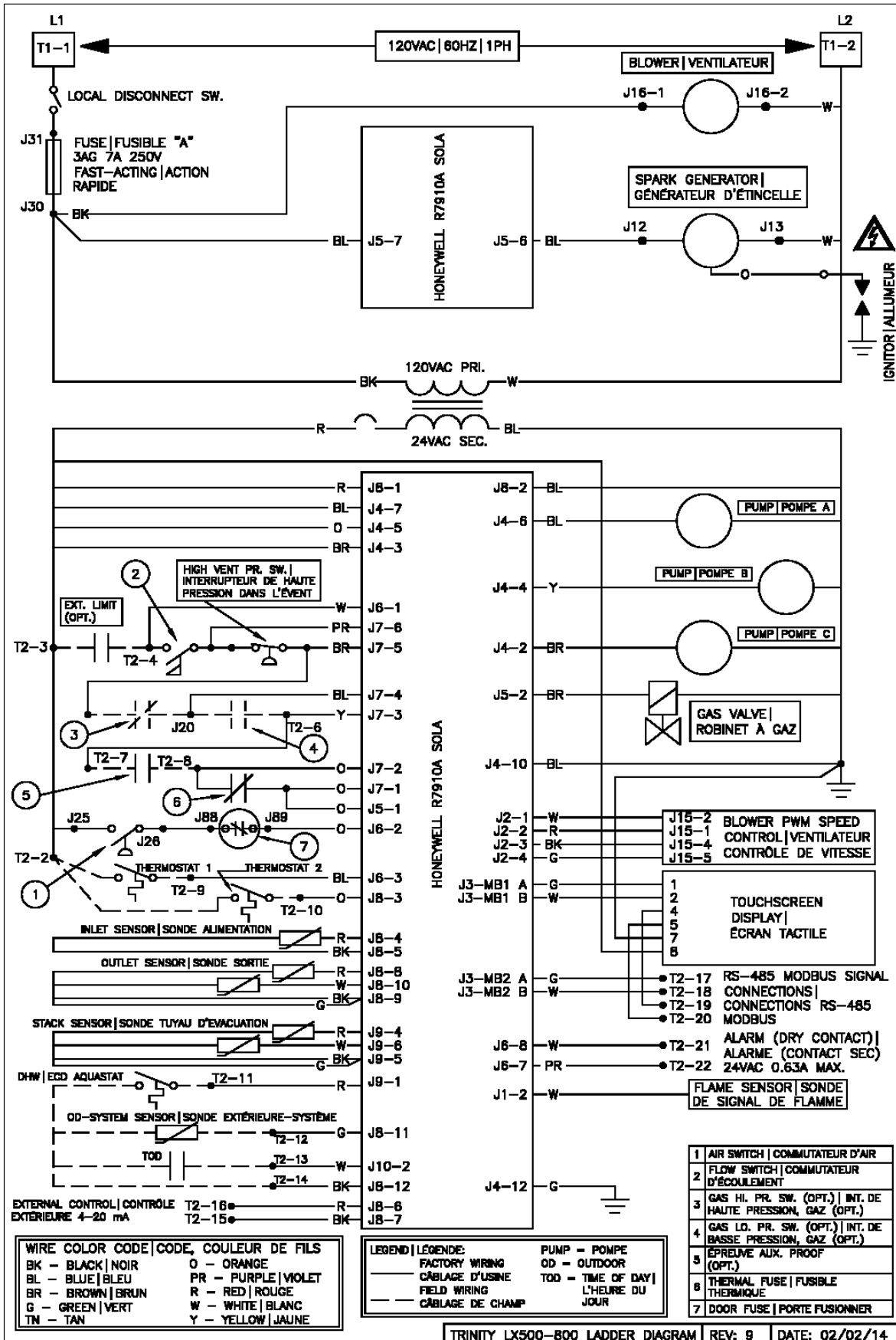

Figure 13-2(b) Ladder/Logic Diagram (US500-800)



14.0 INSTALLATION CHECKLIST

Installation

- 1. If operating on Propane Gas, convert boiler using appropriate Kit number. See Table 7-1.
- 2. Locate the boiler in accordance with Section 3.0 of this manual.
- 3. Install the Vent/Air-inlet piping in accordance with Sections 4.0 and 5.0 of this manual. Ensure all joints are secured and cemented properly. Perform the **Mandatory Pre-commissioning Procedure for Plastic Venting** in Section 4.0.
- 4. Connect the condensate drain in accordance with Section 6.0 of this manual.
- 5. Connect the gas supply in accordance with Section 7.0 of this manual.
- 6. Install the plumbing in accordance with the appropriate this Manual. Flush/cleanse the internals of the heating system. Treat system water with Fernox F1 Protector. See Table 10-1.
- 7. Connect field wiring in accordance with Section 12.0 of this manual.
- 8. Advise home/building owner of their responsibilities with respect to maintaining the boiler.



The building owner is responsible for keeping the Vent/Air-inlet termination free of snow, ice, or other potential blockages and for scheduling routine maintenance on the boiler (see Section 15.0). Failure to properly maintain the boiler may result in serious injury or death.

Start-up



Allow primers/cements to cure for 8 hours prior to Start-up. If curing time is less than 8 hours, first perform Steps 2 through 6 of **Mandatory Pre-commissioning Procedure for Plastic Venting** in Section 4.0. Failure to follow these instructions can result in explosion, serious injury or death.

- 1. Turn gas shut-off valve to the ON position.
- 2. Turn Power on to boiler.
- 3. Set Controller to the desired settings.
- 4. Turn thermostat up, Ignition will occur.

Operational Checklist

- 1. System is free of gas leaks.
- 2. System is free of water leaks.
- 3. Water pressure is maintained above 15 PSI.
- 4. All air is purged from the heating system piping.
- 5. Ensure proper water flow rate; unit must not kettle, bang, hiss or flash the water to steam.
- 6. Ensure gas line pressure is in accordance with Section 9.0.
- 7. System is free of combustion leaks.
- 8. Unit must operate smoothly.
- 9. Ensure the flue gas combustion readings are within the tolerances listed in Table 9-1.
- 10. Each ignition must be smooth.
- 11. Verify that all condensate lines are clean and drain freely.

Before Leaving

- 1. Remove line pressure gauge from gas valve, tighten bleed screw, test screw for leaks. See Section 9.0.
- 2. Install plug into the flue gas test port and test for leaks, see Section 9.0.
- 3. Allow the boiler to complete at least one heating cycle, or to operate for at least 15 minutes.
- 4. Always verify proper operation after servicing.

Instructions to Installing Contractor

- 1. Ensure that the customer receives the Warranty Documentation included with the installation manual.
- 2. Leave the manual with the customer so they know when to call for annual maintenance and inspection.



This boiler must have water flowing through it whenever the burner is firing. Failure to comply may damage the unit, void the warranty, and cause serious injury or death.



Allowing the boiler to operate with a dirty combustion chamber will adversely affect its operation and void the warranty. Failure to clean the heat exchanger on a frequency that matches the need of the application may result in fire, property damage, or death.

15.0 ANNUAL MAINTENANCE AND INSPECTION

This unit must be inspected at the beginning of every heating season by a Qualified Technician.

Annual Inspection Checklist

- 1. Lighting is smooth and consistent, and the combustion fan is noise & vibration free.
- 2. The condensate freely flows from the unit, and is cleaned of sediment.
- 3. Relief Valve and air vents are not weeping.
- 4. Low water cut off is flushed (if applicable)
- 5. Examine all venting for evidence of leaks. Ensure vent screens are cleaned and clear of debris.
- 6. Check the burner plate for signs of leaking.
- 7. The combustion chamber must be inspected and cleaned.
- 8. Listen for water flow noises indicating a drop in boiler water flow rate.
The hydronic system may need to be flushed to eliminate hard water scale
(Use Fernox DS-40 Descaler, ACE PN: ACE83450; see Table 10-1).

Combustion Chamber Cleaning Procedure

Units operating with LP Gas or in an industrial environment will have to be cleaned a minimum of once per year. Other applications will require the combustion chamber to be cleaned after the first year of operation, with subsequent cleanings scheduled based on the condition of the combustion chamber at the time. Unless a step is identified as model specific, the following combustion chamber cleaning procedure is the same for all models.



Crystalline Silica - Read carefully the warnings and handling instructions pertaining to Refractory Ceramic Fibers before commencing any service work in the combustion chamber. Take all necessary precautions and use recommended personal protective equipment as required.

Cleaning Checklist

- 1. Initiate a post-purge cycle to clear any gas from the combustion chamber, then turn gas valve off.
- 2. **Danger Explosion Hazard (US400-800)**: To disconnect the fuel-air metallic tubing between the blower and the high-vent pressure switch, loosen the compression fitting at the high-vent pressure switch with a 1/2" wrench. At the blower end, support the brass fitting body with a 1/2" wrench to keep it from rotating while loosening the compression fitting nut with a 9/16" wrench. Remove tubing assembly from blower.
- 3. Access the combustion chamber by removing the aluminum burner door assembly of the boiler.
- 4. Remove (or cover) the insulation disc located in the back of the combustion chamber to avoid damaging it during the cleaning process. The disc is held in place with a 2.5mm "Allen-head" screw.
- 5. Use a vacuum with a high efficiency filter to remove any loose debris or dust.
- 6. Wet the inside of the combustion chamber with water. Use a garden hose with a trigger nozzle to direct pressurized water through the gaps between the heat exchanger tubes. The water should pass in-between the heat exchanger tubes and exit via the condensate drain. This process may require the use of some dry rags or plastic to protect electrical components from being damaged by dripping or spraying water.
- 7. Use a nylon or other non-metallic brush to loosen the incrustations and any other contaminants that have remained stuck on and in-between the tubes.
- 8. Repeat steps 6 and 7 until the heat exchanger is clean and water from the condensate drain runs clear.
- 9. Re-install the insulation disc to the back of the combustion chamber (see Table 16-1, Item 31 for part #).
- 10. Inspect the insulation disc located on the back-side of the burner door. Replace if damaged (see Table 16-1, Item 33 for part # by applicable model).
- 11. Re-install the burner door, gas-supply and Air-inlet pipe, check for gas leaks.
- 12. **US400-800**: Reconnect the fuel-air metallic tubing between the blower and the high-vent pressure switch. Ensure the brass fitting body at the blower remains stationary and does not rotate during reconnection.
- 13. Perform the Operational Check List detailed in Section 14.0.



Explosion Hazard (US400-800) - The fuel-air metallic tubing connecting the blower and the high-vent pressure switch contains a mixture of fuel and air. Refer to **Combustion Chamber Cleaning Procedure** for instructions on connecting and disconnecting the metallic tubing. Failure to follow these instructions will result in serious injury or death.



Replace any gaskets or insulation discs that show any signs of damage and do not re-use. Failure to follow these instructions may result in fire, property damage or death.

Refractory Ceramic Fibers (RFC)



Personal Protective Equipment Recommended - Read the following warnings and handling instructions carefully before commencing any service work in the combustion chamber. The insulating material on the inside of the burner door and at the back of the combustion chamber contains *Refractory Ceramic Fibers* and should not be handled without personal protective equipment.



Potential Carcinogen - Use of *Refractory Ceramic Fibers* in high temperature applications (above 1000°C) can result in the formation of Crystalline Silica (cristobalite), a respirable silica dust. Repeated airborne exposure to crystalline silica dust may result in chronic lung infections, acute respiratory illness, or death. Crystalline silica is listed as a (potential) occupational carcinogen by the following regulatory organizations: International Agency for Research on Cancer (IARC), Canadian Centre for Occupational Health and Safety (CCOHS), Occupational Safety and Health Administration (OSHA), and National Institute for Occupational Safety and Health (NIOSH). Failure to comply with handling instructions in Table 15-1 may result in serious injury or death.



Crystalline Silica - Certain components confined in the combustion chamber may contain this potential carcinogen. Improper installation, adjustment, alteration, service or maintenance can cause property damage, serious injury (exposure to hazardous materials) or death. Refer to Table 15-1 for handling instruction and recommended personal protective equipment. Installation and service must be performed by a qualified installer, service agency or the gas supplier (who must read and follow the supplied instructions before installing, servicing, or removing this boiler. This boiler contains materials that have been identified as carcinogenic, or possibly carcinogenic, to humans).

Table 15-1 Handling Instructions for Refractory Ceramic Fibers (RCF)

Reduce the Risk of Exposure	Precautions and Recommended Personal Protective Equipment
Avoid contact with skin and eyes	<ul style="list-style-type: none"> Wear long-sleeved clothing, gloves, and safety goggles or glasses.
Avoid breathing in silica dust	<ul style="list-style-type: none"> Wear a respirator with a N95-rated filter efficiency or better. ¹ Use water to reduce airborne dust levels when cleaning the combustion chamber. Do not dry sweep silica dust. Pre-wet or use a vacuum with a high efficiency filter.
Avoid transferring contamination	<ul style="list-style-type: none"> When installing or removing RFCs, place the material in a sealable plastic bag. Remove contaminated clothing after use. Store in sealable container until cleaned. Wash contaminated clothing separately from other laundry.
First Aid Measures	If irritation persists after implementing first aid measures consult a physician. <ul style="list-style-type: none"> Skin - Wash with soap and water. Eyes - Do not rub eyes; flush with water immediately. Inhalation – Breathe in fresh air; drink water, sneeze or cough to clear irritated passage ways.
Notes:	
¹ Respirator recommendations based on CCOHS and OSHA requirements at the time this document was written. Consult your local regulatory authority regarding current requirements for respirators, personal protective equipment, handling, and disposal of RCFs.	

For more information on Refractory Ceramic Fibers, the risks, recommended handling procedures and acceptable disposal practices contact the organization(s) listed below:

Canada (CCOHS): Telephone directory listing under Government Blue Pages Canada—Health and Safety—Canadian Centre for Occupational Health and Safety; or website <http://www.ccohs.ca>.

United States (OSHA): Telephone directory listing under United States Government—Department of Labor—Occupational Safety and Health Administration; or website <http://www.osha.gov>.

16.0 PARTS LIST

For a list of parts that corresponds to the item numbers in the bubbles, refer to Table 16-1. Note that that some item numbers may appear more than once in the parts list depending on which model number is being referenced.

Building Owners - Replacement parts are available from your stocking wholesaler. Contact your local Installer or Wholesaler for assistance with parts.

Wholesalers - Contact NY Thermal Inc. directly when ordering replacement parts, 1-506-657-6000.

Installers - Contact NY Thermal Inc. directly if technical assistance required, 1-800-688-2575.

Figure 16-3 Electrical Housing, Controller, and Display Module (US400)

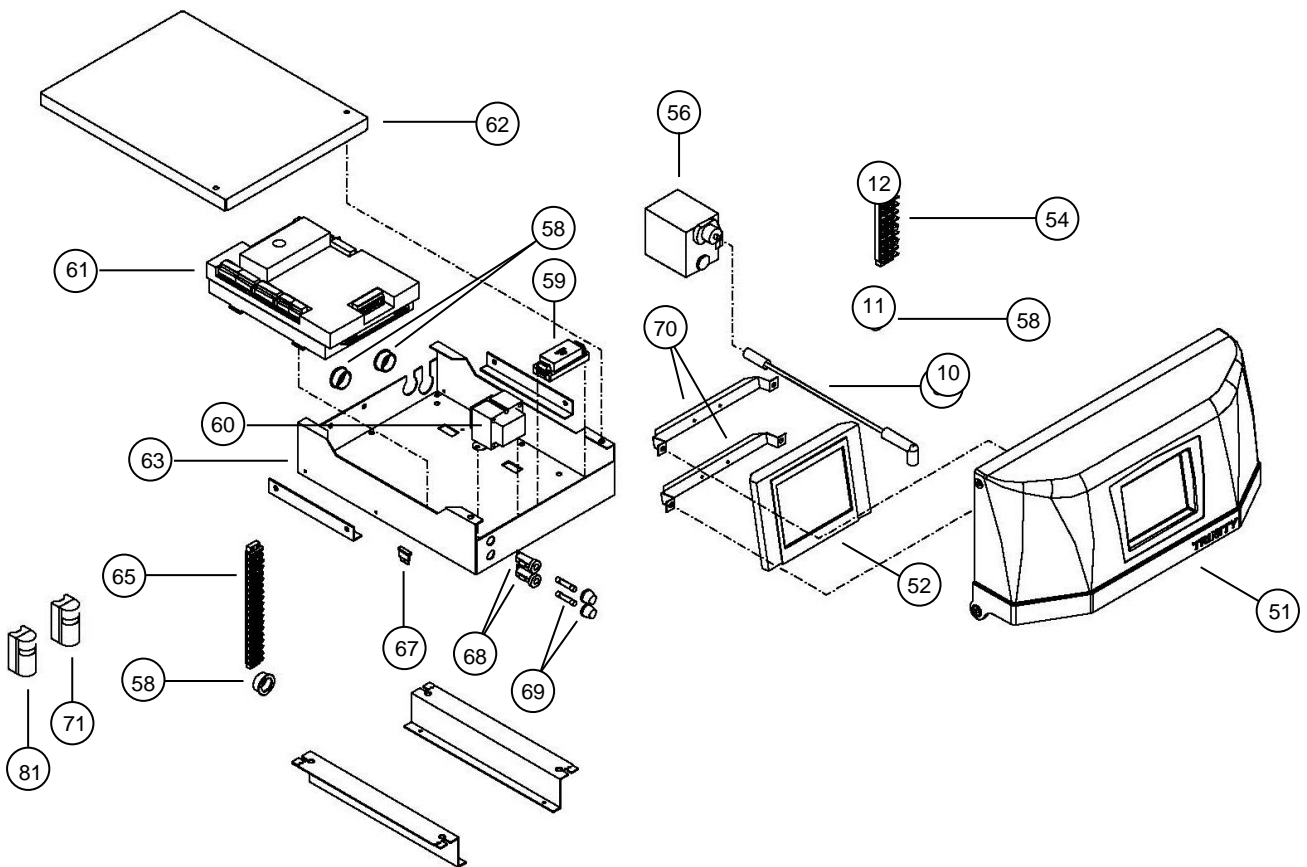

Figure 16-4 Cabinet, Vent and Air-Intake Parts (US400)

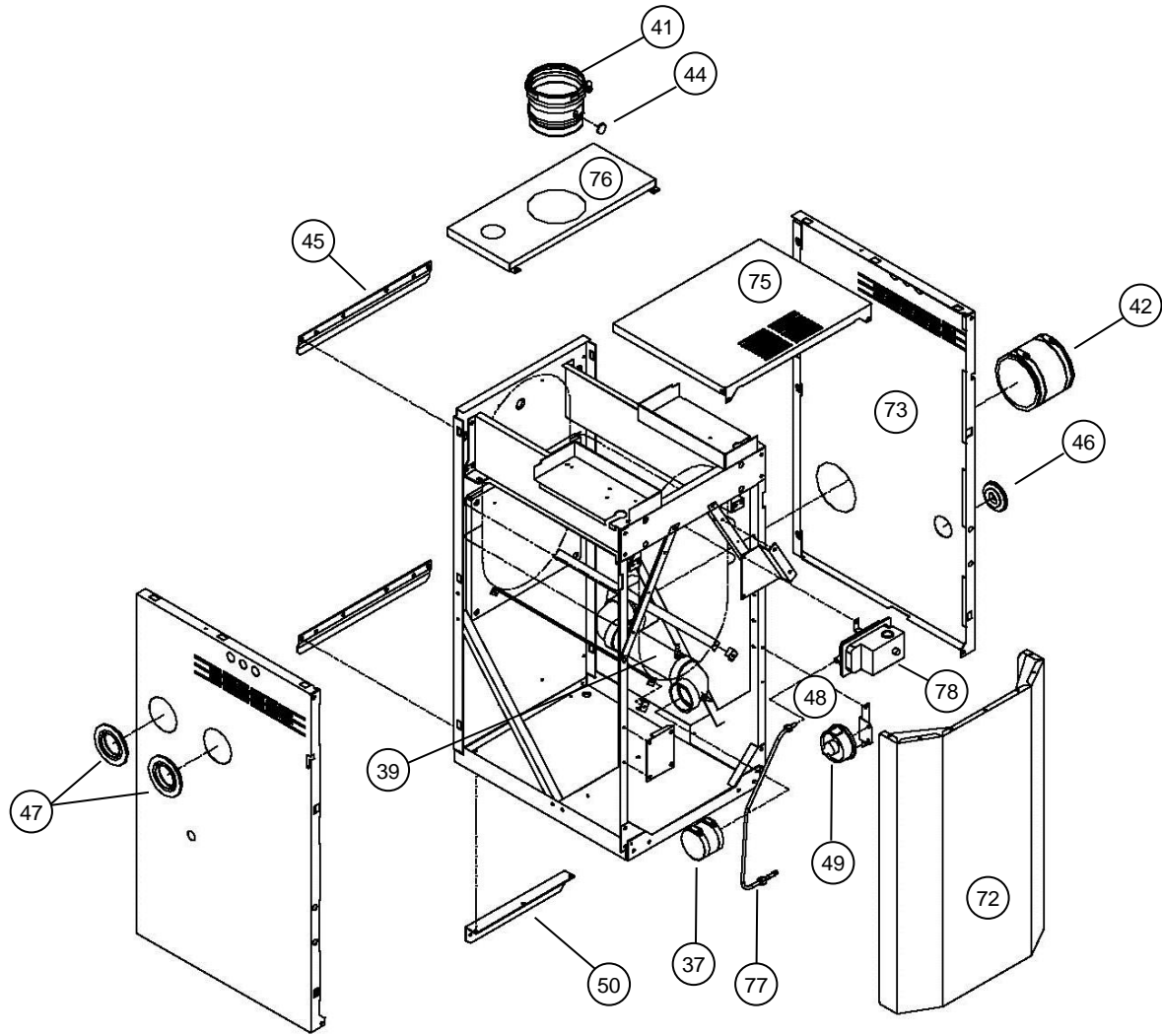
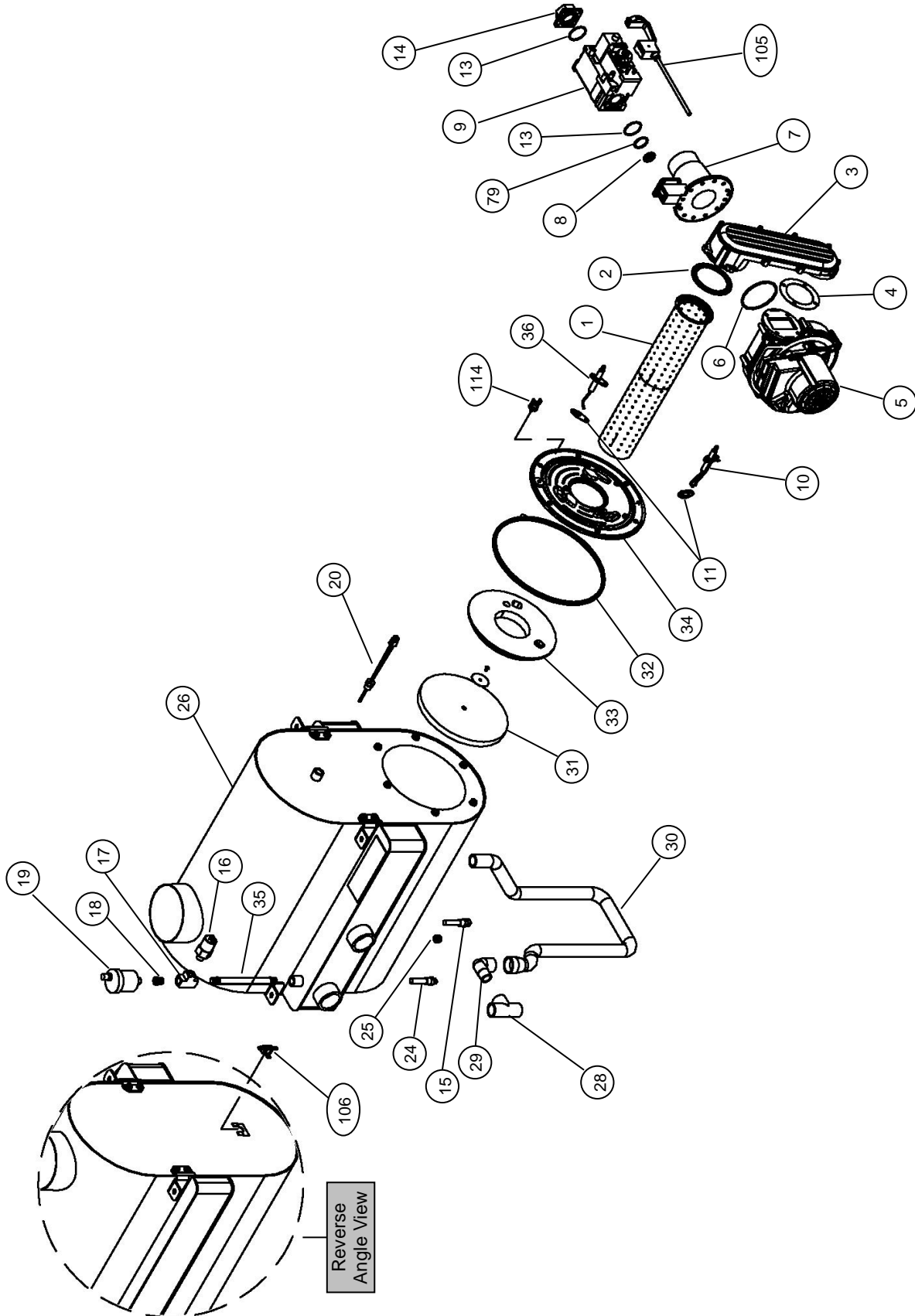

Figure 16-5 Heat Exchanger, Gas Valve, Blower and Burner Assembly (US400)



Commercial Models (US500-800)

Figure 16-6 Cabinet, Vent and Air-inlet Parts (US500-800)

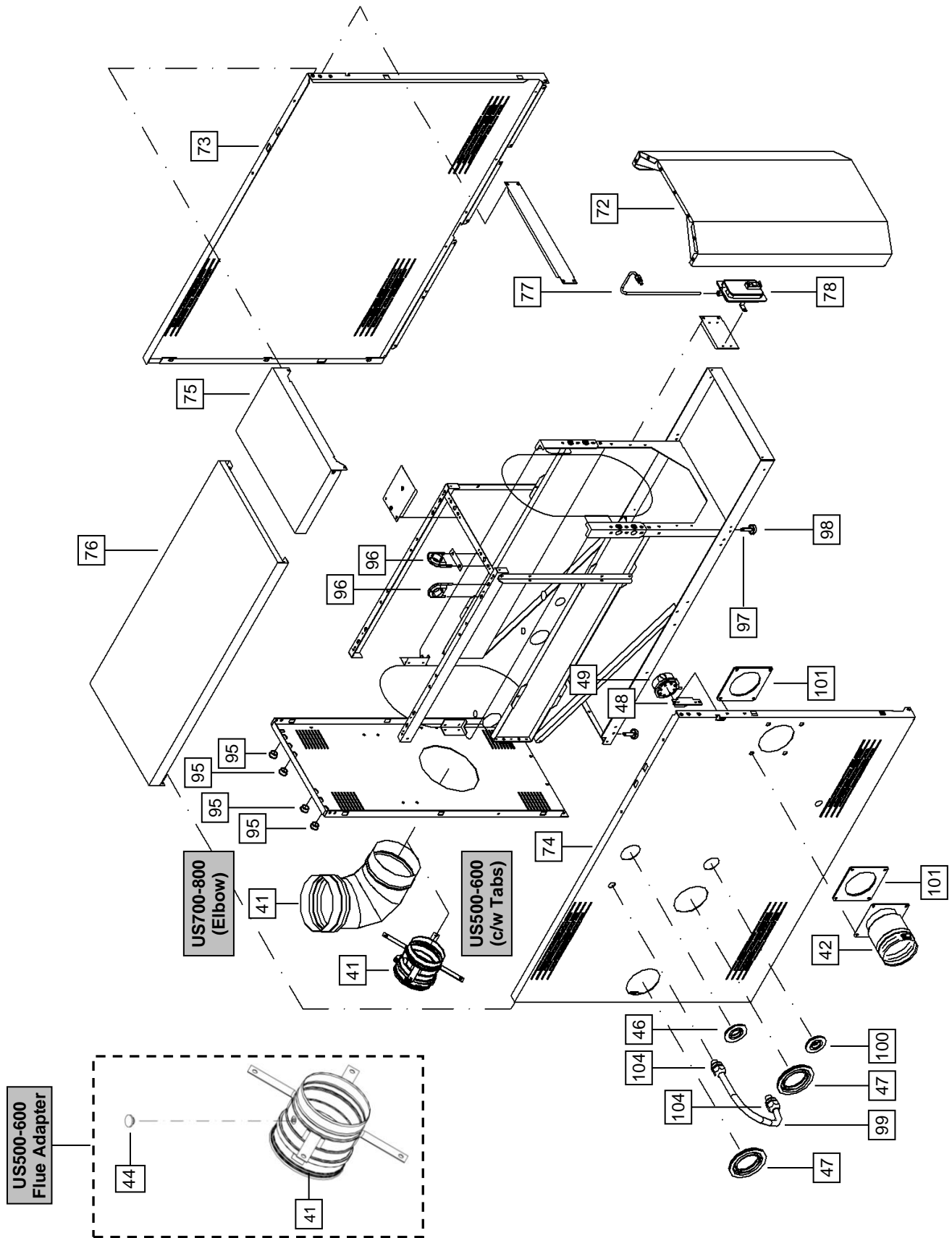

Figure 16-7 Heat Exchanger, Gas Valve, Blower and Burner Assembly (US500)

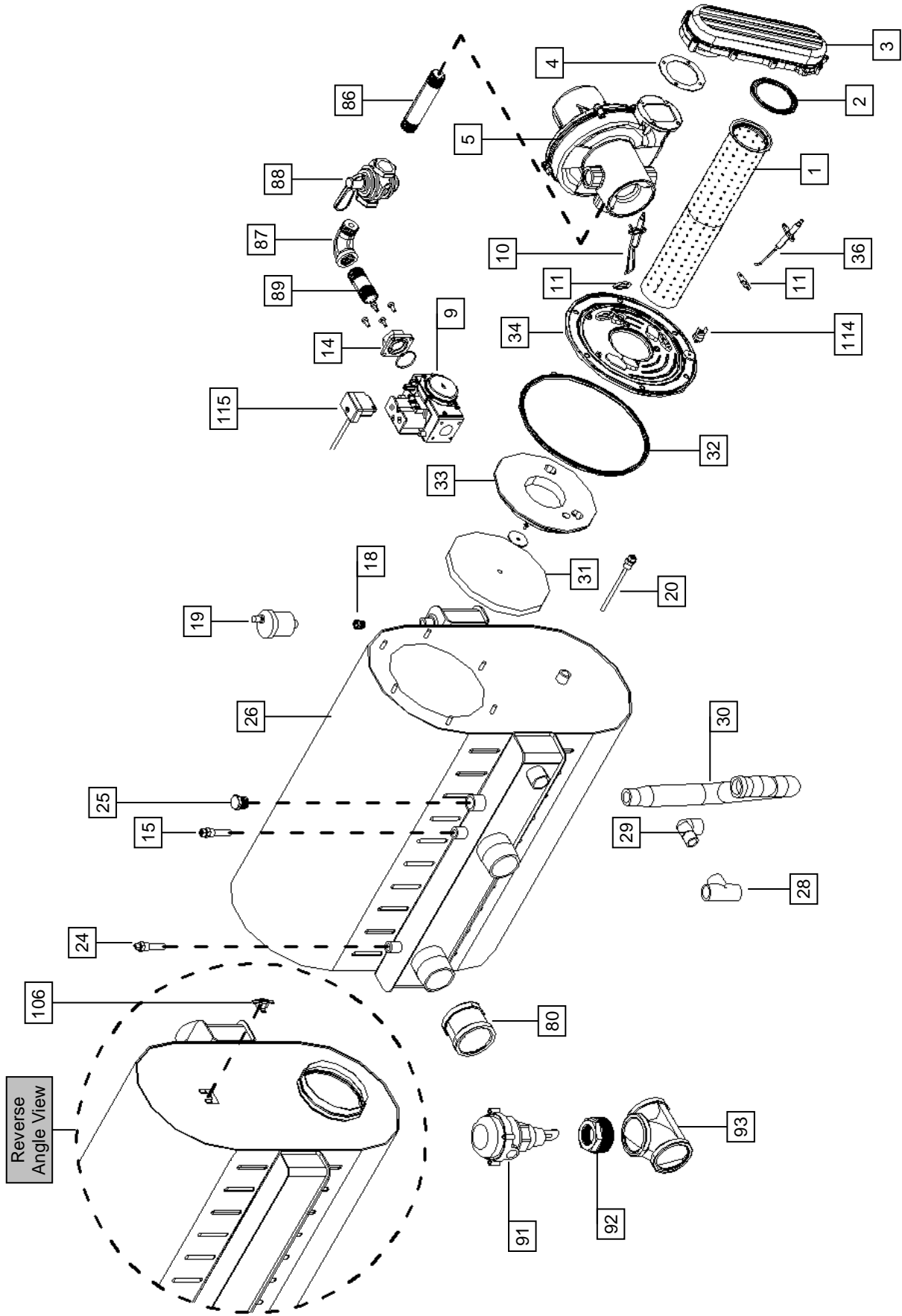

Figure 16-8 Heat Exchanger, Gas Valve, Blower and Burner Assembly (US600-800)

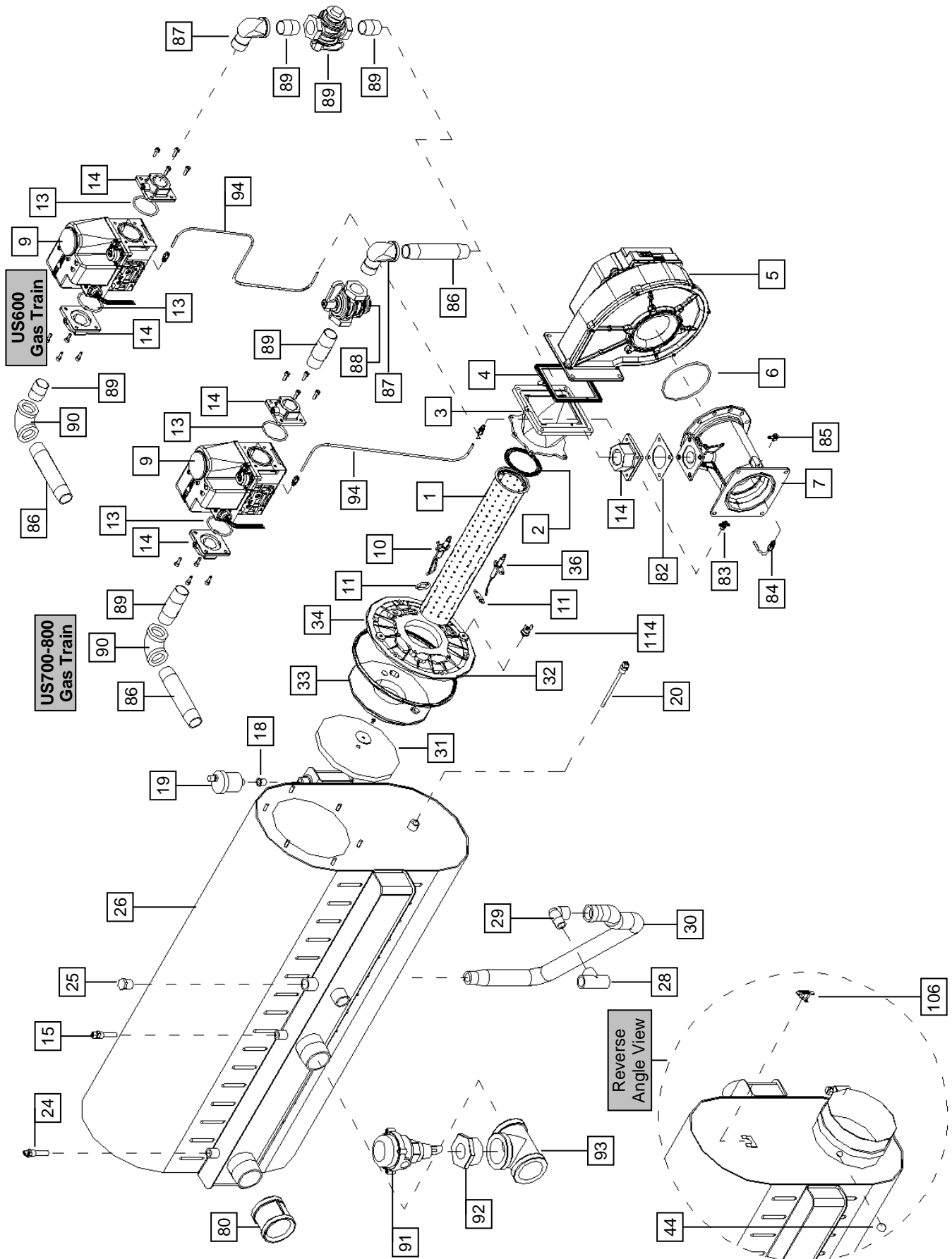

Figure 16-9 Electrical Housing, Controller, and Display Module (US500-800)

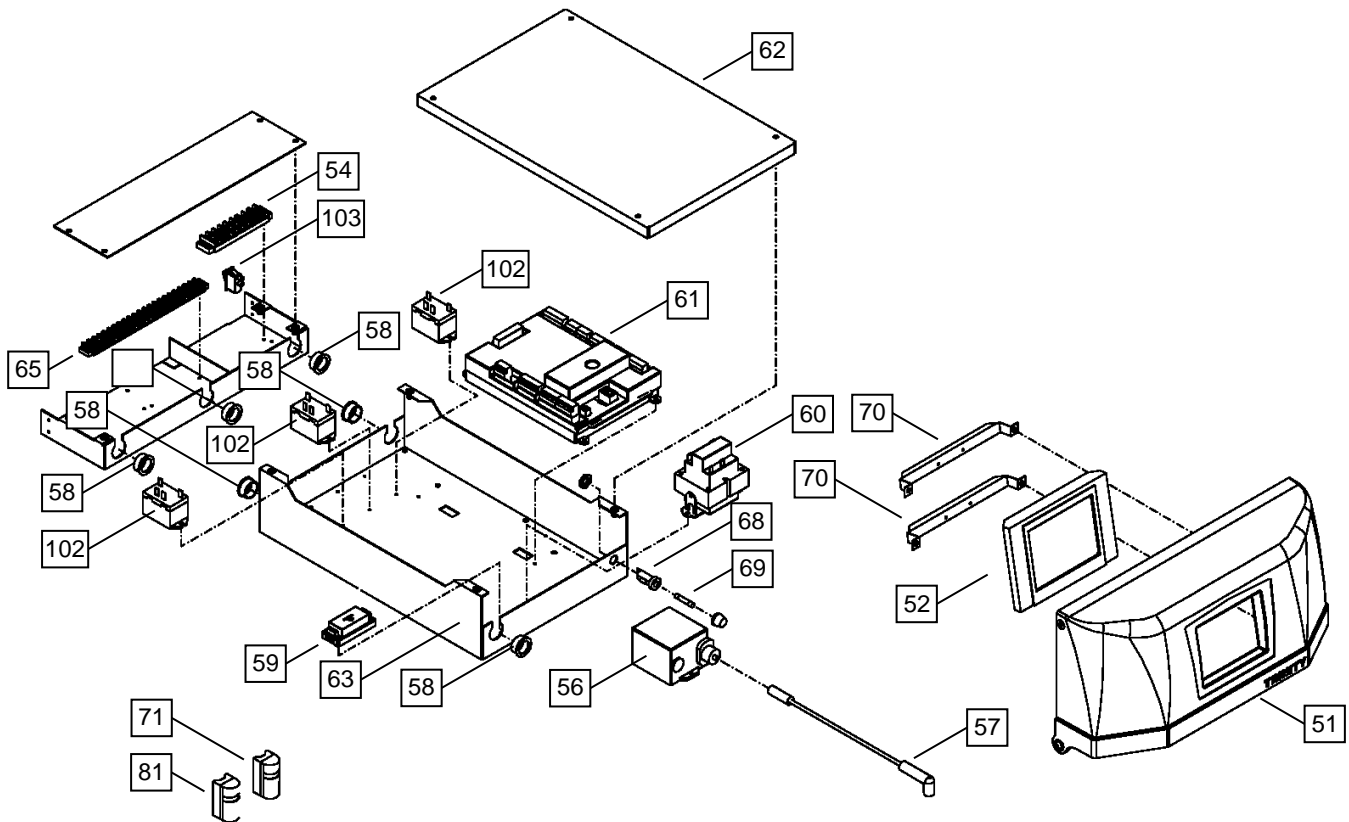

Table 16-1 Parts List: Liberty US

Item	Part #	Models	Description
1	ACE 83338	400, 500	Premix burner (US400-500)
1	ACE 84383	600	Premix burner (US 600)
1	ACE 84134	700, 800	Premix burner (US 700-800)
2	ACE 82761	400-500	Premix Burner Gasket (US 400-500)
2	ACE 84133	600-800	Premix Burner Gasket (US 600-800)
3	ACE 83195	400-500	Extended Air Tube (US 400-500)
3	ACE 84132	600, 700, 800	Conical Air-Gas Inlet Pipe / Stabilor (US 600-800)
4	ACE 82766	400-500	Blower Gasket (US 400-500)
4	ACE 84026	600-800	Blower Gasket (US600-800)
5	ACE 82994	400	EBM Blower RG148/Enhanced (US400)
5	ACE 84322	500	EBM Blower NRG137 (US500)
5	ACE 84006	600-800	EBM Blower G1G170 (US600-800)
6	ACE 83106	400	O-ring, Venturi to Blower (US400)
6	ACE 84084	600-800	O-ring, Venturi to Blower (US600-800)
7	ACE 82990	400	CVI Venturi (US400)
7	ACE 84013	600-800	CVI Venturi (US600-800)
8	ACE 82993	400 (NG)	Gas Valve Orifice, 8.0mm, NG (US400)
8	ACE 83017	400 (LP)	Gas Valve Orifice, 6.2mm, LP (US400)
9	ACE 82989	400	Gas Valve VR8615VB 1044B (US400)
9	ACE 84318	500	Gas Valve GB-ND 057 (US500)
9	ACE 84012	600-800	Gas Valve V8730C 1023B (US600-800)
10	ACE 83870	400-500	Ignition Electrode, Dual - c/w gasket (US400-500)

Item	Part #	Models	Description
10	ACE 84154	600–800	Ignition Electrode, Dual (US600-800)
11	ACE 82774	All Models	Flame Probe Gasket (US Series)
13	ACE 83194	400	Gas Valve Connector O-ring, Large (US400)
13	ACE 84138	600–800	Gas Valve Inlet O-ring (US600-800)
14	ACE 82991	400	Gas Valve Adapter 45900400-138B, 3/4" NPT (US400)
14	ACE 84321	500	Gas Valve Adapter 253-517, 3/4" NPT, c/w screws and O-ring (US500)
14	ACE 84035	600–800	Gas Valve Adapter, 1" NPT (US600-800)
15	ACE 83606	All Models	Outlet Sensor, Dual (US Series)
16	ACE 83223-1	400	Low Water Pressure Switch, 1/4" NPT (US400)
17	ACE 2698	400	1/4" NPT Brass Tee (US400)
18	ACE 83007	All Models	1/4"x 1/8" Bushing Brass (US Series)
19	ACE 82539	All Models	Automatic Air Vent 1/8" (US Series)
20	ACE 83608	400	Flue Sensor, Dual (US400)
20	ACE 84039	500–800	Flue Sensor, Dual (US Commercial)
24	ACE 83605	All Models	Inlet Sensor, Single (US Series)
25	ACE 83706	400	Plug, Brass, 1/4" NPT (US400)
25	ACE 84075	500–800	Plug, Brass, 1/2" NPT (US Commercial)
26	ACE 82926	400	Heat Exchanger-ASME (US400)
26	ACE 84311	500	Heat Exchanger-ASME (US500)
26	ACE 84312	600	Heat Exchanger-ASME (US600)
26	ACE 84005	700, 800	Heat Exchanger-ASME (US700-800)
28	ACE 83721	All Models	Tee, PVC, 1/2", Sch.40, White (US Series)
29	ACE 83720	All Models	Elbow, Street, PVC, 1/2", Sch.40, White (US Series)
30	ACE 83907	400	Condensate Drain Tube (US400)
30	ACE 84313	500, 600	Condensate Drain Tube (US500-600)
30	ACE 83996	700, 800	Condensate Drain Tube (US700-800)
31	ACE 83112	All Models	Liberty US Divider Plate Insulation c/w Washer & Screw (US Series)
32	ACE 82770	400–500	Burner Door Viton Gasket (US400-500)
32	ACE 84136	600–800	Burner Door Viton Gasket (US600-800)
33	ACE 83808	500	Burner Door Ceramic Disc (US500)
33	ACE 83950	400	Burner Door Ceramic Disc (US400)
33	ACE 84137	600–800	Burner Door Ceramic Disc (US600-800)
34	ACE 83885	500	Cast Alum Burner Door (US500)
34	ACE 83949	400	Cast Alum Burner Door (US400)
34	ACE 84135	600–800	Cast Alum Burner Door (US600-800)
35	ACE 83934	400	Nipple, 1/4" x 6", Brass 113-B6 (US400)
36	ACE 82762	400–500	Flame Rod (US400-500)
36	ACE 84155	600–800	Flame Rod (US600-800)
37	ACE 83951	400	2" Gear Clamp Assembly (US400)
39	ACE 83952	400	Air Inlet Assembly (US400)
41	ACE 83213	400	Flue Outlet Adapter (US400)
41	ACE 84387	500, 600	Flue Outlet Adapter c/w Tabs (US500-600)
41	ACE 84052	700, 800	Flue Outlet Adapter (US700-800)
42	ACE 82882	400	Coupling, Rubber, 4", Fernco (US400)
42	ACE 84051	500–800	Air Inlet Adapter SS (US Commercial)
44	ACE 84054	400–800	Exhaust Test Plug (US400-800)
45	ACE 83953	400	Wall Mounting Clip (US400)
46	ACE 83923	400	Grommet, Vinyl, 3/4" IPS (US400)
46	ACE 83506	600–800	Grommet, Vinyl, 1" IPS (1030) (US600-800)
47	ACE 83924	400	Grommet, Vinyl, 2" OD (US400)

Item	Part #	Models	Description
47	ACE 84097	500–800	Grommet, Vinyl, 2 1/2" IPS (3125) (US Commercial)
48	ACE 83954	400	Air Switch Bracket (US400)
48	ACE 84139	600–800	Air Switch Bracket (US600-800)
49	ACE 82662	All Models	Air Switch Huba 604.E021180 set @ .15" w.c. (US Series)
50	ACE 83955	400	Wall Mounting Support, Bottom (US400)
51	ACE 83508	All Models	Display Molding
51	ACE 84622	All Models	Display Molding
54	ACE 83872	All Models	Barrier Strip, Line Voltage (US Series)
56	ACE 83707	All Models	Ignition Coil Q652B1006/B (US Series)
57	ACE 83724	All Models	Spark Igniter Wire, 12" (US Series)
58	ACE 82250	All Models	SNAP BUSHING, 1" (US Series)
59	ACE 83592-1	All Models	Power Supply – Touch Screen (US Series)
60	ACE 83190	400	Transformer, 24V, 40VA (US400)
60	ACE 84047	500–800	Transformer, 24V, 75VA (US Commercial)
61	ACE 83589	400	ICP Honeywell Sola Controller R7910B1015/B (US400)
61	ACE 84034	500–800	ICP Honeywell Sola Controller R7910A1001 (US Commercial)
62	ACE 83878	400	Drawer Cover (US400)
62	ACE 84140	500–800	Control Panel Cover (US Commercial)
63	ACE 83879	400	Drawer (US400)
63	ACE 84141	500–800	Control Panel (US Commercial)
65	ACE 83871	400	Barrier Strip, Low Voltage (US400)
65	ACE 84065	500–800	Barrier Strip, Low Voltage (US Commercial)
67	ACE 83517	400	Fuse, Matrix/US, 2 Amp (US400)
68	ACE 84192	All Models	Fuse Holder, 20 Amp at 250VAC Max (US Series)
69	ACE 83837	All Models	Fuse, Littlefuse 7A, 250VAC, Fast Blow (US Series)
70	ACE 83882	All Models	Touch Screen Display Support (US Series)
71	ACE 81027-1	All Models	Outdoor Sensor, 10K (US Series)
72	ACE 83956	400	Front Cover (US400)
72	ACE 84372	500	Front Cover (US500)
72	ACE 84142	600–800	Front Cover (US600-800)
73	ACE 83957	400	Right Side R1 (US400)
73	ACE 84373	500	Right Side (US500)
73	ACE 84374	600	Right Side (US600)
73	ACE 84143	700, 800	Right Side (US800)
74	ACE 83958	400	Left Side (US400)
74	ACE 84375	500	Left Side (US500)
74	ACE 84376	600	Left Side (US600)
74	ACE 84144	700, 800	Left Side (US700-800)
75	ACE 82959	400	Front Top (US400)
75	ACE 84377	500	Top (US500)
75	ACE 84378	600	Top (US600)
75	ACE 84145	700, 800	Front Top (US700-800)
76	ACE 83960	400	Rear Top (US400)
76	ACE 84146	700, 800	Rear Top (US700-800)
77	ACE 83961	400	Fuel-Air Metallic Tubing with Ends (US400)
77	ACE 84379	500	Fuel-Air Metallic Tubing with Ends (US 500)
77	ACE 84147	600–800	Fuel-Air Metallic Tubing with Ends (US600-800)
78	ACE 83915	400	High-Vent Pressure Switch, AFS460-367 (US400)
78	ACE 84380	500	High -Vent Pressure Switch, ANA124-406 (US500)
78	ACE 84053	600–800	High -Vent Pressure Switch, ANA124-381 (US600-800)

Item	Part #	Models	Description
79	ACE 83962	400	Gas Valve Orifice O-ring, Large (US400)
80	ACE 84057	500-800	Coupling, 2", Brass (US Commercial)
81	ACE 84010	All Models	System Sensor, Pipe Sensor TSA00A4 (US Series)
82	ACE 84087	600-800	Gasket, Cork (US600-800)
83	ACE 84045	600-800	Cross, Brass, M5 Thread To Barb (US600-800)
84	ACE 84148	600-800	Air Metering Tube (US600-800)
85	ACE 84044	600-800	Elbow, Brass, M5 to Barb (US600-800)
86	ACE 84388	500	Nipple, 3/4" x 5", Black Iron (US500)
86	ACE 84061	700, 800	Nipple, 1" x 6", Black Iron (US700-800)
87	ACE 84389	500	Elbow, 3/4", 90 deg., Street, Black Iron (US500)
87	ACE 84063	600-800	Elbow, 1", 90 deg., Street, Black Iron (US600-800)
88	ACE 84347	500	Manual Shutoff Valve, 3/4" NPT (US500)
88	ACE 84025	600-800	Manual Shutoff Valve, 1" NPT (US600-800)
89	ACE 84390	500	Nipple, 3/4" x 2-1/2", Black Iron (US500)
89	ACE 84351	600	Nipple, 1" x Close, Black Iron (US600)
89	ACE 84062	700, 800	Nipple, 1" x 3-1/2", Black Iron (US700-800)
90	ACE 84064	700, 800	Elbow, 1", 90 deg., Black Iron (US700-800)
91	ACE 84102	500-800	Flow switch, FS8-W, Paddles – 2-1/2" (US Commercial)
92	ACE 84099	500-800	Bushing, 2" x 1", Brass (US Commercial)
93	ACE 84058	500-800	Tee, 2" x 2" x 2", Brass (US Commercial)
94	ACE 84381	600	Gas Valve Regulator Sensing Tube (US600)
94	ACE 84149	700, 800	Gas Valve Regulator Sensing Tube (US700-800)
95	ACE 84095	500-800	Plug, 7/8" Black Dome (US Commercial)
96	ACE 84069	600-800	Clamp, U-bolt, 1" IPS (US600-800)
97	ACE 84072	500-800	Leg Leveler, 3/8-16 x 1/5" (US Commercial)
98	ACE 84073	500-800	Leg Leveler Hex Base Cap (US Commercial)
99	ACE 84150	500-800	Flow Switch Wiring Conduit (US Commercial)
100	ACE 83923	500-800	Grommet, Vinyl, 3/4" IPS (1020) (US Commercial)
101	ACE 84346	500	Grommet, Vinyl (3375), Air-inlet (US500)
101	ACE 84011	600-800	Gasket, Air-inlet 3/16" (US600-800)
102	ACE 84056	500-800	Relay, Omron (US Commercial)
103	ACE 84043	500-800	Rocker Switch, Black (US Commercial)
104	ACE 84130	500-800	Flow Switch Wiring Conduit Fitting (US Commercial)
105	ACE 83016	400	Gas Valve Harness (US400)
105	ACE 84319	500	Gas Valve Harness, Dungs (US500)
106	ACE 84392	400-800	Thermal Fuse, Heat Exchanger Exterior (US400-800)
114	ACE 84993	400-800	M5 Reset Safety Switch (US400-800)

17.0 TROUBLESHOOTING

**WARNING**

Observe the following precautions when servicing the boiler. Failure to comply with these may result in fire, property damage, serious injury or death.

Servicing the Boiler

- Disconnect or shut off all energy sources to the boiler: 120VAC power, water and gas.
- Identify and mark wires before disconnecting or removing them.
- Never bypass electrical fuses or limit devices except temporarily for testing.
- Use proper personal protective equipment (PPE) i.e. eye protection, safety footwear.

These procedures should only be performed by qualified service personnel, when abnormal operation of the boiler is suspected. The boiler incorporates a sophisticated microprocessor based control which normally responds appropriately to varying conditions. If the boiler operation appears to be incorrect, or it is not responding at all to a demand for heat, the following is suggested to determine and correct the problem.

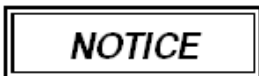
**NOTICE**

Before undertaking any troubleshooting procedures it is highly recommended to have available a digital multimeter(s) capable of measuring AC and DC volts, Amperes, Resistance (ohms) and Continuity.

Check 120VAC and 24VAC at the Boiler

First, verify the following:

- There is 120V being supplied to the boiler:
 - The circuit breaker in the electrical panel supplying power to the boiler is not tripped.
 - The service switch (if applicable) is in the ON position.
- There is a heat call from the thermostat:
 - Verify 24VAC to thermostat.
 - The thermostat is placed at a sufficiently high setting to create a call for heat to the boiler.

To check for the presence of 120VAC and 24VAC at the boiler follow this procedure:

- Remove the boiler front cover.
- 120VAC
 - Remove the Line Voltage junction box cover. First remove the #10 pan-head Phillips screw securing the cover to the junction box. Lift the cover to release it from the boiler base and withdraw the cover from the boiler cabinet. This will expose the Line Voltage barrier strip.
 - With an AC voltmeter set on the appropriate scale, measure the voltage across the L1 and L2 terminals (terminals 1 and 5).
 - If 120VAC is not detected, check the electrical service as suggested above. If the service is verified, inspect the circuit wiring from the panel to the boiler for broken or disconnected conductors.
- 24VAC (only check if 120VAC supply is verified).
 - Remove the Low Voltage junction box cover. First remove the #10 pan-head Phillips screw securing the cover to the junction box. Lift the cover to release it from the boiler base and withdraw the cover from the boiler cabinet. This will expose the Low Voltage barrier strip.
 - With an AC voltmeter set on the appropriate scale, measure the voltage across the R and C terminals (terminals 3 and 1).
 - If 24VAC is not detected, check Fuse "C" (see below).

Figure 17-1(a) US400

Control Panel Fuse Locations

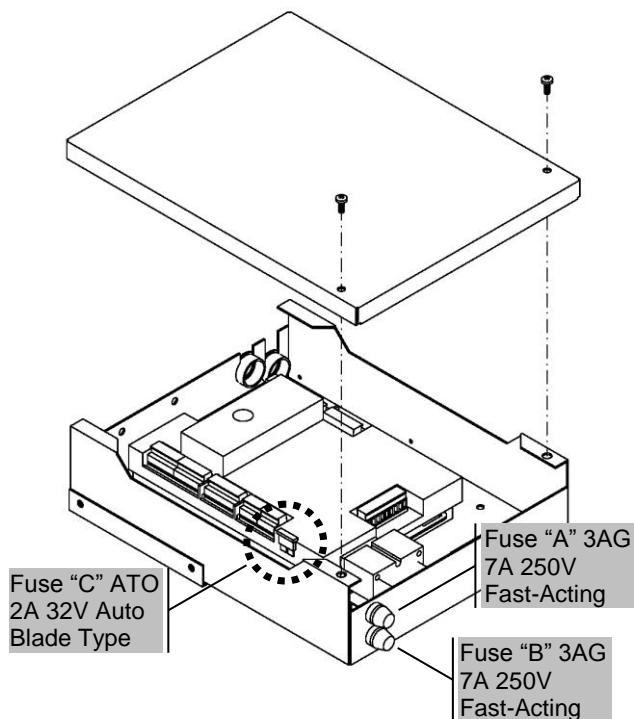
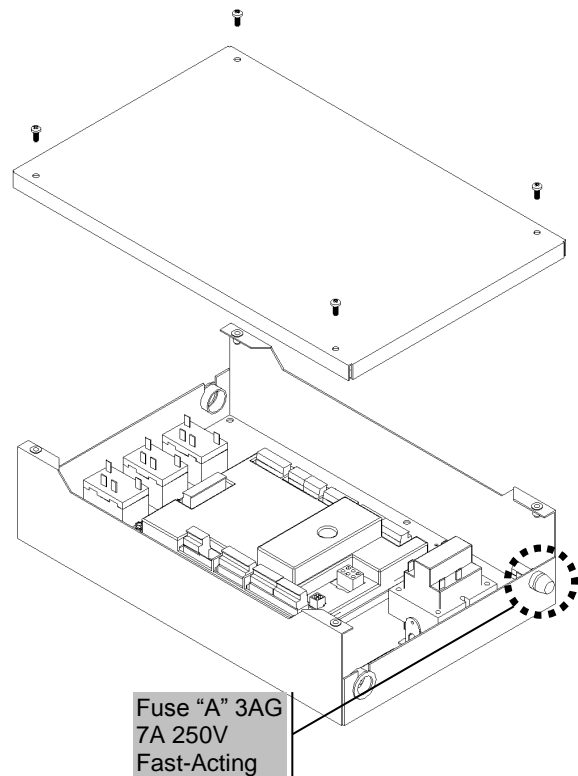

Figure 17-1(b) US500-800

Control Panel Fuse Location



Fuses

There are three (3) fuses associated with the Liberty US-400 controller but only one (1) with the US500-800 controller. Check these fuses before replacing the controller or any other electrical component; if the fuse is blown, it will prevent the protected device(s) from functioning.

To check, and if necessary replace, the fuses:

- Remove all 120VAC power from the boiler. Be careful to check that the unit is not powered from more than one source e.g. a UPS (uninterruptible power supply).
- Remove the front cover.
- On models US400 the control panel is located below the heat exchanger. Fuses "A" and "B" are accessible by removing the spring-loaded knurled knob of their respective holders. Push the knob toward the panel, and twist approximately 1/4 turn counter-clockwise.
- To access Fuse "C", remove the two #10 pan-head Phillips screws and lift the top cover from the panel. The auto blade type fuse is installed in an "inline" style fuse holder.
- On models US500-800, the control panel is located above the heat exchanger toward the back of the unit. Fuse "A" is accessible by removing the spring-loaded knurled knob from its holder. Push the knob toward the panel, and twist approximately 1/4 turn counter-clockwise.

After inspecting and if necessary replacing fuses, replace the panel cover and front cover. Restore power to the boiler and confirm proper operation.



WARNING

Only replace fuses with identical parts, see Figures 17-1(a) and (b). Failure to follow this warning may result in component failure, fire, property damage, serious injury or death.

User Interface (Touch-screen Display)

A blank screen does not necessarily indicate a problem; the display may be configured to automatically blank the screen after a pre-set interval. Simply touch the screen to activate it. Confirm that 120V power is being supplied to the boiler. If the screen does not become active, perform the following procedure:

Blank Screen

1. Remove the front cover from the boiler.
2. Remove the control panel cover and check Fuse “C” (Auto Blade Type); if faulty check for shorts in the thermostat wiring, correct, then replace fuse (see Figure 17-1).
3. Ensure the “2 by 2” Molex connector, located behind the display at the top, is connected and that the wires are fully inserted (see Figure 17-2). Verify that 24VAC is present between the Blue and Red wires; if not trace wiring back to 24VAC transformer; correct wiring and/or replace transformer [see applicable Figure 13-1(a) or 13-2(a)].
4. Remove the display assembly from the control panel and check the 24VAC wiring connection on the back of the display; Blue to terminal 7 [24VAC (COM)], Red to terminal 8 [24VAC].

System Disconnected

If the Touch-screen Display is not blank, but is displaying “System Disconnected!” in the middle of the screen, ensure the 4 by 1 Molex connector, located behind the display at the top, is connected and that the wires are fully inserted (see Figure 17-2). If the connector appears to be fine, check the wiring connections on the back of the touch-screen display; Green, Red and Black go to terminals 1, 2 and 3 respectively.

Figure 17-2 Touch-screen Display Electrical Disconnects

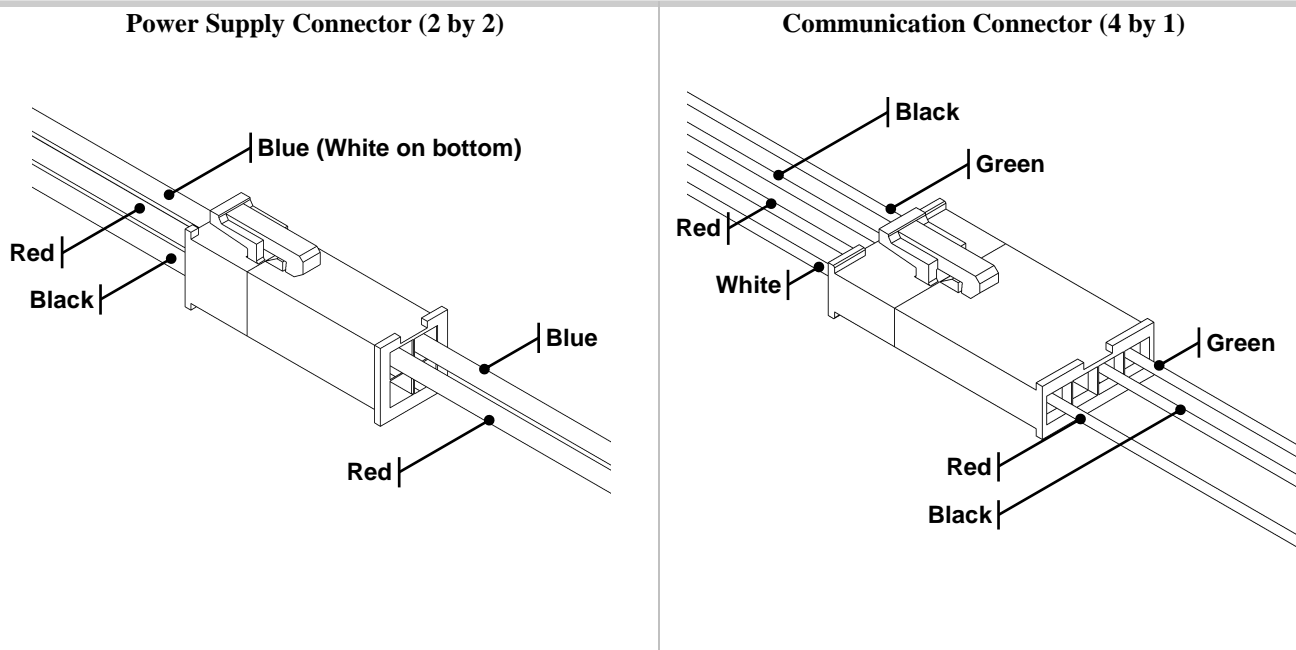

CAUTION

DO NOT drop the plastic housing or allow it to swing down freely, it may be damaged by forceful impact.

Summary and Diagnostics Display – The Liberty US controller and Touchscreen display provides detailed operational and diagnostic information for aid in troubleshooting. When power is applied to the boiler the initial page displayed is the Summary page. Information presented on the Summary page includes Demand source, Burner state, status of sensors and pumps, and so forth. Any current Alert or Lockout condition is also displayed. Accessible from the Summary page are the Diagnostics pages. Refer to the controller manual for more information.

Lockout and Alert History – The controller maintains a record of the fifteen (15) most recent events for both Lockouts and Alerts. To display the logs, touch the History button on the Summary page (refer to Section 7.0 in *Appendix A - Controller and Touchscreen Display Instructions*). In any situation where malfunction is suspected, always check the Alerts and Lockouts history. Entries recorded in the history provide useful information for determining the cause of the malfunction.

Table 17-1 Troubleshooting Chart

PROBLEM	POSSIBLE CAUSE	CORRECTIVE ACTION
Display shows “System Disconnected” constantly	Communication wire disconnected	See, “System Disconnected!” above.
	Faulty Sola controller	If 24VAC present at controller terminals J8 1 & 2, check Power LED on controller. Verify that connector J8 is securely plugged into the controller. Recycle power to boiler, if controller does not operate, replace the controller.
Burner not operating	Heat demand satisfied; no call for heat	Check Demand and Set points via Touchscreen. Check thermostat and DHW aquastat (if applicable) setting.
	Boiler outlet temperature exceeds “Setpoint - On Hysteresis”	Check outlet temperature, setpoint and hysteresis settings via Touchscreen.
	Hold delay or Lockout	Check Summary page on Touchscreen for code.
	Burner switch off	Check Summary page, if Demand indicates “Burner switch off” go to diagnostics burner test page and switch on.
Lockout 2 – Waiting for safety data verification	Safety parameter(s) has been adjusted	Changing settings that are considered safety parameters require “Safety data verification”. Refer to Appendix A.
Lockout 9 – Flame bias out of range	4-20mA input being overdriven.	If using 4-20mA input, check to ensure current is not greater than 21 mA.
	Control malfunction	Cycle power, if problem returns replace control.
Hold 27 – Flame rod shorted to ground detected	A flame circuit shorted to ground may show up as a flame circuit timeout. Zero-ohm shorts can display as Hold 27.	Check to ensure condensate drain is not blocked. Check to ensure no voltage applied to R & T terminals. If using 4-20mA input, check to ensure current is not greater than 21 mA.
Hold 61 – Anti short-cycle	Demand off	Check demand. Delay is to prevent rapid cycling of burner.
Hold 62 – Fan speed not proved	Normal Operation (Drive to Lightoff)	Hold 62 is momentarily displayed prior to burner ignition during the Drive to Lightoff.
	Blown fuse	Check Fuse "A", blown fuse prevents blower from operating.
	Wiring defect	Inspect blower wiring, ensure connectors at Sola controller and blower are securely attached.
	- Faulty Sola controller - Faulty Blower	If Hold 62 persists for 15 seconds or more, while the blower is running, check "Fan speed" indicated on display. If "LOW RPM", "HIGH RPM", "0" or rapidly changing RPM value is displayed, try connecting another Sola controller. If problem remains, replace blower.

Table 17-1 Troubleshooting Chart

PROBLEM	POSSIBLE CAUSE	CORRECTIVE ACTION
Hold 63 – LCI OFF (Limit control input)	Replacement control incorrectly configured.	LCI must be set to “enable” on all US models. See instructions included with replacement controller.
Lockout or Hold 65 – Interrupted Air Switch OFF	No problem, normal operation	Hold 65 will normally be displayed momentarily during the drive to light-off.
	Blown fuse	Check Fuse "A", blown fuse prevents blower from operating.
	Faulty blower	If Fuse “A” is good and blower remains off, check 120VAC supply to blower, if present replace blower. If blower is on proceed to next step.
	Blocked venting	Check for blockage of the exhaust vent.
	Blocked air inlet	Check for blockage of the air inlet.
	Disconnected, damaged or blocked tubing	Inspect the clear vinyl tubing connecting the air switch + and – ports to the air metering elbow. Condensation or other foreign matter may be obstructing the tubing, preventing the switch from sensing differential pressure caused by air flow through the metering elbow.
	Incorrect air switch setting	Contact ACE technical support.
	Faulty air proving switch	If venting and air inlet are clear, temporarily jumper the air switch. If the unit lights and operates smoothly – replace air switch. If the unit fails to light or lights but runs rough or abruptly shuts down – check boiler internals for blockage. WARNING Only jumper the air switch for diagnosing purposes.
	Tripped High Vent Pressure Switch (US400 only)	The high vent pressure switch will trip when the combustion chamber is blocked. Clean combustion chamber and reset switch.
	Tripped Thermal Fuse (US400 only)	Check Thermal Fuse on the back of the heat exchanger (accessed from the rear of the cabinet). If tripped contact ACE.
Tripped Door Reset Safety Switch (US400-800 only)	The Door Reset Safety Switch will trip with the combustion chamber gets dirty or the door insulation fails. Clean the combustion chamber, inspect the door insulation and reset the switch.	
Incorrect air switch wiring	Check that the red and orange wires are connected to quick connect tabs 3 and 1 respectively.	
Hold 66 – Interrupted air switch ON (and blower is off)	Incorrect air switch setting	Contact ACE technical support.
	Incorrect air switch wiring	Check that the red and orange wires are connected to quick connect tabs 3 and 1 respectively.
	Faulty air switch	Disconnect red and orange wires from air switch and check for open circuit between terminals 1 & 3. If continuity detected, replace air switch.
Hold 66 – Interrupted air switch ON (and blower is on)	- Blower problem - Faulty controller	Check low voltage wiring from blower to controller. Check VDC signal from red–green and black-green; if not 28-32VDC and 0 VDC respectfully – replace controller. If signal is correct – replace blower.
Lockout or Hold 67 – ILK OFF	Insufficient water pressure (US400 only)	Ensure at least 15PSI at boiler outlet. Refer to Supplementary Documentation section 2.0 System Piping.

Table 17-1 Troubleshooting Chart

PROBLEM	POSSIBLE CAUSE	CORRECTIVE ACTION
	External Limit Tripped	Indication that an external limit (wired to “LIM”) is open. Not a problem with boiler, check external limit.
	Insufficient flow for Flow Switch (US500-800 only)	Check plumbing, ensure circulator is operating.
	Tripped Thermal Fuse (US500-800 only)	Check Thermal Fuse on the back of the heat exchanger (accessed from the rear of the cabinet). If tripped contact ACE.
	Tripped High Vent Pressure Switch (US500-800 only)	The high vent pressure switch will trip when the combustion chamber is blocked or venting is too restrictive. Check venting and clean combustion chamber.
Lockout or Hold 79 – Outlet High Limit	CH or DHW settings	Check if CH and/or DHW setpoint temperature plus off hysteresis exceed “High limit” setpoint – factory setting = 210°F (99°C).
	CH or DHW pump problem	See "Inoperative CH or DHW pump" below.
	Incorrect “Outlet high limit” setting	Increase “Outlet high limit” setting; maximum setting = 210°F (99°C).
	Incorrect “Outlet high limit response” setting (US400 boiler applications only)	Unless deemed unacceptable by local installation codes, the “Outlet high limit response” should be set to “recycle and hold” to prevent lockout.
Lockout or Hold 81 – Delta T limit OR Boiler making banging or hissing sounds	Insufficient water flow	<ul style="list-style-type: none"> • Check Fuse "A" • Check boiler pump. • Ensure plumbing is correct. Refer to Supplementary Documentation section 2.0 System Piping. Check that water pressure is at least 15PSI. • Boilers Only - Boiler heat transfer surfaces may be fouled with scale or magnetite. Clean with Fernox DS-40 Descaler and Cleanser. See Table 10-1.
Lockout 82 – Stack limit	Dirty heat exchanger	Inspect and if required clean the combustion chamber and/or heat exchanger. Refer to Section 14.0 Annual Maintenance and Inspection and Section 10.0 System Piping.
	Incorrect “Stack limit setpoint”	Unless installed in Canada with PVC exhaust venting, set “Stack limit setpoint” to maximum setting of 220°F (104°C). In Canada PVC exhaust venting is limited to 149°F (65°C).
	Faulty sensor	Check resistance of stack sensor and compare to thermistor resistance chart, see Table 17-2.
Lockout or Hold 85 – Inlet/Outlet Inversion Limit	Pump flowing in the wrong direction	Ensure water circulation is flowing into the boiler at the fitting closest to the wall.
	Incorrect factory sensor wiring	Disconnect flue sensor cable; screen should display “Hold 95 – Stack sensor fault”; if not contact ACE.
Lockout or Hold 88 – Outlet T Rise limit	Insufficient water flow	See Lockout or Hold 81.
Hold 91– Inlet sensor fault	Sensor disconnected	<ul style="list-style-type: none"> • Verify that 2-position Molex connector on wiring harness is securely attached to mating connector on inlet sensor. • Inspect sensor wiring.

Table 17-1 Troubleshooting Chart

PROBLEM	POSSIBLE CAUSE	CORRECTIVE ACTION
	Faulty sensor	Check resistance of sensor and compare to thermistor resistance chart, see Table 17-2.
Hold 92 – Outlet sensor fault	Sensor disconnected	<ul style="list-style-type: none"> • Verify that 4-position Molex connector on wiring harness is securely attached to mating connector on outlet sensor. • Inspect sensor wiring.
	Faulty sensor	Check resistance of sensor and compare to thermistor resistance chart, see Table 17-2.
Hold 95 – Stack sensor fault	Sensor disconnected	<ul style="list-style-type: none"> • Verify that 4-position Molex connector on wiring harness is securely attached to mating connector on stack sensor. • Inspect sensor wiring.
	Faulty sensor	Check resistance of sensor and compare to thermistor resistance chart, see Table 17-2.
Lockout 109 – Ignition failure occurred (US500-800 only) Or Hold 110 – Ignition failure occurred, failure to prove flame after 3 ignition attempts (US400 only)	Spark cable disconnected	Ensure that the high voltage spark cable is securely connected to the spark generator and the igniter electrode. Check that the green ground wire is securely attached to the ¼” quick connect tab on the igniter electrode.
	Insufficient gas line pressure	Ensure the manual gas shutoff valve is open. Refer to manual section 9.0 GAS VALVE AND BURNER SETUP.
	Flame rod disconnected	Verify that the flame rod signal wire is securely attached to the flame rod, which is located bottom center of the burner door.
	No 120VAC to Spark Generator	Check wiring from controller to spark generator. With an AC voltmeter measure voltage across J5-6 and ground (the controller chassis is connected to the 120VAC supply ground) during trial for ignition.
	Faulty Spark Generator	During trial for ignition check for arc on spark electrode via the observation port located next to the spark electrode in the burner door. If the spark generator is receiving 120VAC and no spark is observed, replace the spark generator.
	No 24VAC to Gas Valve	Check the wiring harness for loose or interrupted connections of the gas valve wiring. With an AC voltmeter, measure the voltage from controller terminals J5-2 to J4-10. There should be 24VAC present during trial for ignition.
	Faulty Gas Valve	The gas valve emits an audible click when it switches on or off. If the controller is providing 24VAC to the gas valve, and the wiring is intact, it should be possible to detect if the valve is responding.
Lockout 113 – Flame circuit timeout	A flame circuit shorted to ground may show up as a flame circuit timeout. High resistance shorts can display as Lockout 113.	Check to ensure condensate drain is not blocked. Check to ensure no voltage applied to R & CH terminals. If using 4-20mA input, check to ensure current is not greater than 21mA.
Lockout 122 – Lightoff rate proving failed	Blower is not turning on	See “Blower not operating” below.
	Missing or incorrect blower feedback signal	See Hold 62 above.

Table 17-1 Troubleshooting Chart

PROBLEM	POSSIBLE CAUSE	CORRECTIVE ACTION
	Blower is always on	See “Blower operating at high speed while burner is off” below.
Alert 128 - Modulation rate was limited due to IAS was open (Air switch open while burner firing)	Blocked venting	Check for blockage of the exhaust vent.
	Blocked air inlet	Check for blockage of the air inlet.
Lockout 173 - Pilot relay feedback incorrect Lockout 174 – Safety relay feedback incorrect	External Electrical Noise	Look for sources of electrical noise, i.e. a large motor or multiple pieces of equipment starting at the same time.
	Failing Limit Switch in ILK circuit	Check operation of internal LWCO, and/or external limit (i.e. device connected between “R” and “LIM”); replace as necessary
	Hardware failure of Sola controller	Reset power, If problem persists replace Sola controller.
Alert 206 – Lead Lag header temperature was invalid	System Sensor not connected	If desired, install System Sensor and wire to sensor input connections “SYSTEM” and “SENSOR COM”. Otherwise ignore Alert 206
Alert 233 – Lead Lag outdoor temperature was invalid	See Alert 248	
Alert 248 – CH outdoor temperature was invalid	Outdoor sensor not connected	The Liberty US is factory set with Outdoor Reset enabled. Connect outdoor sensor or disable Outdoor Reset.
	Outdoor sensor wiring	Check wiring of outdoor sensor. Wires should connect to Low Voltage barrier terminals 11 & 12.
	Faulty sensor	Check sensor. Should be free of ice and snow. Check resistance of sensor and compare to thermistor resistance chart, see Table 17-2.
Alert 311 – Run was terminated due to interrupted air flow switch was off	Blocked venting	Check for blockage of the exhaust vent.
	Blocked air inlet	Check for blockage of the air inlet.
	Disconnected, damaged or blocked tubing	Inspect the clear vinyl tubing connecting the air switch + and – ports to the air metering elbow. Condensation or other foreign matter may be obstructing the tubing, preventing the switch from sensing differential pressure caused by air flow through the metering elbow.
	Incorrect air switch setting	Contact ACE technical support.
	Blown fuse	Check Fuse "A".
Inoperative CH and/or DHW pump	Blown fuse	Check Fuse "B".
	Faulty controller	If Fuse “B” not blown, and controller is operating, navigate to pump diagnostic on display. Manually switch pump on, check for 120VAC at pump connection terminal on line voltage barrier strip. If 120VAC not detected, replace controller.
	Faulty pump	If 120VAC supplied to pump, and pump does not operate, replace pump.
Blower operating at high speed while burner off	Blower signal cable disconnected	<ul style="list-style-type: none"> Verify that the 5-position Molex connector on the wiring harness is securely connected to its mating connector on the blower. Check that the 4-position Molex connector on wiring harness is securely connected to its mating connector on the controller.

Table 17-1 Troubleshooting Chart

PROBLEM	POSSIBLE CAUSE	CORRECTIVE ACTION
Blower operating at high speed while burner off	No 24VAC to controller	<ul style="list-style-type: none"> • Check Power LED on controller. • Check Fuse "C". • With an AC voltmeter measure voltage at terminals J8 1 & 2, 24VAC should be present.
Blower not operating	Blower power disconnected	Verify that the 3-position Molex connector on the wiring harness is securely connected to its mating connector on the blower.
	Blown fuse	Check Fuse "A" using the procedure described above. Fuse "A" protects the blower as well as the ignition spark generator and boiler pump.
	Faulty blower	Measure voltage across pins 1 & 2 (black and white wires) of 3-position connector on wiring harness. If 120VAC detected, replace power connector and remove 5-position signal connector. Blower should rotate at high speed. If blower does not rotate, replace blower.

Table 17-2 Thermistor Resistance vs. Temperature

Temp °F (°C)	Resistance Ohms (Ω)	Temp °F (°C)	Resistance Ohms (Ω)
-22 (-30)	176,133	122 (50)	3,603
-4 (-20)	96,761	131 (55)	2,986
14 (-10)	55,218	140 (60)	2,488
32 (0)	32,650	149 (65)	2,083
41 (5)	25,390	158 (70)	1,752
50 (10)	19,900	167 (75)	1,481
59 (15)	15,710	176 (80)	1,258
68 (20)	12,490	185 (85)	1,072
77 (25)	10,000	194 (90)	918
86 (30)	8,057	203 (95)	789
95 (35)	6,531	212 (100)	680
104 (40)	5,327	230 (110)	506
113 (45)	4,369	-	-

Table 17-3 Hold and Lockout Codes

Code	Description	Note
0	None	Hold / No lockout
1	Unconfigured safety data	Lockout
2	Waiting for safety data verification	Lockout
3	Internal fault: Hardware fault	Hold
4	Internal fault: Safety Relay key feedback error	Hold
5	Internal fault: Unstable power (DCDC) output	Hold
6	Internal fault: Invalid processor clock	Hold
7	Internal fault: Safety relay drive error	Hold
8	Internal fault: Zero crossing not detected	Hold
9	Internal fault: Flame bias out of range	Hold
10	Internal fault: Invalid Burner control state	Lockout
11	Internal fault: Invalid Burner control state flag	Lockout
12	Internal fault: Safety relay drive cap short	Hold

Table 17-3 Hold and Lockout Codes

Code	Description	Note
13	Internal fault: PII shorted to ILK	Hold / Lockout
14	Internal fault: HFS shorted to LCI	Hold / Lockout
15	Internal fault: Safety relay test failed due to feedback ON	Lockout
16	Internal fault: Safety relay test failed due to safety relay OFF	Lockout
17	Internal fault: Safety relay test failed due to safety relay not OFF	Lockout
18	Internal fault: Safety relay test failed due to feedback not ON	Lockout
19	Internal fault: Safety RAM write	Lockout
20	Internal fault: Flame ripple and overflow	Hold
21	Internal fault: Flame number of sample mismatch	Hold
22	Internal fault: Flame bias out of range	Hold
23	Internal fault: Bias changed since heating cycle starts	Hold
24	Internal fault: Spark voltage stuck low or high	Hold
25	Internal fault: Spark voltage changed too much during flame sensing time	Hold
26	Internal fault: Static flame ripple	Hold
27	Internal fault: Flame rod shorted to ground detected	Hold
28	Internal fault: A/D linearity test fails	Hold
29	Internal fault: Flame bias cannot be set in range	Hold
30	Internal fault: Flame bias shorted to adjacent pin	Hold
31	Internal fault: SLO electronics unknown error	Hold
32	Internal fault: Safety Key 0	Lockout
33	Internal fault: Safety Key 1	Lockout
34	Internal fault: Safety Key 2	Lockout
35	Internal fault: Safety Key 3	Lockout
36	Internal fault: Safety Key 4	Lockout
37	Internal fault: Safety Key 5	Lockout
38	Internal fault: Safety Key 6	Lockout
39	Internal fault: Safety Key 7	Lockout
40	Internal fault: Safety Key 8	Lockout
41	Internal fault: Safety Key 9	Lockout
42	Internal fault: Safety Key 10	Lockout
43	Internal fault: Safety Key 11	Lockout
44	Internal fault: Safety Key 12	Lockout
45	Internal fault: Safety Key 13	Lockout
46	Internal fault: Safety Key 14	Lockout
47	Flame rod to ground leakage	Hold
48	Static flame (not flickering)	Hold
49	24VAC voltage low/high	Hold
50	Modulation fault	Hold
51	Pump fault	Hold
52	Motor tachometer fault	Hold
53	AC inputs phase reversed	Lockout
54	Safety GVT model ID doesn't match application's model ID	Lockout
55	Application configuration data block CRC errors	Lockout
56-57	RESERVED	
58	Internal fault: HFS shorted to IAS	Lockout
59	Internal fault: Mux pin shorted	Lockout
60	Internal fault: HFS shorted to LFS	Lockout
61	Anti short cycle	Hold
62	Fan speed not proved	Hold

Table 17-3 Hold and Lockout Codes

Code	Description	Note
63	LCI OFF	Hold
64	PII OFF	N/A
65	Interrupted Airflow Switch OFF	Hold
66	Interrupted Airflow Switch ON	Hold
67	ILK OFF	Hold
68	ILK ON	N/A
69	Pilot test hold	Hold
70	Wait for leakage test completion	Hold
71	Input power frequency mismatch	Lockout
72-77	RESERVED	
78	Demand lost in run	Hold
79	Outlet high limit	Hold
80	DHW high limit	Disabled
81	Delta T limit	Hold / Lockout
82	Stack limit	Lockout
83	Delta T exchanger/outlet limit	Disabled
84	Delta T inlet/exchanger limit	Disabled
85	Inlet/Outlet inversion limit (See Table 17-1)	Hold
86	Exchanger/outlet inversion limit	Disabled
87	Inlet/exchanger inversion limit	Disabled
88	Outlet T-Rise limit (See Table 17-1)	Lockout
89	Exchanger T-rise limit	Disabled
90	Heat exchanger high limit	Disabled
91	Inlet sensor fault	Hold
92	Outlet sensor fault	Hold
93	DHW sensor fault	Hold
94	Header sensor fault	Hold
95	Stack sensor fault	Hold
96	Outdoor sensor fault	Hold
97	Internal fault: A2D mismatch	Lockout
98	Internal fault: Exceeded VSNSR voltage tolerance	Lockout
99	Internal fault: Exceeded 28V voltage tolerance	Lockout
100	Pressure sensor fault	Hold
101	Exchanger sensor fault	Disabled
102-104	RESERVED	
105	Flame detected out of sequence	Hold / Lockout
106	Flame lost in MFEP	Lockout
107	Flame lost early in run	Lockout
108	Flame lost in run	Lockout
109	Ignition failed	Lockout
110	Ignition failure occurred	Hold
111	Flame current lower than WEAK threshold	Hold
112	Pilot test flame timeout	Lockout
113	Flame circuit timeout	Lockout
114-115	RESERVED	
116	Wait for OK to Run	Disabled
117	Flap valve condensate fault	Disabled
118	Controller interaction system fault	Hold
119	Controller interaction communications fault	Hold

Table 17-3 Hold and Lockout Codes

Code	Description	Note
120	Flap valve backflow fault	Disabled
121	Flap valve fault	Disabled
122	Light off rate proving failed	Lockout
123	Purge rate proving failed	Lockout
124	High fire switch OFF	Hold
125	High fire switch stuck ON	Hold
126	Low fire switch OFF	Hold
127	Low fire switch stuck ON	Hold
128	Fan speed failed during pre-purge	Hold / Lockout
129	Fan speed failed during pre-ignition	Hold / Lockout
130	Fan speed failed during ignition	Hold / Lockout
131	Fan movement detected during standby	Hold
132	Fan speed failed during run	Hold
133-135	RESERVED	
136	Interrupted Airflow Switch failed to close	Hold
137	ILK failed to close	Hold
138	Flame too low	Lockout
139-142	RESERVED	
143	Internal fault: Flame bias out of range 1	Lockout
144	Internal fault: Flame bias out of range 2	Lockout
145	Internal fault: Flame bias out of range 3	Lockout
146	Internal fault: Flame bias out of range 4	Lockout
147	Internal fault: Flame bias out of range 5	Lockout
148	Internal fault: Flame bias out of range 6	Lockout
149	Flame detected	Hold / Lockout
150	Flame not detected	Hold
151	High fire switch ON	Hold / Lockout
152	Combustion pressure ON	Hold / Lockout
153	Combustion pressure OFF	Hold / Lockout
154	Purge fan switch ON	Hold / Lockout
155	Purge fan switch OFF	Hold / Lockout
156	Combustion pressure and Flame ON	Hold / Lockout
157	Combustion pressure and Flame OFF	Lockout
158	Main valve ON	Lockout
159	Main valve OFF	Lockout
160	Ignition ON	Lockout
161	Ignition OFF	Lockout
162	Pilot valve ON	Lockout
163	Pilot valve OFF	Lockout
164	Block intake ON	Lockout
165	Block intake OFF	Lockout
166-168	RESERVED	
169	Safety opto bad in test state	Lockout
170	Safety relay opto feedback incorrect	Lockout
171	Safety relay feedback incorrect in run	Lockout
172	Main relay feedback incorrect	Lockout
173	Pilot relay feedback incorrect	Lockout
174	Safety relay feedback incorrect	Lockout
175	Safety relay open	Lockout

Table 17-3 Hold and Lockout Codes

Code	Description	Note
176	Main relay ON at safe start check	Lockout
177	Pilot relay ON at safe start check	Lockout
178	Safety relay ON at safe start check	Lockout
179-180	RESERVED	
181	Invalid Blocked condensate enable setting	Disabled
182	Invalid J7-1 configuration, both LFS and Blocked condensate	Disabled
183	Invalid J7-2 configuration, both HFS and Flap valve	Disabled
184	Invalid BLOWER/HSI output setting	Lockout
185	Invalid Delta T limit enable setting	Lockout
186	Invalid Delta T limit response setting	Lockout
187	Invalid DHW high limit enable setting	Lockout
188	Invalid DHW high limit response setting	Lockout
189	Invalid Flame sensor type setting	Lockout
190	Invalid interrupted air switch enable setting	Lockout
191	Invalid interrupted air switch start check enable setting	Lockout
192	Invalid Igniter on during setting	Lockout
193	Invalid Ignite failure delay setting	Lockout
194	Invalid Ignite failure response setting	Lockout
195	Invalid Ignite failure retries setting	Lockout
196	Invalid Ignition source setting	Lockout
197	Invalid Interlock open response setting	Lockout
198	Invalid Interlock start check setting	Lockout
199	Invalid LCI enable setting	Lockout
200	Invalid light off rate setting	Lockout
201	Invalid Light off rate proving setting	Lockout
202	Invalid Main Flame Establishing Period time setting	Lockout
203	Invalid MFEP flame failure response setting	Lockout
204	Invalid NTC sensor type setting	Lockout
205	Invalid Outlet high limit response setting	Lockout
206	Invalid Pilot Flame Establishing Period setting	Lockout
207	Invalid PII enable setting	Lockout
208	Invalid pilot test hold setting	Lockout
209	Invalid Pilot type setting	Lockout
210	Invalid Post-purge time setting	Lockout
211	Invalid Power up with lockout setting	Lockout
212	Invalid Pre-ignition time setting	Lockout
213	Invalid Pre-purge rate setting	Lockout
214	Invalid Pre-purge time setting	Lockout
215	Invalid Purge rate proving setting	Lockout
216	Invalid Run flame failure response setting	Lockout
217	Invalid Run stabilization time setting	Lockout
218	Invalid Stack limit enable setting	Lockout
219	Invalid Stack limit response setting	Lockout
220	Unconfigured Delta T limit set point setting	Lockout
221	Unconfigured DHW high limit set point setting	Lockout
222	Unconfigured Outlet high limit set point setting	Lockout
223	Unconfigured Stack limit set point setting	Lockout
224	Invalid DHW demand source setting	Lockout
225	Invalid Flame threshold setting	Lockout

Table 17-3 Hold and Lockout Codes

Code	Description	Note
226	Invalid Outlet high limit set point setting	Lockout
227	Invalid DHW high limit set point setting	Lockout
228	Invalid Stack limit set point setting	Lockout
229	Invalid Modulation output setting	Lockout
230	Invalid CH demand source setting	Lockout
231	Invalid Delta T limit delay setting	Lockout
232	Invalid Pressure sensor type setting	Lockout
233	Invalid IAS closed response setting	Lockout
234	Invalid Outlet high limit enable setting	Lockout
235	Invalid Outlet connector type setting	Lockout
236	Invalid Inlet connector type setting	Lockout
237	Invalid DHW connector type setting	Lockout
238	Invalid Stack connector type setting	Lockout
239	Invalid Header connector type setting	Lockout
240	Invalid Outdoor connector type setting	Lockout
241	Exchanger sensor not allowed with stack connector setting	Lockout
242	Invalid DHW auto detect configuration	Lockout
243	Invalid UV with spark interference not compatible with Igniter on throughout	Lockout
244	Internal fault: Safety relay test invalid state	Lockout
245	Invalid Outlet connector type setting for T-rise	Lockout
246	4-20mA cannot be used for both modulation and setpoint control	Lockout
247	Invalid ILK bounce detection enable	Lockout
248	Invalid forced recycle interval	Lockout
249	STAT cannot be demand source when Remote Stat is enabled	Lockout
250	Invalid Fan speed error response	Lockout
251	Lead drop-stage on error setting does not match drop method configuration	Lockout
252	Invalid Line frequency setting	Lockout
253	Lead Lag modulation sensor not valid with setpoint source	Lockout
254	Lead Lag modulation sensor not valid with local setpoint source	Lockout
255	Lead Lag modulation sensor not valid with local modulation source	Lockout
256	Selected Controller interaction enable setting is not allowed	Lockout
257	Controller interaction enable does not match neighbor stack fault setting	Lockout
258	Controller ID must be non-zero if controller interaction is enabled	Lockout
259	Modulation output must be fan if controller interaction is enabled	Lockout
260	Asymmetrical paired (no flap) is set but flap switch input is energized	Lockout
261	Neighbor burner control blower fault detected	Lockout
262	Blower fault detected during flap test	Lockout
263	Invalid DHW demand temperature setting	Lockout
264	Invalid preferred outlet high limit setting	Lockout
265	Invalid preferred lightoff rate setting	Lockout
266	Invalid preferred stack limit rate setting	Lockout

Table 17-4 Alert Codes

Code	Description
0	None (No alert)
1	Alert PCB was restored from factory defaults
2	Safety configuration parameters were restored from factory defaults

Table 17-4 Alert Codes

Code	Description
3	Configuration parameters were restored from factory defaults
4	Invalid Factory Invisibility PCB was detected
5	Invalid Factory Range PCB was detected
6	Invalid range PCB record has been dropped
7	EEPROM lockout history was initialized
8	Switched application annunciation data blocks
9	Switched application configuration data blocks
10	Configuration was restored from factory defaults
11	Backup configuration settings was restored from active configuration
12	Annunciation configuration was restored from factory defaults
13	Annunciation configuration was restored from backup
14	Safety group verification table was restored from factory defaults
15	Safety group verification table was updated
16	Invalid Parameter PCB was detected
17	Invalid Range PCB was detected
18	Alarm silence time exceeded maximum
19	Invalid safety group verification table was detected
20	Backdoor password could not be determined
21	Invalid safety group verification table was not accepted
22	CRC errors were found in application configuration data blocks
23	Backup Alert PCB was restored from active one
24	RESERVED
25	Lead Lag operation switch was turned OFF
26	Lead Lag operation switch was turned ON
27	Safety processor was reset
28	Application processor was reset
29	Burner switch was turned OFF
30	Burner switch was turned ON
31	Program Module (PM) was inserted into socket
32	Program Module (PM) was removed from socket
33	Alert PCB was configured
34	Parameter PCB was configured
35	Range PCB was configured
36	Program Module (PM) incompatible with product was inserted into socket
37	Program Module application parameter revision differs from application processor
38	Program Module safety parameter revision differs from safety processor
39	PCB incompatible with product contained in Program Module
40	Parameter PCB in Program Module is too large for product
41	Range PCB in Program Module was too large for product
42	Alert PCB in Program Module was too large for product
43	IAS start check was forced on due to IAS enabled
44	Low voltage was detected in safety processor
45	High line frequency occurred
46	Low line frequency occurred
47	Invalid subsystem reset request occurred
48	Write large enumerated Modbus register value was not allowed
49	Maximum cycle count was reached
50	Maximum hours count was reached
51	Illegal Modbus write was attempted

Table 17-4 Alert Codes

Code	Description
52	Modbus write attempt was rejected (NOT ALLOWED)
53	Illegal Modbus read was attempted
54	Safety processor brown-out reset occurred
55	Application processor watchdog reset occurred
56	Application processor brown-out reset occurred
57	Safety processor watchdog reset occurred
58	Alarm was reset by the user at the control
59	Burner control firing rate was > absolute max rate
60	Burner control firing rate was < absolute min rate
61	Burner control firing rate was invalid, % vs. RPM
62	Burner control was firing with no fan request
63	Burner control rate (non-firing) was > absolute max rate
64	Burner control rate (non-firing) was < absolute min rate
65	Burner control rate (non-firing) was absent
66	Burner control rate (non-firing) was invalid, % vs. RPM
67	Fan off cycle rate was invalid, % vs. RPM
68	Set point was over ridden due to sensor fault
69	Modulation was over ridden due to sensor fault
70	No demand source was set due to demand priority conflicts
71	CH 4-20mA signal was invalid.
72	Flame strength rate differential was invalid
73	Flame strength step rate was invalid
74	Periodic forced recycle
75	Absolute max fan speed was out of range
76	Absolute min fan speed was out of range
77	Fan gain down was invalid
78	Fan gain up was invalid
79	Fan minimum duty cycle was invalid
80	Fan pulses per revolution was invalid
81	Fan PWM frequency was invalid
82-83	RESERVED
84	Lead Lag CH 4-20mA water temperature setting was invalid
85	No Lead Lag add stage error threshold was configured
86	No Lead Lag add stage detection time was configured
87	No Lead Lag drop stage error threshold was configured
88	No Lead Lag drop stage detection time was configured
89	Lead Lag all boiler off threshold was invalid
90	Modulation output type was invalid
91	Firing rate control parameter was invalid
92	Forced rate was out of range vs. min/max modulation
93	Forced rate was invalid, % vs. RPM
94	Slow start ramp value was invalid
95	Slow start degrees value was invalid
96	Slow start was ended due to outlet sensor fault
97	Slow start was end due to reference set point fault
98	CH max modulation rate was invalid, % vs. RPM
99	CH max modulation rate was > absolute max rate
100	CH modulation range (max minus min) was too small (< 4% or 40 RPM)
101	DHW max modulation rate was invalid, % vs. RPM

Table 17-4 Alert Codes

Code	Description
102	DHW max modulation rate was > absolute max rate
103	DHW modulation range (max minus min) was too small (< 4% or 40 RPM)
104	Min modulation rate was < absolute min rate
105	Min modulation rate was invalid, % vs. RPM
106	Manual rate was invalid, % vs. RPM
107	Slow start enabled, but forced rate was invalid
108	Analog output hysteresis was invalid
109	Analog modulation output type was invalid
110	IAS open rate differential was invalid
111	IAS open step rate was invalid
112	Mix max modulation rate was invalid, % vs. RPM
113	Mix max modulation rate was > absolute max or < absolute min rates
114	Mix modulation range (max minus min) was too small (< 4% or 40 RPM)
115	Fan was limited to its minimum duty cycle
116	Manual rate was > CH max modulation rate
117	Manual rate was > DHW max modulation rate
118	Manual rate was < min modulation rate
119	Manual rate in Standby was > absolute max rate
120	Modulation commanded rate was > CH max modulation rate
121	Modulation commanded rate was > DHW max modulation rate
122	Modulation commanded rate was < min modulation rate
123	Modulation rate was limited due to outlet limit
124	Modulation rate was limited due to Delta-T limit
125	Modulation rate was limited due to stack limit
126	Modulation rate was limited due to anti-condensation
127	Fan Speed out of range in RUN
128	Modulation rate was limited due to IAS was open
129	Slow start ramp setting of zero will result in no modulation rate change
130	No forced rate was configured for slow start ramp
131	CH demand source was invalid
132	CH P-gain was invalid
133	CH I-gain was invalid
134	CH D-gain was invalid
135	CH OFF hysteresis was invalid
136	CH ON hysteresis was invalid
137	CH sensor type was invalid
138	CH hysteresis step time was invalid
139	CH remote control parameter was invalid
140	CH ODR not allowed with remote control
146	CH control was suspended due to fault
147	CH header temperature was invalid
148	CH outlet temperature was invalid
149	CH steam pressure was invalid
151	Minimum water temperature parameter was greater than setpoint
152	Minimum water temperature parameter was greater than time of day setpoint
155	CH modulation rate source parameter was invalid
157	DHW demand source was invalid
158	DHW P-gain was invalid
159	DHW I-gain was invalid

Table 17-4 Alert Codes

Code	Description
160	DHW D-gain was invalid
161	DHW OFF hysteresis was invalid
162	DHW ON hysteresis was invalid
163	DHW hysteresis step time was invalid
164	DHW sensor type was invalid
165	Inlet sensor type was invalid for DHW
166	Outlet sensor type was invalid for DHW
167	DHW storage OFF hysteresis was invalid
168	DHW storage ON hysteresis was invalid
169	DHW modulation sensor type was invalid
170	DHW modulation sensor was not compatible for Auto mode
171	DHW control was suspended due to fault
172	DHW temperature was invalid
173	DHW inlet temperature was invalid
174	DHW outlet temperature was invalid
175	DHW high limit must be disabled for Auto mode
176	DHW sensor type was not compatible for Auto mode
177	DHW priority source setting was invalid
178	DHW priority method setting was invalid
179	CH S5 (J8-11) sensor was invalid
180	CH Inlet temperature was invalid
181	CH S10 (J10-7) sensor was invalid
182	Lead Lag CH setpoint source was invalid
183	Lead Lag P-gain was invalid
184	Lead Lag I-gain was invalid
185	Lead Lag D-gain was invalid
186	Lead Lag OFF hysteresis was invalid
187	Lead Lag ON hysteresis was invalid
188	Lead Lag slave enable was invalid
189	Lead Lag hysteresis step time was invalid
190	No Lead Lag Modbus port was assigned
191	Lead Lag base load common setting was invalid
192	Lead Lag DHW demand switch setting was invalid
193	Lead Lag Mix demand switch setting was invalid
194	Lead Lag modulation sensor setting was invalid
195	Lead Lag backup modulation sensor setting was invalid
196	Lead Lag slave mode setting was invalid
197	Lead Lag rate allocation setting was invalid
198	Lead selection setting was invalid
199	Lag selection setting was invalid
200	Lead Lag slave return setting was invalid
201	Lead Lag add stage method setting was invalid
202	STAT may not be a Lead Lag CH demand source when Remote Stat is enabled
203	Lead Lag base load rate setting was invalid
204	Lead Lag master was suspended due to fault
205	Lead Lag slave was suspended due to fault
206	Lead Lag header temperature was invalid
207	Lead Lag was suspended due to no enabled Program Module installed
208	Lead Lag slave session has timed out

Table 17-4 Alert Codes

Code	Description
209	Too many Lead Lag slaves were detected
210	Lead Lag slave was discovered
211	Incompatible Lead Lag slave was discovered
212	No base load rate was set for Lead Lag slave
213	Lead Lag slave unable to fire before demand to fire delay expired
214	Adding Lead Lag slave aborted due to add requirement change
215	No Lead Lag slaves available to service demand
216	No Lead Lag active service was set due to demand priority conflicts
217	No Lead Lag add stage method was specified
218	No Lead Lag drop stage method was specified
219	Using backup Lead Lag header sensor due to sensor failure
220	Lead Lag frost protection rate was invalid
221	Lead Lag drop stage method setting was invalid
222	CH frost protection temperature was invalid
223	CH frost protection inlet temperature was invalid
224	DHW frost protection temperature was invalid
225	No anticondensation setpoint was configured for frost protection
226	RESERVED
227	DHW priority override time was not derated due to invalid outdoor temperature
228	Warm weather shutdown was not checked due to invalid outdoor temperature
229	Lead Lag slave communication timeout
230	RESERVED
231	LL set point was invalid
232	LL time of day set point was invalid
233	LL outdoor temperature was invalid
234	LL ODR time of day set point was invalid
235	LL ODR time of day set point exceeded normal set point
236	LL max outdoor set point was invalid
237	LL min outdoor set point was invalid
238	LL min water set point was invalid
239	LL outdoor temperature range was too small (minimum 12 C / 22 F)
240	LL water temperature range was too small (minimum 12 C / 22 F)
241	Lead Lag DHW setpoint was invalid
243	Lead Lag CH demand switch was invalid
244	Lead Lag ODR min water temperature was invalid
245	RESERVED
246	CH set point was invalid
247	CH time of day set point was invalid
248	CH outdoor temperature was invalid
249	CH ODR time of day setpoint was invalid
250	CH ODR time of day set point exceeds normal set point
251	CH max outdoor set point was invalid
252	CH min outdoor setp oint was invalid
253	CH min water set point was invalid
254	CH outdoor temperature range was too small (minimum 12 C / 22 F)
255	CH water temperature range was too small (minimum 12 C / 22 F)
259	CH ODR min water temperature was invalid
260	RESERVED
261	DHW set point was invalid

Table 17-4 Alert Codes

Code	Description
262	DHW time of day set point was invalid
263	DHW storage setpoint was invalid
264	STAT may not be a DHW demand source when Remote Stat is enabled
265	No DHW anticondensation setpoint was configured
266	No CH anticondensation setpoint was configured
267	STAT may not be a CH demand source when Remote Stat is enabled
268	CH 4mA water temperature setting was invalid
269	CH 20mA water temperature setting was invalid
270	Steam 4mA water temperature setting was invalid
271	Steam 20mA water temperature setting was invalid
272	Abnormal Recycle: Pressure sensor fault
273	Abnormal Recycle: Safety relay drive test failed
274	Abnormal Recycle: Demand off during Pilot Flame Establishing Period
275	Abnormal Recycle: LCI off during Drive to Purge Rate
276	Abnormal Recycle: LCI off during Measured Purge Time
277	Abnormal Recycle: LCI off during Drive to Light off Rate
278	Abnormal Recycle: LCI off during Pre-Ignition test
279	Abnormal Recycle: LCI off during Pre-Ignition time
280	Abnormal Recycle: LCI off during Main Flame Establishing Period
281	Abnormal Recycle: LCI off during Ignition period
282	Abnormal Recycle: Demand off during Drive to Purge Rate
283	Abnormal Recycle: Demand off during Measured Purge Time
284	Abnormal Recycle: Demand off during Drive to Light off Rate
285	Abnormal Recycle: Demand off during Pre-Ignition test
286	Abnormal Recycle: Demand off during Pre-Ignition time
287	Abnormal Recycle: Flame was on during Safe Start check
288	Abnormal Recycle: Flame was on during Drive to Purge Rate
289	Abnormal Recycle: Flame was on during Measured Purge Time
290	Abnormal Recycle: Flame was on during Drive to Light off Rate
291	Abnormal Recycle: Flame was not on at end of Ignition period
292	Abnormal Recycle: Flame was lost during Main Flame Establishing Period
293	Abnormal Recycle: Flame was lost early in Run
294	Abnormal Recycle: Flame was lost during Run
295	Abnormal Recycle: Leakage test failed
296	Abnormal Recycle: Interrupted air flow switch was off during Drive to Purge Rate
297	Abnormal Recycle: Interrupted air flow switch was off during Measured Purge Time
298	Abnormal Recycle: Interrupted air flow switch was off during Drive to Light off Rate
299	Abnormal Recycle: Interrupted air flow switch was off during Pre-Ignition test
300	Abnormal Recycle: Interrupted air flow switch was off during Pre-Ignition time
301	Abnormal Recycle: Interrupted air flow switch was off during Main Flame Establishing Period
302	Abnormal Recycle: Ignition failed due to interrupted air flow switch was off
303	Abnormal Recycle: ILK off during Drive to Purge Rate
304	Abnormal Recycle: ILK off during Measured Purge Time
305	Abnormal Recycle: ILK off during Drive to Light off Rate
306	Abnormal Recycle: ILK off during Pre-Ignition test
307	Abnormal Recycle: ILK off during Pre-Ignition time
308	Abnormal Recycle: ILK off during Main Flame Establishing Period
309	Abnormal Recycle: ILK off during Ignition period
310	Run was terminated due to ILK was off

Table 17-4 Alert Codes

Code	Description
311	Run was terminated due to interrupted air flow switch was off
312	Stuck reset switch
313	Run was terminated due to fan failure
314	Abnormal Recycle: Fan failed during Drive to Purge Rate
315	Abnormal Recycle: Fan failed during Measured Purge Time
316	Abnormal Recycle: Fan failed during Drive to Light off Rate
317	Abnormal Recycle: Fan failed during Pre-Ignition test
318	Abnormal Recycle: Fan failed during Pre-Ignition time
319	Abnormal Recycle: Fan failed during Ignition period
320	Abnormal Recycle: Fan failed during Main Flame Establishing Period
321	Abnormal Recycle: Main Valve off after 10 seconds of RUN
322	Abnormal Recycle: Pilot Valve off after 10 seconds of RUN
323	Abnormal Recycle: Safety Relay off after 10 seconds of RUN
324	Abnormal Recycle: Hardware flame bias
325	Abnormal Recycle: Hardware static flame
326	Abnormal Recycle: Hardware flame current invalid
327	Abnormal Recycle: Hardware flame rod short
328	Abnormal Recycle: Hardware invalid power
329	Abnormal Recycle: Hardware invalid AC line
330	Abnormal Recycle: Hardware SLO flame ripple
331	Abnormal Recycle: Hardware SLO flame sample
332	Abnormal Recycle: Hardware SLO flame bias range
333	Abnormal Recycle: Hardware SLO flame bias heat
334	Abnormal Recycle: Hardware SLO spark stuck
335	Abnormal Recycle: Hardware SLO spark changed
336	Abnormal Recycle: Hardware SLO static flame
337	Abnormal Recycle: Hardware SLO rod shorted
338	Abnormal Recycle: Hardware SLO AD linearity
339	Abnormal Recycle: Hardware SLO bias not set
340	Abnormal Recycle: Hardware SLO bias shorted
341	Abnormal Recycle: Hardware SLO electronics
342	Abnormal Recycle: Hardware processor clock
343	Abnormal Recycle: Hardware AC phase
344	Abnormal Recycle: Hardware A2D mismatch
345	Abnormal Recycle: Hardware VSNSR A2D
346	Abnormal Recycle: Hardware 28V A2D
347	Abnormal Recycle: Hardware HFS IAS shorted
348	Abnormal Recycle: Hardware PII INTLK shorted
349	Abnormal Recycle: Hardware HFS LCI shorted
350	Abnormal Recycle: Hardware HFS LFS shorted
351	Abnormal Recycle: Invalid zero crossing
352	Abnormal Recycle: fault stack sensor
353	Abnormal Recycle: stack limit
354	Abnormal Recycle: delta T limit
355	Abnormal Recycle: fault outlet sensor
356	Abnormal Recycle: outlet high limit
357	Abnormal Recycle: fault DHW sensor
358	Abnormal Recycle: DHW high limit
359	Abnormal Recycle: fault inlet sensor

Table 17-4 Alert Codes

Code	Description
360	Abnormal Recycle: Check Parameters Failed
361	Internal error: No factory parameters were detected in control
362	Internal error: PID iteration frequency was invalid
363	Internal error: Demand-Rate interval time was invalid
364	Internal error: Factory calibration parameter for modulation was invalid
365	Internal error: CH PID P-scaler was invalid
366	Internal error: CH PID I-scaler was invalid
367	Internal error: CH PID D-scaler was invalid
368	Internal error: DHW PID P-scaler was invalid
369	Internal error: DHW PID I-scaler was invalid
370	Internal error: DHW PID D-scaler was invalid
371	Internal error: Lead Lag master PID P-scaler was invalid
372	Internal error: Lead Lag master PID I-scaler was invalid
373	Internal error: Lead Lag master PID D-scaler was invalid
374	Abnormal Recycle: Hardware flame bias high
375	Abnormal Recycle: Hardware flame bias low
376	Abnormal Recycle: Hardware flame bias delta high
377	Abnormal Recycle: Hardware flame bias delta low
378	Abnormal Recycle: Hardware flame bias dynamic high
379	Abnormal Recycle: Hardware flame bias dynamic low
380	Abnormal Recycle: Fan Speed Not Proven
381	Abnormal Recycle: Fan Speed Range Low
382	Abnormal Recycle: Fan Speed Range High
383	Abnormal Recycle: Pre-Ignition test failed, recycle
384-388	RESERVED
389	Abnormal Recycle: AC power frequency Mismatch
390-447	RESERVED
448	Flame too low
449	Modulation rate was limited due to flame strength
450	RESERVED
451	Circulator control was invalid
452	Circulator P-gain was invalid
453	Circulator I-gain was invalid
454	Circulator temperature was invalid
455	Circulator outlet temperature was invalid
456	Circulator inlet temperature was invalid
457	Circulator outlet temperature was invalid
458	Circulator sensor choice was invalid
459	Circulator PID setpoint was invalid
460	LCI demand lost in run
461	Demand lost in run
462	STAT demand lost in run
463	Demand lost in run due to no flame
464	LCI lost in Combustion Pressure Establishing Period
465	LCI lost in Combustion Pressure Stabilizing Period
466	RESERVED
467	Internal error: EEPROM write was attempted before EEPROM was initialized
468	Internal error: EEPROM cycle count address was invalid
469	Internal error: EEPROM days count address was invalid

Table 17-4 Alert Codes

Code	Description
470	Internal error: EEPROM hours count address was invalid
471	Internal error: Lockout record EEPROM index was invalid
472	Internal error: Request to write PM status was invalid
473	Internal error: PM parameter address was invalid
474	Internal error: PM safety parameter address was invalid
475	Internal error: Invalid record in lockout history was removed
476	Internal error: EEPROM write buffer was full
477	Internal error: Data too large was not written to EEPROM
478	Internal error: Safety key bit 0 was incorrect
479	Internal error: Safety key bit 1 was incorrect
480	Internal error: Safety key bit 2 was incorrect
481	Internal error: Safety key bit 3 was incorrect
482	Internal error: Safety key bit 4 was incorrect
483	Internal error: Safety key bit 5 was incorrect
484	Internal error: Safety key bit 6 was incorrect
485	Internal error: Safety key bit 7 was incorrect
486	Internal error: Safety key bit 8 was incorrect
487	Internal error: Safety key bit 9 was incorrect
488	Internal error: Safety key bit 10 was incorrect
489	Internal error: Safety key bit 11 was incorrect
490	Internal error: Safety key bit 12 was incorrect
491	Internal error: Safety key bit 13 was incorrect
492	Internal error: Safety key bit 14 was incorrect
493	Internal error: Safety key bit 15 was incorrect
494	Internal error: Safety relay timeout
495	Internal error: Safety relay commanded off
496	Internal error: Unknown safety error occurred
497	Internal error: Safety timer was corrupt
498	Internal error: Safety timer was expired
499	Internal error: Safety timings
500	Internal error: Safety shutdown
550	Delta T inlet/outlet limit was exceeded
553	Inlet/outlet inversion occurred
564	Outlet T-rise limit was exceeded
600	Delta T inlet temperature was invalid
601	Delta T outlet temperature was invalid
603	CH ODR boost max offpoint temperature was invalid
604	CH ODR boost max offpoint temperature was too low
605	Lead Lag ODR boost max offpoint temperature was invalid
606	Lead Lag ODR boost max offpoint temperature was too low
609	Time to rotate lead boiler to next firing slave
610	Time to rotate lead boiler to next available slave
611	Time to rotate lead boiler to first firing slave in order
612	Time to rotate lead boiler to lowest running slave
613	Lead boiler was rotated based on new firing sequence order
614	Lead boiler was rotated based on measured run time
615	Parameter PCB was switched to backup
616	Range PCB was switched to backup
622	Lead Lag modulation sensor was not valid with setpoint source

Table 17-4 Alert Codes

Code	Description
623	Lead Lag modulation sensor was not valid with local setpoint source
624	Lead Lag modulation sensor was not valid with local modulation rate source
629	Disagreement on number of interacting controls



Ace Heaters, LLC
130 Klug Circle., Corona CA 92878 · 951-738-2230 tel · 951-281-4959 fax
www.aceheaters.com





Aceheaters.com
130 Klug Circle
Corona, CA 92878

(951) 738-2230