

SIHDWWA-3W, DW - WATER - PNEUMATIC 3-WAY MIXING VALVE PACKAGE

| MP SIZE | 5 | 6 | 8 | 10 | 12 | 14 | 16 |
|------------------|------------|------------|---------|----------|----------|----------|---------|
| ITEMS | 10 | 10 1/2 | 11 1/2 | 13 1/2 | 14 1/2 | 15 1/2 | 16 1/2 |
| 1 | 7 11/16 | 8 3/16 | 10 1/8 | 10 13/16 | 12 1/2 | 12 1/4 | 14 |
| 2 | 14 7/8 | 15 3/8 | 18 5/16 | 22 | 26 7/8 | 26 5/8 | 28 3/8 |
| 3 | 10 5/8 | 11 1/4 | 12 1/8 | 13 3/8 | 15 5/8 | 17 11/16 | 18 9/16 |
| 4 | 61 1/2 | 62 | 61 3/4 | 64 | 62 1/2 | 72 | 75 3/4 |
| 5 | 80 3/16 | 81 5/16 | 83 9/16 | 85 9/16 | 88 7/16 | 100 7/8 | 106 1/2 |
| 6 | 8 3/4 | 9 7/8 | 11 7/8 | 14 1/2 | 16 5/8 | 18 1/2 | 20 |
| 7 | 65 7/8 | 66 7/8 | 68 | 69 1/2 | 70 11/16 | 80 5/16 | 83 7/16 |
| 8 | 11 3/4 | 11 3/4 | 12 5/8 | 13 3/8 | 14 3/16 | 18 | 19 1/2 |
| 9 | 1 3/8 | 1 1/2 | 2 1/16 | 2 1/2 | 3 1/16 | 3 1/8 | 3 1/4 |
| 10 | 64 | 64 | 64 | 64 | 64 | 75 | 80 |
| 11 | 2 1/2 | 2 1/2 | 2 1/2 | 2 1/2 | 2 1/2 | 2 1/2 | 2 1/2 |
| 12 | 30 1/8 | 30 1/16 | 33 9/16 | 37 1/4 | 40 3/16 | 41 1/4 | 42 1/2 |
| 13 | 2 1/2 FLG. | 2 1/2 FLG. | 3 FLG. | 4 FLG. | 4 FLG. | 5 FLG. | 6 FLG. |
| INLET PIPE SIZE | 2 1/2 FLG. | 2 1/2 FLG. | 3 FLG. | 4 FLG. | 4 FLG. | 5 FLG. | 6 FLG. |
| OUTLET PIPE SIZE | 2 1/2 FLG. | 2 1/2 FLG. | 3 FLG. | 4 FLG. | 4 FLG. | 5 FLG. | 6 FLG. |

| VALVE SIZE 'A' | ITEM | VALVE SIZE AND OVERALL LOCATION | | | | | | |
|----------------|------|---------------------------------|----------|----------|----------|----------|----------|----------|
| 1/2" | 'B' | 12 7/8 | 13 3/8 | 16 1/3 | 20 | 24 7/8 | 24 5/8 | 26 3/8 |
| | 'C' | 16 1/16 | 16 5/16 | 17 5/16 | 19 13/16 | 21 5/16 | 23 5/16 | 25 5/16 |
| | 'D' | 30 11/16 | 31 3/16 | 34 1/8 | 37 13/16 | 42 11/16 | 42 7/16 | 44 3/16 |
| 3/4" | 'B' | 12 5/8 | 13 1/8 | 16 | 19 3/4 | 24 5/8 | 24 3/8 | 26 1/8 |
| | 'C' | 17 1/16 | 17 5/16 | 18 5/16 | 20 13/16 | 22 5/16 | 24 5/16 | 26 5/16 |
| | 'D' | 30 11/16 | 31 3/16 | 34 1/8 | 37 13/16 | 42 11/16 | 42 7/16 | 44 3/16 |
| 1" | 'B' | 12 5/8 | 13 1/8 | 16 1/16 | 19 3/4 | 24 5/8 | 24 3/8 | 26 1/8 |
| | 'C' | 17 1/16 | 17 5/16 | 18 5/16 | 20 13/16 | 22 5/16 | 24 5/16 | 26 5/16 |
| | 'D' | 30 11/16 | 31 3/16 | 34 1/8 | 37 13/16 | 42 11/16 | 42 7/16 | 44 3/16 |
| 1 1/4" | 'B' | 12 3/8 | 12 7/8 | 15 4/5 | 19 1/2 | 24 3/8 | 24 1/8 | 25 7/8 |
| | 'C' | 17 1/16 | 17 5/16 | 18 5/16 | 20 13/16 | 22 5/16 | 24 5/16 | 26 5/16 |
| | 'D' | 30 11/16 | 31 3/16 | 34 1/8 | 37 13/16 | 42 11/16 | 42 7/16 | 44 3/16 |
| 1 1/2" | 'B' | 11 7/8 | 12 3/8 | 15 5/16 | 19 | 23 7/8 | 23 5/8 | 25 3/8 |
| | 'C' | 17 1/16 | 17 5/16 | 18 5/16 | 20 13/16 | 22 5/16 | 24 5/16 | 26 5/16 |
| | 'D' | 31 7/16 | 31 15/16 | 34 7/8 | 38 9/16 | 43 7/16 | 43 3/16 | 44 15/16 |
| 2" | 'B' | 10 7/8 | 11 3/8 | 14 5/16 | 18 | 22 7/8 | 22 5/8 | 24 3/8 |
| | 'C' | 18 7/16 | 18 11/16 | 19 11/16 | 22 3/16 | 23 11/16 | 25 11/16 | 27 11/16 |
| | 'D' | 33 1/8 | 33 5/8 | 36 9/16 | 40 1/4 | 45 1/8 | 44 7/8 | 46 5/8 |
| 2 1/2" | 'B' | 10 7/8 | 11 3/8 | 14 5/16 | 18 | 22 7/8 | 22 5/8 | 24 3/8 |
| | 'C' | 15 3/4 | 16 | 17 | 19 1/2 | 21 | 23 | 25 |
| | 'D' | 33 7/8 | 34 3/8 | 37 5/16 | 41 | 45 7/8 | 45 5/8 | 47 3/8 |
| 3" | 'B' | N/A | 11 1/8 | 14 1/16 | 17 3/4 | 22 5/8 | 22 3/8 | 24 1/8 |
| | 'C' | N/A | 17 | 18 | 20 1/2 | 22 | 24 | 26 |
| | 'D' | N/A | 36 1/4 | 39 3/16 | 42 7/8 | 47 3/4 | 47 1/2 | 49 1/4 |
| 4" | 'B' | N/A | N/A | 13 5/16 | 17 | 21 7/8 | 21 5/8 | 23 3/8 |
| | 'C' | N/A | N/A | 21 | 23 1/2 | 25 | 27 | 29 |
| | 'D' | N/A | N/A | 41 3/16 | 44 7/8 | 49 3/4 | 49 1/2 | 51 1/4 |
| 5" | 'B' | N/A | N/A | N/A | 16 | 20 7/8 | 20 5/8 | 22 3/8 |
| | 'C' | N/A | N/A | N/A | 26 1/4 | 27 3/4 | 29 3/4 | 31 3/4 |
| | 'D' | N/A | N/A | N/A | 44 7/8 | 49 3/4 | 49 1/2 | 51 1/4 |

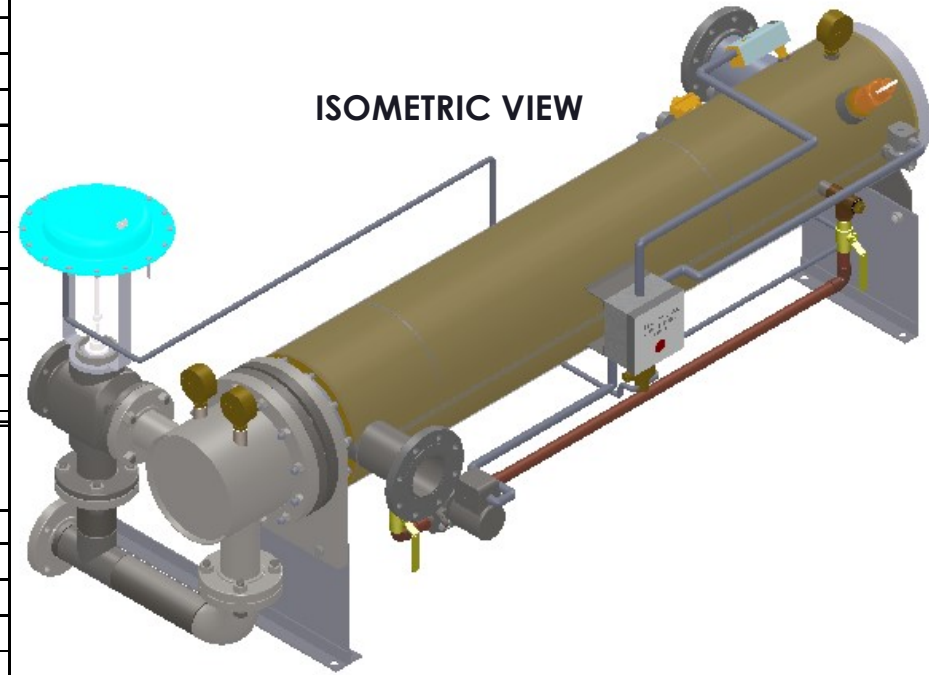

NOTES:

- 1/ DIMENSIONS IN INCHES, AND SUBJECT TO CHANGE WITHOUT NOTICE.
- 2/ DIM 'B', 'C', 'D' ARE TO BE APPROXIMATED ONLY, CONSULT FACTORY FOR TIGHT DIMENSIONS.



a nudyne company

Ace Heaters, LLC

www.aceheaters.com



ASME SECTION VIII DIV 1 :
DESIGN PRESSURE : (150) psig
TEST PRESSURE : (195) psig
MAX DESIGN TEMPERATURE : 370 °F

| NAME | DATE |
|-----------|------------|
| K.JIMENEZ | 04/12/2023 |
| | |
| | |
| | |
| | |

| | |
|---|-------------------------------|
| MATERIAL : | TITLE : SIHDW - COVER |
| FINISH : | MINIPACK SYSTEM-HORIZONTAL DW |
| WEIGHT : | WATER - PNEUMATIC OPERATED |
| | VALVE PACKAGE |
| UNLESS OTHERWISE SPECIFIED DIMENSIONS ARE IN INCHES | DWG NO. SIHDWWA-3W-DIM |
| TOLERANCE | REV. 02 |
| DECIMALS .XX ± .05 | SCALE : N/A |
| ANGULAR .XXX ± .010 | S/O # |
| MAX SURF | SHEET : 2 OF 2 |

THE INFORMATION CONTAINED WITHIN THIS DRAWING IS PROPRIETARY AND THE SOLE PROPERTY OF ACE HEATERS, LLC. ANY REPRODUCTION IN PART OR AS A WHOLE WITHOUT THE WRITTEN PERMISSION OF ACE HEATERS, LLC IS PROHIBITED.