

ISOMETRIC VIEW

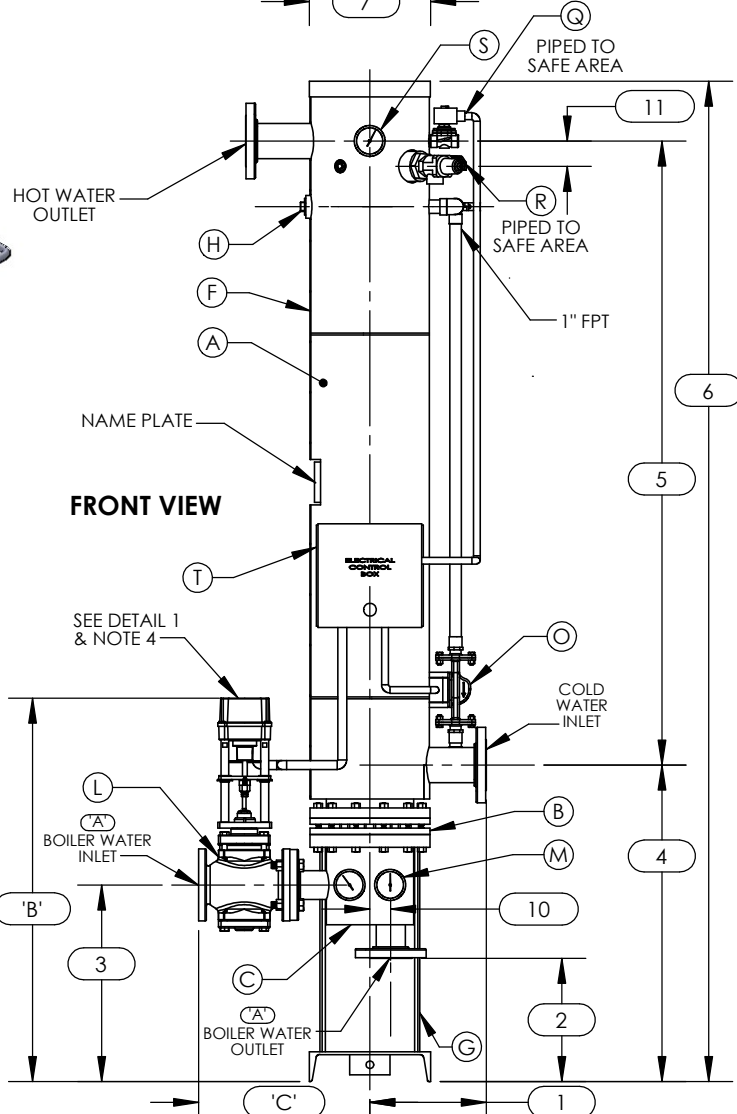
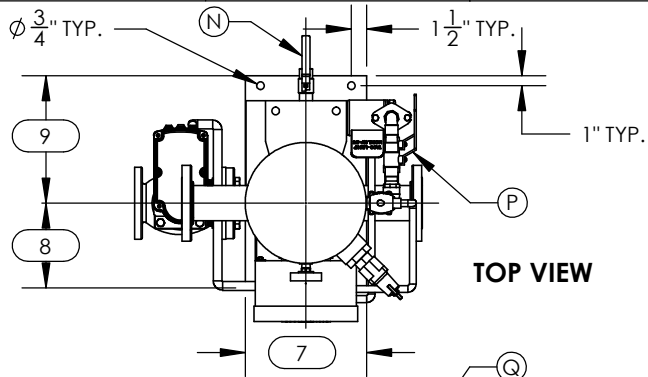

NOTES:

1. REFER TO PRODUCT SPECIFICATION FOR DESCRIPTION OF LETTERED ITEMS.
2. INSTALLATION:
ALL COMPONENTS SHOWN HERE ARE PREWIRED & PREPARED BY ACE HEATERS, LLC. CUSTOMER WILL ONLY NEED TO PLUMB WATER TO BE HEATED, PLUMB BOILER WATER, HOOKUP AIR TO AIR FILTER-PRESSURE REGULATOR, AND BRING ELECTRICITY TO UNIT.
3. DIMENSIONS ARE SUBJECT TO CHANGE. CONSULT FACTORY FOR TIGHT DIMENSIONS.
4. THIS CONFIGURATION CHANGES FOR VALVE SIZE 1/2" TO 2". SEE DETAIL 2 FOR REFERENCE.
5. ADD 6" SPOILER TO CAP INLET IF APPL.

APPROX. EMPTY WT:

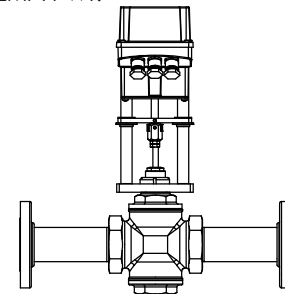

DETAIL 1



	CERTIFIED BY Ace Heaters, LLC www.aceheaters.com
	MAXIMUM ALLOWABLE WORKING PRESSURE SHELL 150 PSI @ 210 °F TUBES 150 PSI @ 370 °F
	MIN. D.M.T. 0 °F @ 150 PSI
	S/N _____ YEAR BUILT _____
	MODEL _____ CAPACITY _____ GAL SA _____ SQFT JOB NO. _____ XXX



Ace Heaters, LLC
www.aceheaters.com

DESIGNED BY	K. JIMENEZ	DATE	04/12/2023
CHECKED BY			
APPROVED BY			
SCALE			

MATERIAL:	TITLE: SIVDW - COVER MINIPACK SYSTEM-VERTICAL DW WATER 2W ELECTRIC OPERATED VALVE PACKAGE
FINISH:	
WEIGHT:	
UNLESS OTHERWISE SPECIFIED DIMENSIONS ARE IN INCHES TOLERANCE	DWG NO. SIVDWWE-2W
DECIMALS .XX # @ XX# # .010	ANGULAR # 3 MAX SURF
SCALE: NA	SO#
	SHEET: 1 OF 2

SIVSWWE-2W, WATER ELECTRIC OPERATED VALVE PACKAGE SIZE AND LOCATION

MP SIZE	5	6	8	10	12	14	16	
ITEMS	1	10	10 1/2	11 1/2	13 1/2	14 1/2	15 1/2	16 1/2
D	2	10 3/16	12 11/16	12 3/16	16 5/8	18 1/2	16 15/16	17 7/16
I	3	16 15/16	19 5/16	19 7/16	23 3/4	22 1/2	23 15/16	24 7/16
M	4	27 9/16	30 9/16	31 5/16	35 5/8	39 3/8	41 5/8	43 7/8
E	5	61 1/2	62	61 3/4	64	62 1/2	72	75 3/4
S	6	93 7/8	97 3/8	98 5/8	105 1/4	110	121	127
I	7	12	12	12	18	18	18	18
O	8	11 1/16	10 3/8	9 1/4	13 11/16	12	15 1/4	13 1/2
N	9	9 15/16	10 5/8	11 3/4	13 5/16	15	14 3/4	16 1/2
S	10	1 3/8	1 1/2	2 1/16	2 1/2	3 1/16	3 1/8	3 1/4
	11	2 1/2	2 1/2	2 1/2	2 1/2	2 1/2	2 1/2	2 1/2
INLET PIPE SIZE		2 1/2 FLG.	2 1/2 FLG.	3 FLG.	4 FLG.	4 FLG.	5 FLG.	6 FLG.
OUTLET PIPE SIZE		2 1/2 FLG.	2 1/2 FLG.	3 FLG.	4 FLG.	4 FLG.	5 FLG.	6 FLG.

'A' VALVE SIZE	ITEM	VALVE SIZE AND OVERALL LOCATION						
1/2"	'B'	32 11/16	35 1/16	35 3/16	39 1/2	38 1/4	39 11/16	40 3/16
	'C'	17 5/8	17 7/8	18 7/8	21 3/8	22 7/8	24 7/8	26 7/8
3/4"	'B'	32 11/16	35 1/16	35 3/16	39 1/2	38 1/4	39 11/16	40 3/16
	'C'	17 5/8	17 7/8	18 7/8	21 3/8	22 7/8	24 7/8	26 7/8
1"	'B'	32 11/16	35 1/16	35 3/16	39 1/2	38 1/4	39 11/16	40 3/16
	'C'	17 5/8	17 7/8	18 7/8	21 3/8	22 7/8	24 7/8	26 7/8
1 1/4"	'B'	33 5/16	35 11/16	35 13/16	40 1/8	38 7/8	40 5/16	40 13/16
	'C'	18 1/2	18 3/4	19 3/4	22 1/4	23 3/4	25 3/4	27 3/4
1 1/2"	'B'	33 5/16	35 11/16	35 13/16	40 1/8	38 7/8	40 5/16	40 13/16
	'C'	18 1/2	18 3/4	19 3/4	22 1/4	23 3/4	25 3/4	27 3/4
2"	'B'	33 9/16	35 15/16	36 1/16	40 3/8	39 1/8	40 9/16	41 1/16
	'C'	19 1/4	19 1/2	20 1/2	23	24 1/2	26 1/2	28 1/2
2 1/2"	'B'	35 15/16	38 5/16	38 7/16	42 3/4	41 1/2	42 15/16	43 7/16
	'C'	15 3/4	16	17	19 1/2	21	23	25
3"	'B'	N/A	38 15/16	39 1/16	43 3/8	42 1/8	43 9/16	44 1/16
	'C'		17	18	20 1/2	22	24	26
4"	'B'	N/A	N/A	40 3/16	44 1/2	43 1/4	44 11/16	45 3/16
	'C'			21	23 1/2	25	27	29
5"	'B'	N/A	N/A	N/A	45	43 3/4	45 3/16	45 11/16
	'C'				26 1/4	27 3/4	29 3/4	31 3/4

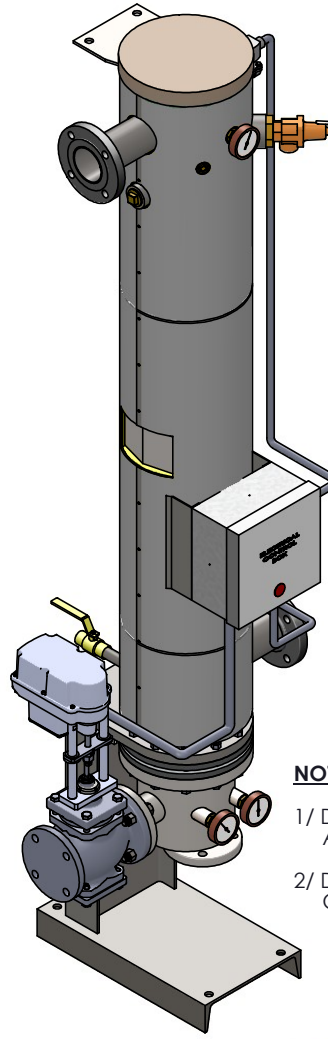

ISOMETRIC VIEW

NOTES:

- 1/ DIMENSIONS IN INCHES, AND SUBJECT TO CHANGE WITHOUT NOTICE.
- 2/ DIM 'B', 'C' ARE TO BE APPROXIMATED ONLY, CONSULT FACTORY FOR TIGHT DIMENSIONS.



Ace Heaters, LLC

www.aceheaters.com



DESIGN	K. JIMENEZ	04/12/2023
APP'D		
SCALE		
DATE		

MATERIAL:	TITLE: SIVDW - COVER
FINISH:	MINIPACK SYSTEM-VERTICAL DW
WEIGHT:	WATER 2W ELECTRIC OPERATED VALVE PACKAGE
UNLESS OTHERWISE SPECIFIED DIMENSIONS ARE IN INCHES TOLERANCE	DWG NO. SIVDWWE-2W-DIM
DECIMALS .XX	ANGULAR ± 3
XX ± .010	MAX SURF
SCALE: N/A	SHEET: 2 OF 2