

ISOMETRIC VIEW

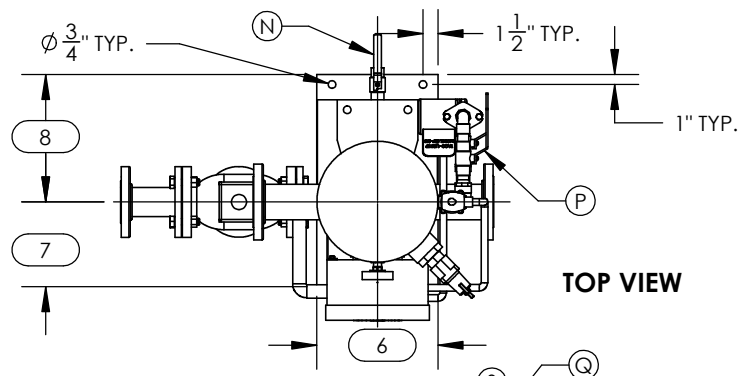

TOP VIEW

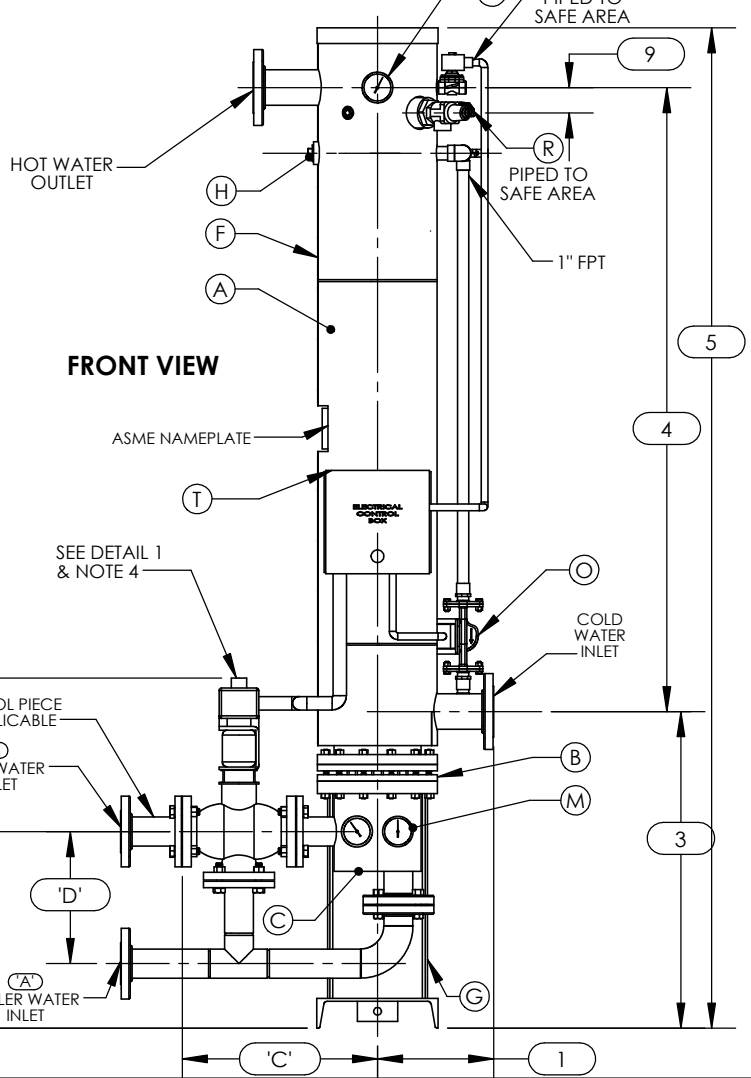

FRONT VIEW

NOTES:

1. REFER TO PRODUCT SPECIFICATION FOR DESCRIPTION OF LETTERED ITEMS.
2. INSTALLATION:
ALL COMPONENTS SHOWN HERE ARE PREWIRED & PREPIPED BY ACE HEATERS, LLC. CUSTOMER WILL ONLY NEED TO PLUMB WATER TO BE HEATED, PLUMB BOILER WATER, HOOKUP AIR TO AIR FILTER-PRESSURE REGULATOR, AND BRING ELECTRICITY TO UNIT.
3. DIMENSIONS ARE SUBJECT TO CHANGE. CONSULT FACTORY FOR TIGHT DIMENSIONS.
4. THIS CONFIGURATION CHANGES FOR VALVE SIZE 1/2" TO 2". SEE DETAIL 2 FOR REFERENCE.
5. ADD 6" SPOILER TO CAP INLET IF APPL.

APPROX. EMPTY WT:

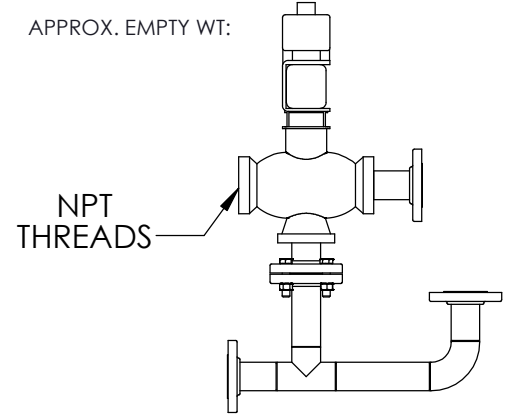

DETAIL 1



	CERTIFIED BY	
	Ace Heaters, LLC	
	www.aceheaters.com	
	MAXIMUM ALLOWABLE WORKING PRESSURE	
	SHELL	150 PSI @ 210 °F
TUBES	150 PSI @ 370 °F	
MIN. D.M.T. 0 °F @ 150 PSI		
S/N _____ YEAR BUILT _____		
MODEL _____		
CAPACITY _____ GAL SA. _____ SQFT		
JOB NO. _____ XXX		



Ace Heaters, LLC
www.aceheaters.com

ASME SECTION VIII DIV 1: DESIGN PRESSURE: (150) psig TEST PRESSURE: (195) psig MAX DESIGN TEMPERATURE: 370 °F		MATERIAL: FINISH: WEIGHT:		TITLE: SIVDW - COVER MINIPACK SYSTEM-VERTICAL DW WATER 3W - SIEMENS ELECTRIC OPERATED VALVE PACKAGE	
DRWNS K. JIMENEZ 04/12/2023 CHDAD APPVD MFG QA		UNLESS OTHERWISE SPECIFIED DIMENSIONS ARE IN INCHES TOLERANCE DECIMALS .XX ± .010 ANGULAR ± .5 XXX ± .010 MAX SURF		DWG NO. SIVDWWE-3W-SIE REV. 02 SCALE: NA SO# SHEET: 1 OF 2	

SIVSWWE-3W-SIE, 3W - WATER - ELECTRIC SIEMENS OPERATED VALVE PACKAGE SIZE AND LOCATION

	MP SIZE	5	6	8	10	12	14	16
ITEMS	1	10	10 1/2	11 1/2	13 1/2	14 1/2	15 1/2	16 1/2
D	2	16 15/16	19 5/16	19 7/16	23 3/4	22 1/2	23 15/16	24 7/16
I	3	27 9/16	30 9/16	31 5/16	35 5/8	39 3/8	41 5/8	43 7/8
M	4	61 1/2	62	61 3/4	64	62 1/2	72	75 3/4
E	5	93 7/8	97 3/8	98 5/8	105 1/4	110	121	127
S	6	12	12	12	18	18	18	18
I	7	11 1/16	10 3/8	9 1/4	13 11/16	12	15 1/4	13 1/2
O	8	9 15/16	10 5/8	11 3/4	13 5/16	15	14 3/4	16 1/2
N	9	2 1/2	2 1/2	2 1/2	2 1/2	2 1/2	2 1/2	2 1/2
S								
INLET PIPE SIZE		2 1/2 FLG.	2 1/2 FLG.	3 FLG.	4 FLG.	4 FLG.	5 FLG.	6 FLG.
OUTLET PIPE SIZE		2 1/2 FLG.	2 1/2 FLG.	3 FLG.	4 FLG.	4 FLG.	5 FLG.	6 FLG.

'A' VALVE SIZE	ITEM	VALVE SIZE AND OVERALL LOCATION						
1/2"	'B'	26 3/8	28 3/4	28 7/8	33 3/16	31 15/16	33 3/8	33 7/8
	'C'	12 1/16	12 5/16	13 5/16	15 13/16	17 5/16	19 5/16	21 5/16
	'D'	11	13	13	16	18	16	17
3/4"	'B'	27 3/16	29 9/16	29 11/16	34	32 3/4	34 3/16	34 11/16
	'C'	12 11/16	12 15/16	13 15/16	16 7/16	17 15/16	19 15/16	21 15/16
	'D'	11	13	13	16	18	16	17
1"	'B'	27 9/16	29 15/16	30 1/16	34 3/8	33 1/8	34 9/16	35 1/16
	'C'	13 1/4	13 1/2	14 1/2	17	18 1/2	20 1/2	22 1/2
	'D'	11	13	13	16	18	16	17
1 1/4"	'B'	28 3/16	30 9/16	30 11/16	35	33 3/4	35 3/16	35 11/16
	'C'	13 7/8	14 1/8	15 1/8	17 5/8	19 1/8	21 1/8	23 1/8
	'D'	11	13	13	16	18	16	17
1 1/2"	'B'	29 9/16	31 15/16	32 1/16	36 3/8	35 1/8	36 9/16	37 1/16
	'C'	14 7/16	14 11/16	15 11/16	18 3/16	19 11/16	21 11/16	23 11/16
	'D'	11	13	13	16	18	16	17
2"	'B'	30 5/16	32 11/16	32 13/16	37 1/8	35 7/8	37 5/16	37 13/16
	'C'	15 5/8	15 7/8	16 7/8	19 3/8	20 7/8	22 7/8	24 7/8
	'D'	11	13	13	16	18	16	17
2 1/2"	'B'	32 1/8	34 1/2	34 5/8	38 15/16	37 11/16	39 1/8	39 5/8
	'C'	18 3/16	18 7/16	19 7/16	21 15/16	23 7/16	25 7/16	27 7/16
	'D'	11	13	13	16	18	16	17
3"	'B'		39 9/16	39 11/16	44	42 3/4	44 3/16	44 11/16
	'C'	N/A	19 1/4	20 1/4	22 3/4	24 1/4	26 1/4	28 1/4
	'D'		13	13	16	18	16	17
4"	'B'			42 1/4	46 9/16	45 5/16	46 3/4	47 1/4
	'C'	N/A	N/A	21 3/4	24 1/4	25 3/4	27 3/4	29 3/4
	'D'			16	16	18	16	17
5"	'B'				46 9/16	45 5/16	46 3/4	47 1/4
	'C'	N/A	N/A	N/A	24 1/2	26	28	30
	'D'				16	18	16	17

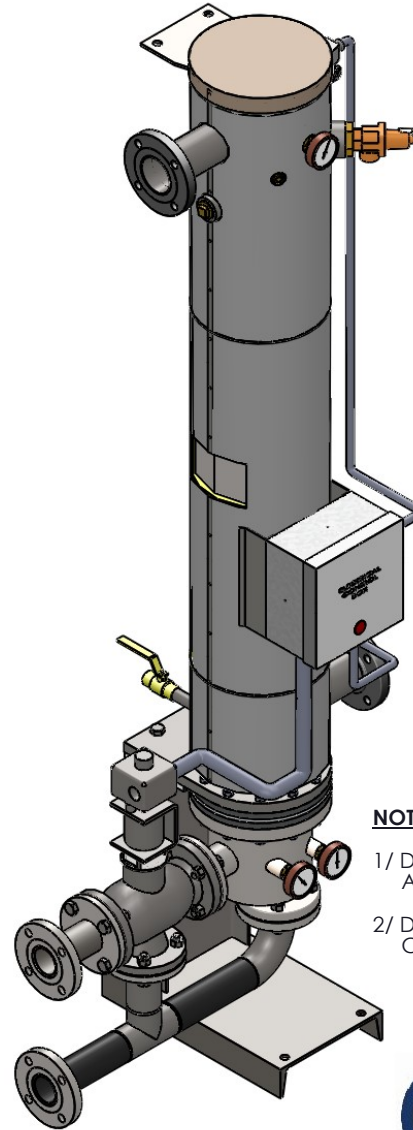

ISOMETRIC VIEW

NOTES:

- 1/ DIMENSIONS IN INCHES, AND SUBJECT TO CHANGE WITHOUT NOTICE.
- 2/ DIM 'B', 'C', 'D' ARE TO BE APPROXIMATED ONLY, CONSULT FACTORY FOR TIGHT DIMENSIONS.



a nudyne company

Ace Heaters, LLC

www.aceheaters.com



ASME SECTION VIII DIV 1		
DESIGN PRESSURE : (150) psig		
TEXT PRESSURE : (10) psig		
MAX DESIGN TEMPERATURE : 370 °F		
REV#	NAME	DATE
0000	K. JIMENEZ	04/12/2023
APP'D		
ENG		
QA		

MATERIAL :	TITLE :	REV.
FINISH :	SIVDW - COVER	02
WEIGHT :	MINIPACK SYSTEM-VERTICAL DW	
	WATER 3W - SIEMENS ELECTRIC	
	OPERATED VALVE PACKAGE	
UNLESS OTHERWISE SPECIFIED DIMENSIONS ARE IN INCHES TOLERANCE	DWG NO.	
DECIMALS .XX ± .01	SIVDWWE-3W-SIE-DIM	
ANGULAR ± .5	SCALE : NA	SHEET : 2 OF 2
MAX SURF .010	SO#	

THE INFORMATION CONTAINED WITHIN THIS DRAWING IS PROPRIETARY AND THE SOLE PROPERTY OF ACE HEATERS, LLC. ANY REPRODUCTION IN PART OR AS A WHOLE WITHOUT THE WRITTEN PERMISSION OF ACE HEATERS, LLC IS PROHIBITED.