



B Series

Atmospheric Gas Fired Water Heater/Boiler

B Series

Atmospheric Gas Fired Water Heater/Boiler



The Ace Series Water Heaters perform dependably and quietly, providing commercial, institutional, and industrial buildings with potable hot water. The even flow copper fin coils are designed to be energy efficient throughout the life of the unit.

Features

- Proven, energy efficient design
- Indoor and outdoor construction
- ETL Listed for natural gas or propane
- Conical copper fin coil
- Simple maintenance
- Completely delimeable heat exchanger
- Small foot print



Standard Equipment

Boiler

- Single flow cone coil design with complete water section, including heat exchanger with cast bronze manifolds
- Heat exchanger coiled from high profile finned copper tubing
- Non-ferrous construction with no gasketed joints
- ASME Section IV, stamped for 160 psig maximum allowable working pressure (MAWP)
- Stainless steel combustion chamber
- Spun aluminum top cap and 1” ceramic fiberglass insulation inside Aluminized steel casing with 2” thick outer insulation; additional 22 gauge mirror finish stainless steel jacket for outdoor models
- Boiler legs and bolt down lugs

Gas Burner

- Cast iron ported burner with integral venturi tube and orifice for use with natural gas

Controls & Trim

- Control power 120V/1ph/60Hz single-phase electronic intermittent pilot module with electric ignition
- Combination dual-automatic valve/regulator/gas-cock with leakage test cock
- Operating control and high limit temperature control with manual reset
- Water flow switch
- Pressure relief valve set at 125 psig
- Temperature-pressure gauge
- On-off firing mode
- 24V control circuit transformer
- CSD-1 control system

Optional Equipment

Boiler

- Propane burner

Controls & Trim

- Pressure relief valve set at 30, 50, or 75 psig
- Base for two or more boilers
- Bronze circulating pump
- Stack sensor/pump delay
- Delimiting kit

Valve Packages

- Low Temp. Systems: For inlet water temperature below 140°F
- Hydronic Systems: For use in hydronic applications with low temperature rises

Tank / Heater Packages

- Available with Ace Series Storage Tanks pre-piped to one or more heaters, floor- or skid-mounted, insulated and jacketed

MODEL	CIRC. PUMP HP	CIRC. PUMP SIZE ¹	VENT TYPE	INDOOR VENT DIA.	WATER PIPE SIZE	GAS PIPE SIZE	WATER VOL. GALS.	SHIPPING DIMENSION ² (W" x L" x H")
B2G	1/10	1	DH	6	1.5	3/4	0.3	31x31x45
B3G	1/10	1	DH	8	1.5	3/4	0.5	31x31x45
B4G	1/10	1	DH	10	1.5	3/4	0.7	33x37x49
B5G	1/10	1	DH	10	1.5	1	0.8	33x37x49
B7G	1/4	1	DH	12	1.5	1	2.2	40x45x52
B8G	1/4	1	DH	12	1.5	1/4	2.2	40x45x52
B11G	1/4	1	DH	14	1.5	1/4	3.2	40x45x55
B13G	1/2	1 1/2	BD	16	1.5	1/4	3.8	51x51x61
B15G	3/4	1 1/2	BD	16	1.5	1/4	4.3	51x51x60

¹ Optional circulation pump. Higher head pump must be used to compensate for roof top piping losses.

² Indoor models only. Other models, please consult factory for shipping dimensions.



Ace Series water heaters are engineered to meet continuous load demands. Continuous output is the rated output of the heater.

Peak load output is the rated output of the heater plus drawing upon the storage tank reserve capacity. Shorter peak load capacities, at higher output rates and longer peak loads at lower rates, can be handled by the Ace Series Packaged Hot Water Systems. In addition to peak load capacities, the Ace Series will handle overloads with a proportional decrease in output water temperature; for example, a 20 percent overload would result in a 20 percent decrease in the rated 100°F rise temperature or an 80°F rise temperature or an 80°F rise, etc.

Apartments and motels experience two and three hour peak loads in the mornings and evenings; school and dormitory peak loads occur during shower hours; restaurant and hospital peak loads are during meal and clean-up times, etc. Peak load requirements are normally the most significant selection criteria.



Above: Installation at Cleveland Brown Stadium

For Commercial and Industrial Applications			
Laundries	Dormitories	Apartments	Hospitals
Car Wash	Rest Home	Motels	Restaurants
Schools	Industrial	Hotels	Food Processing



ASME



ASME



ETL Listed



ETL
Canadian Listed
(GAS & LPG Only)

Dimensions

B Series

INDOOR/OUTDOOR

MODEL	INPUT (BTU/HR)	OUTPUT (BTU/HR) ¹	H.P.	STANDARD OPERATING DATA			G.P.H. OUTPUT					INDOOR WEIGHT (LBS.)	OUTDOOR WEIGHT (LBS.)
				G.P.M.	HD. FT.	DEGREE RISE	20°F RISE	40°F RISE	60°F RISE	80°F RISE	100°F RISE		
B2G	200,000	160,000	4.8	18.7	5	18.6	960	480	320	240	192	175	225
B3G	300,000	240,000	7.0	18.7	6	27.9	1,140	720	480	360	288	200	250
B4G	420,000	336,000	10.0	18.7	7.5	39.0	2,016	1,008	672	504	403	250	300
B5G	500,000	400,000	12.0	18.7	12	46.5	2,400	1,200	800	600	480	300	350
B7G	700,000	560,000	17.0	38.3	8.3	31.9	3,360	1,680	1,120	840	672	450	500
B8G	800,000	640,000	19.0	38.3	8.3	36.4	3,840	1,920	1,280	960	768	450	500
B11G	1,100,000	880,000	26.0	38.3	13.5	50.1	5,280	2,640	1,760	1,320	1,056	525	600
B13G	1,300,000	1,040,000	31.0	38.3	23	59.2	6,240	3,120	2,080	1,560	1,248	675	750
B15G	1,500,000	1,200,000	36.0	38.3	29.5	68.3	7,200	3,600	2,400	1,800	1,440	700	775

¹ Boiler recovery rate @ 80% efficiency based on Mfg. Lab. Test.
G.P.H. Output based on circulation with storage tank.

INDOOR LOW TEMPERATURE

MODEL	INPUT (BTU/HR)	OUTPUT (BTU/HR) ¹	H.P.	STANDARD OPERATING DATA			G.P.H. OUTPUT					INDOOR WEIGHT (LBS.)
				G.P.M.	HD. FT.	DEGREE RISE	5°F RISE	10°F RISE	20°F RISE	30°F RISE	40°F RISE	
B2G	200,000	160,000	4.8	18.7	5	18.6	3,840	1,920	960	640	480	200
B3G	300,000	240,000	7.0	18.7	6	27.9	5,760	2,880	1,440	960	720	225
B4G	420,000	336,000	10.0	18.7	7.5	39.0	8,064	4,032	2,016	1,344	1,008	275
B5G	500,000	400,000	12.0	18.7	12	46.5	9,600	4,800	2,400	1,600	1,200	325
B7G	700,000	560,000	17.0	38.3	8.3	31.9	13,440	6,720	3,360	2,240	1,680	475
B8G	800,000	640,000	19.0	38.3	8.3	36.4	15,360	7,680	3,840	2,560	1,920	475
B11G	1,100,000	880,000	26.0	38.3	13.5	50.1	21,120	10,560	5,280	3,520	2,640	550
B13G	1,300,000	1,040,000	31.0	38.3	23	59.2	24,960	12,480	6,240	4,160	3,120	700
B15G	1,500,000	1,200,000	36.0	38.3	29.5	68.3	28,800	14,400	7,200	4,800	3,600	725

APPLICATION: POOL HEATERS

MODEL	INPUT (BTU/HR)	POOL AREA SQ.FT.	POOL VOLUME GALS.	POOL SIZE' W x L
B2GL	200,000	475	19,500	15' x 30'
B3GL	300,000	735	30,000	18' x 40'
B4GL	420,000	1,050	43,000	25' x 42'
B5GL	500,000	1,260	51,800	25' x 50'
B7GL	700,000	1,600	65,000	28' x 60'
B8GL	800,000	1,830	75,000	30' x 60'
B11GL	1,100,000	2,630	110,000	35' x 75'
B13GL	1,300,000	3,150	130,000	42' x 75'
B15GL	1,500,000	3,680	150,000	50' x 75'
(2) B11GL	2,200,000	5,250	215,000	50' x 105'
(2) B13GL	2,600,000	6,300	260,000	63' x 100'
(2) B15GL	3,000,000	7,350	300,000	75' x 100'
(3) B11GL	3,300,000	7,900	325,000	48' x 165'
(3) B13GL	3,900,000	9,500	390,000	57' x 165'
(3) B15GL	4,500,000	11,000	450,000	67' x 165'
(4) B13GL	5,200,000	12,600	520,000	75' x 165'

¹Based on average pool depth of 3 feet 6 inches. Heater capacities based on operation with natural gas.

Above sizing based on width x length of pool x 15 (BTU/sq.ft.) x 25°F temperature rise. Approximately 1°/per hour temperature rise. Calculations are figured to show maximum sizing for each model.

TYPICAL POOL HOOK-UP DIAGRAM

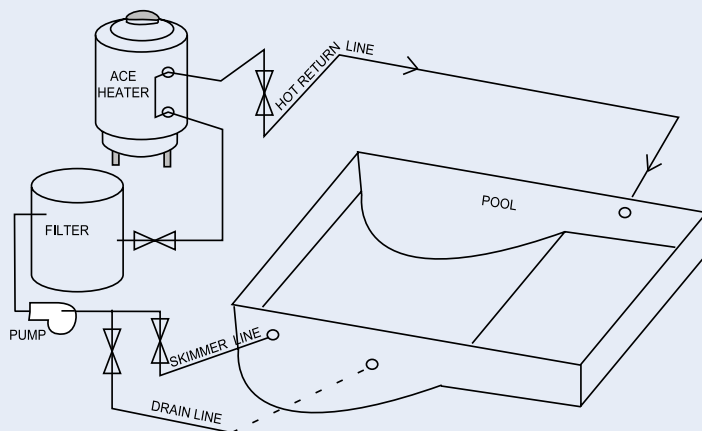

Condensing will occur during the combustion process when the combustion gases come in contact with cool heating surfaces of boilers and water heaters. Condensation will cause damage to all fired boilers and water heaters.

The moisture from condensation will cause incomplete combustion which will reduce the combustion efficiency and cause sooting of the boiler. Sooting will reduce the heat transfer efficiency and clog the flue gas passages disrupting the combustion process. On atmospheric fired boilers, clogged flue passages may cause flame roll out from the combustion chamber and a fire hazard.

Moisture in the flue gases from condensation will cause rusting of the boiler tubes and the boiler stack and also damage boiler refractory and insulation.

Condensation can be prevented in properly designed boiler and water heating systems by maintaining inlet water temperatures above the dew point. Dew point, depending upon the atmospheric pressure, temperature and humidity conditions, will normally occur when the water inlet temperature is in the 120°F to 130°F range. It is generally accepted therefore, that 140°F boiler water inlet temperature should be maintained to provide a small operating safety margin. Condensation damage can also be reduced by limiting cold start ups to once or twice a year. Night set back controls and delayed-system three way valves can minimize low temperature firing.

B Series

For low temperature applications such as water source heat pumps, low temperature heating systems, low temperature water heating application such as used in convalescent home, ACE HEATERS offers boiler and water heater “return loop blend” (RLB) packages. The RLB packages are furnished with manual valves for systems with relatively constant flow and temperature conditions. Failure to maintain 140°F inlet water temperature will void your boiler warranty.

For a main loop flow of 3,520 GPH, at a temperature rise of 30°F, select Model B11G from the table. (Note: Maximum main loop supply temperature is 200°F.)

For only main loop flow and temperature rise conditions, the boiler will heat a fraction of the main loop flow. The heated water will then be returned to the main loop where it will mix with unheated water to provide the desired loop temperature.

For inlet water temperatures below 140°F, some of the hot water exiting the boiler must be returned to the boiler water inlet to provide a blended inlet water temperature of 140°F or higher. This return-blend action is activated by closing the blend valve until the temperature at the boiler inlet reaches 140°F.



Ace Series Indoor Water Heaters Factory Assembly Line



Dimensions

INDOOR

MODEL	A BOILER DIA.	B BOILER HEIGHT	C OUTLET LOC.	D INLET LOC.	E PIPE LOC.	F O.A. HEIGHT
B2G	18	36	33	24	8	58 ¹ / ₄
B3G	20	38	34	24	8	62 ¹ / ₂
B4G	24	38	34	24	9	68 ¹ / ₄
B5G	24	42	38	24	9	72 ¹ / ₄
B7G	28	46	39	25	11	77 ¹ / ₄
B8G	28	46	39	25	16	77 ¹ / ₄
B11G	32	50	43	25	16	85 ¹ / ₂
B13G	35	52	45	25	16	91 ³ / ₄
B15G	35	54	48	25	16	93 ³ / ₄

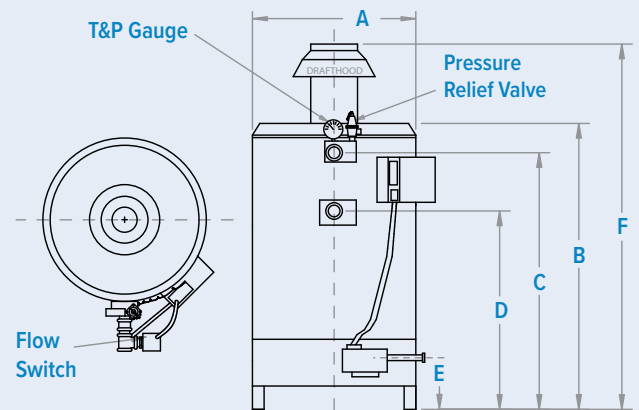

OUTDOOR

MODEL	A BOILER DIA.	B BOILER HEIGHT	C OUTLET LOC.	D INLET LOC.	E GAS PIPE SIZE
B2GO	18	46	38 ¹ / ₂	30	3/4
B3GO	20	50	41 ¹ / ₂	32	3/4
B4GO	24	50	41 ¹ / ₂	32	3/4
B5GO	24	54	45 ¹ / ₂	32	1
B7GO	28	56 ¹ / ₂	43	29	1
B8GO	28	56 ¹ / ₂	43	29	1 ¹ / ₄
B11GO	32	62 ¹ / ₂	49	31	1 ¹ / ₄
B13GO	35	65 ¹ / ₂	52	32	1 ¹ / ₄
B15GO	35	67 ¹ / ₂	54	32	1 ¹ / ₄

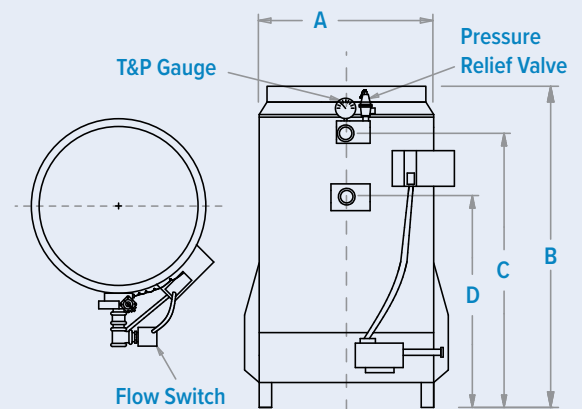

Dimensions

B Series

INDOOR LOW TEMPERATURE

MODEL	A BOILER DIA.	B BOILER HEIGHT	C OUTLET LOC.	D INLET LOC.	E O.A. HEIGHT
B2GL	18	36	33	24	58 ¹ / ₄
B3GL	20	38	34	24	62 ¹ / ₂
B4GL	24	38	34	24	68 ¹ / ₄
B5GL	24	42	38	24	72 ¹ / ₄
B7GL	28	46	39	25	77 ¹ / ₄
B8GL	28	46	39	25	77 ¹ / ₄
B11GL	32	50	43	25	85 ¹ / ₂
B13GL	35	52	45	25	91 ³ / ₄
B15GL	35	54	48	25	93 ³ / ₄



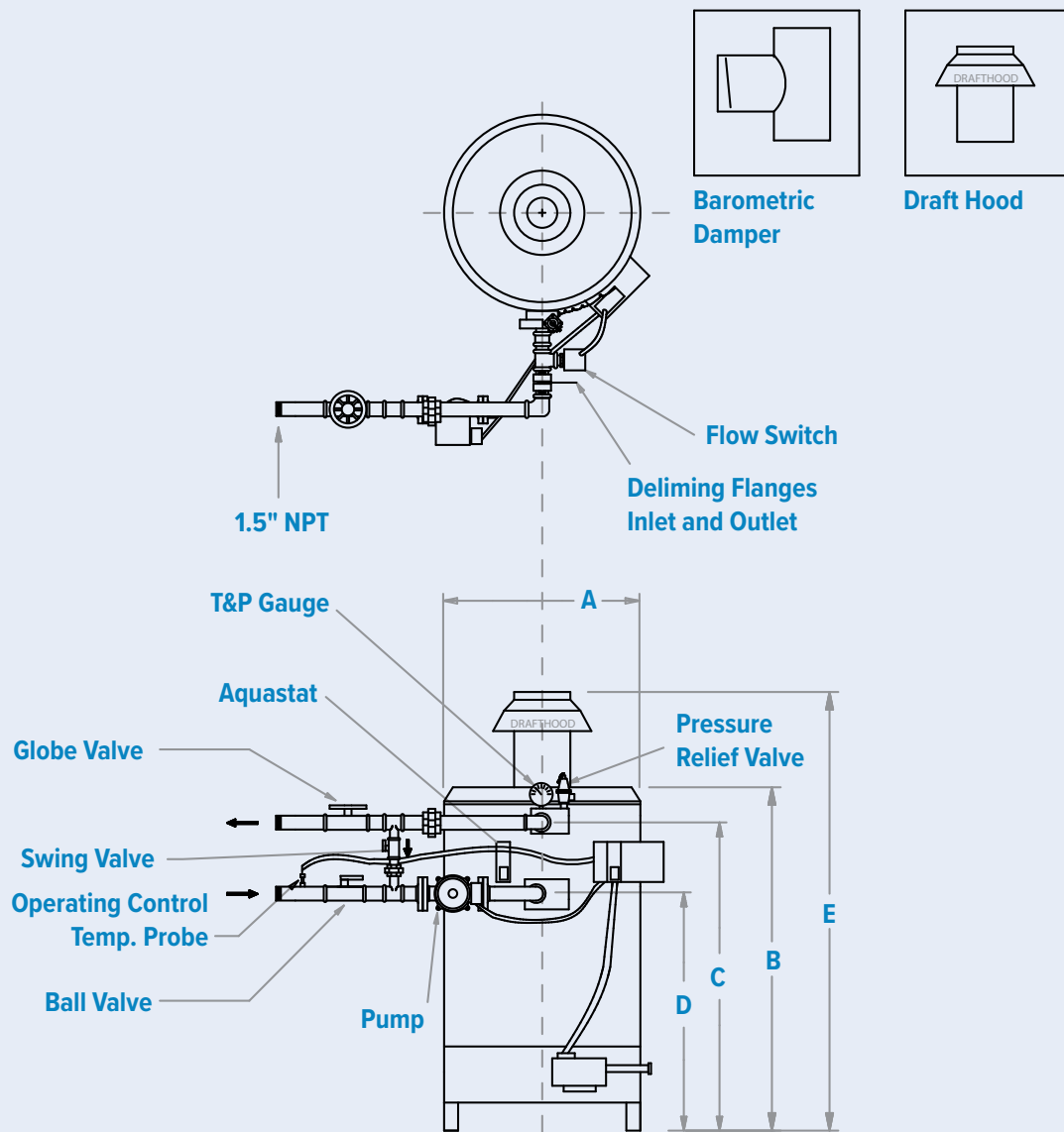

ASME



ASME



ETL Listed



ETL
Canadian Listed
(GAS & LPG Only)

B Series

Packaged Hot Water Systems



The Ace Series Packaged Hot Water systems offer pre-piped copper fin heaters with storage tanks to meet continuous load demands with trouble-free installation. They perform dependably and quietly, providing commercial, institutional, and industrial buildings with potable hot water. The even flow copper fin coils are designed to be energy efficient.

Features

- Sized for continuous and peak load requirements
- Compactly sized, minimum floor space required
- Low maintenance, easy to install
- All controls, electrical, gas and water connections including the electronic ignition system are located on the front for ease of operation and service



Standard Equipment

B Series Atmospheric Gas Fired Water Heater

- U.L. Listed for Natural Gas or Propane
- Coil built to ASME code
- Hi-Fin copper coil
- Electronic ignition standard on all units
- Flow switch
- CSD-1 control system
- Temperature-pressure gauges and relief valves on both heater(s) and tank
- Mirror finish stainless steel jacketing (see Water Heater Section for more details)

Storage Tanks

- Tank built to ASME code
- Glass-lined model SW storage tanks (125 PSIG)
- Standard selection of linings, 160°F maximum temperature (see Storage Tank Section for more details)

Packages

- All copper and bronze piping with two bronze water valves per package, and two delimiting flange cut-offs per heater
- Complete wiring of heater(s), controls and pumps
- Bronze circulating pump
- Base mounting of heaters on steel skid available (2 heaters or more)

Optional Equipment

Packages

- Stack sensor / pump delay
- Lead / Lag controls
- FM and IRI insurance codes
- Operating aquastat on tank
- Base mounting to include tank and heater(s)
- Jacketed and Insulated tank

Packaged Hot Water Systems

Ace Series packaged hot water systems are engineered to meet continuous load demands. Continuous output is the rated output of the heater. Peak load output is the rated output of the heater plus drawing upon the storage tank reserve capacity. Shorter peak load capacities, at higher output rates and longer peak loads at lower rates, can be handled by the Ace Package Hot Water Systems. In addition to peak load capacities the Ace Systems will handle overloads with a proportional decrease in output water temperature; for example, a 20 percent overload would result in a 20 percent decrease in the rated 100°F rise temperature or an 80°F rise temperature, etc. Apartments and motels experience two and three hour peak loads in the morning and evenings; school and dormitory

peak loads occur during shower hours; restaurant and hotels peak load are during meal and clean-up times; etc. Peak load requirements are normally the most significant selection criteria.

The Ace Series packaged hot water system is an automatic circulating type heater with a storage tank. The cold make up water enters the storage tank and mixes with hot water in the tank to raise the temperature of the water entering the heater to eliminate condensation in the heater. Return loop warm water is brought in at the suction side of the circulating pump to boost the blended water temperature entering the heater to 140°F and reduces the possibility of condensation. If the peak load fluctuations are not too large, a small storage tank may be used. Or the volume of water in the building hot water piping may be large enough to

Packaged Model Number:

P 2 - B 2 G - 4 2 5

- Tank size (in gallons)
- Heater size (B2G, B3G, etc.)
- Number of heaters:
 - = 1 Heater
 - 2 = 2 Heaters
 - 3 = 3 Heaters
- Packaged Water Heater

Certification

Packaged Hot Water System Listed by the E.T.L. as - Automatic Circulating Tank Type water heater, natural gas. Slightly lower ratings using propane gas. Also, approved as hot water boilers, Model B2G through B15G, for operation up to 240°F. All Ace Series heaters and boilers are built in accordance and are stamped with the ASME codes.

Limited Warranty

All Ace Series water heaters carry a 3 year warranty on coil and 1 year on controls. Owner warranty terms and registration shipped with each heater.

provide the blending and recirculation requirement. A larger storage tank should be used when very high short duration peak load conditions occur.

Automatic recirculation and blending are required to obtain the desired “gallons per hour output” at the needed temperature “rise.” The illustration shows the heater/boilers recirculating water and the blending with both make up and return water.

Refer to individual package product section for the recovery rate in the gallons per hour for a range of temperature rise for each heater/boiler model size.

By setting the operating aquastat for the desired output water temperature the heater/boiler will stay on until the temperature setting is reached. The heater/boiler standard output rating is 40°F to 140°F temperature “rise.” The equivalent water heating output for each of the temperature rises can be provided by the heater/boiler based upon the make up water and/or return water input temperature and the output aquastat temperature setting.

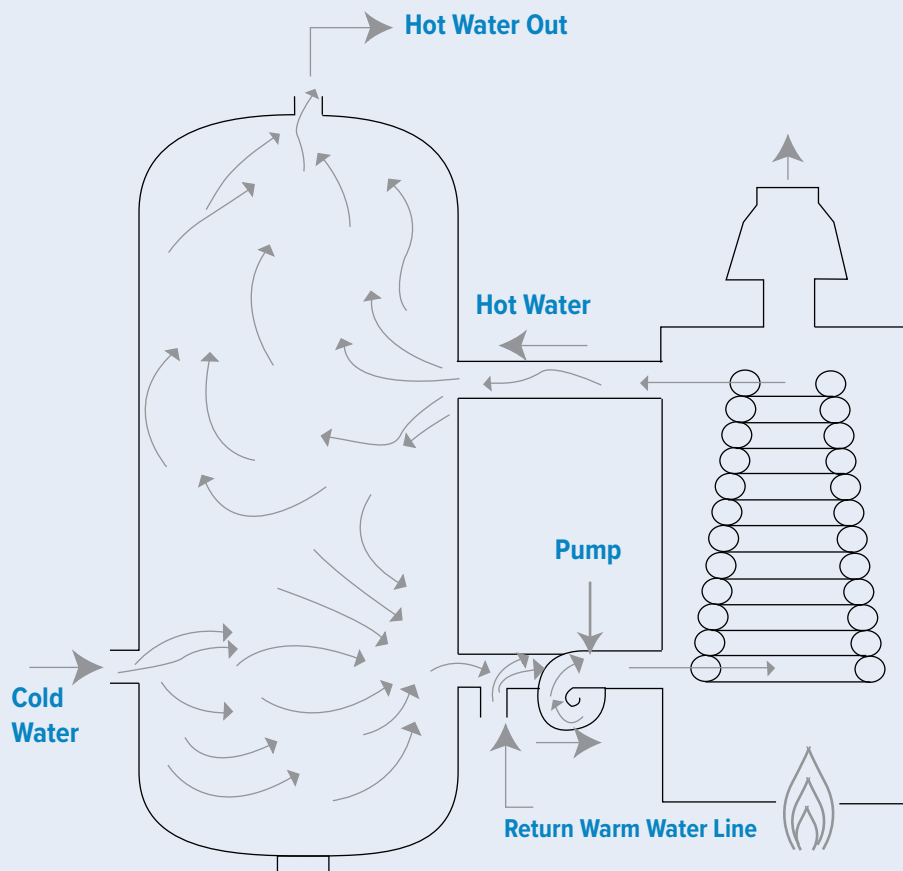

ASME

ASME

ETL Listed

ETL
Canadian Listed
(GAS & LPG Only)

Commercial Volume Water Heater Packages

Apartments	Motels	Hotels	Schools
Dormitories	Fraternities	Sororities	Convalescent
Hospitals	Clinics	Sanitariums	Rest Homes

PACKAGE MODEL #	GPH 100°F RISE	HEATER MODEL #	BTU OUTPUT X1000	STORAGE TANK MODEL #	PUMP SIZE	A HEATER DIA.	B HEATER HEIGHT	C OUTLET LOC.	D INLET LOC.	E GAS PIPE SIZE	H OAL	J OAH	K VENT DIA.
P_2-117	192	B2G	160	SW2404	1	18	36	33	24	3/4	58 1/4	71 1/2	6
P_3-117	288	B3G	240	SW2404	1	20	38	34	24	3/4	62 1/2	71 1/2	8
P_4-140	403	B4G	336	SW2405	1	24	38	34	24	3/4	68 1/4	83 1/2	10
P_5-190	480	B5G	400	SW3004	1	24	42	38	24	1	72 1/4	77	10
P_7-190	672	B7G	560	SW3004	1	28	46	39	25	1	77 1/4	77	12
P_8-190	768	B8G	640	SW3004	1	28	46	39	25	1 1/4	77 1/4	77	12
P_8-325	768	B8G	640	SW3605	1	28	46	39	25	1 1/4	77 1/4	90 1/2	12
P_11-325	1056	B11G	880	SW3605	1	32	50	43	25	1 1/4	85 1/2	90 1/2	14
P_13-325	1248	B13G	1040	SW3605	1 1/2	35	52	45	25	1 1/4	91 3/4	90 1/2	16
P_15-375	1440	B15G	1200	SW3606	1 1/2	35	54	48	25	1 1/4	93 3/4	102 1/2	16

SINGLE HEATER

PACKAGE MODEL NUMBER	INPUT (BTU/HR)	GPH OUTPUT 100°F (40° - 140°F)				APTS # OF UNITS	MOTELS # OF BATHS	MOTELS TOURISTS # OF BATHS	HOSPITALS # OF BEDS	FRATERNITY HOUSES # OF OCCUPANTS	DIMENSIONS' W x OAL x OAH	SHIPPING WEIGHT (LBS.)
		CONTINUOUS	PEAK LOAD									
			1 HOUR	2 HOUR	3 HOUR							
P-2-117	200,000	192	282	236	220	15	15	17	17	13	26 x 58 1/4 x 71 1/2	510
P-3-117	300,000	288	382	336	320	25	25	28	28	20	26 x 62 1/2 x 71 1/2	540
P-4-140	420,000	403	512	456	437	40	35	40	43	33	26 x 68 1/4 x 83 1/2	632
P-5-190	500,000	480	632	556	530	50	45	50	55	40	30 x 72 1/4 x 77	730
P-7-190	700,000	672	824	748	723	68	52	60	68	52	30 x 77 1/4 x 77	880
P-8-190	800,000	768	920	844	818	79	63	68	79	59	30 x 77 1/4 x 77	880
P-8-325	800,000	768	1028	898	855	105	78	84	89	68	30 x 77 1/4 x 90 1/2	1070
P-11-325	1,100,000	1056	1236	1146	1116	155	93	103	108	88	34 x 85 1/2 x 90 1/2	1145
P-13-325	1,300,000	1248	1508	1378	1335	204	112	122	128	102	37 x 91 3/4 x 90 1/2	1282
P-15-375	1,500,000	1440	1744	1592	1541	250	150	165	170	120	37 x 93 3/4 x 102 1/2	1391

MULTIPLE HEATERS

P2-8-425	1,600,000	1540	1876	1706	1646	314	188	209	220	173	40 x 77 1/4 x 114 1/2	1663
P2-11-460	2,200,000	2110	2492	2302	2239	362	222	243	258	196	44 x 85 1/2 x 97 1/2	2060
P2-13-530	2,600,000	2500	2920	3344	2637	408	255	281	306	235	48 x 91 3/4 x 109 1/2	2060
P2-15-700	3,000,000	2880	3440	3160	3067	550	320	350	400	290	48 x 93 3/4 x 111	2445
P3-13-795	3,900,000	3750	4380	4062	3956	612	408	449	460	358	48 x 91 3/4 x 123	3534
P3-15-980	4,500,000	4320	5120	4720	4587	725	435	485	550	400	48 x 93 3/4 x 124	4080

Sizing recommendations are for maximum demands experienced under standard conditions - normal installation. Sizing is based upon 3 GPM showers (one per unit), 40°F inlet to 140°F outlet water, a hot water return line (3 to 5 GPM flow), no dishwashers and no automatic washers.

Dishwasher - Add approximately 10 to 12 GPH heater recovery for each dishwasher.

Automatic washer - Add 40 to 50 GPH heater recovery for each standard size washers. Note: some standard make washers take up to 60 GPH.

For 180°F sanitizing water for dishwasher or laundry using a cement lined tank, increase GPH addition by 1.3 multiplier and provide for mixing valve.

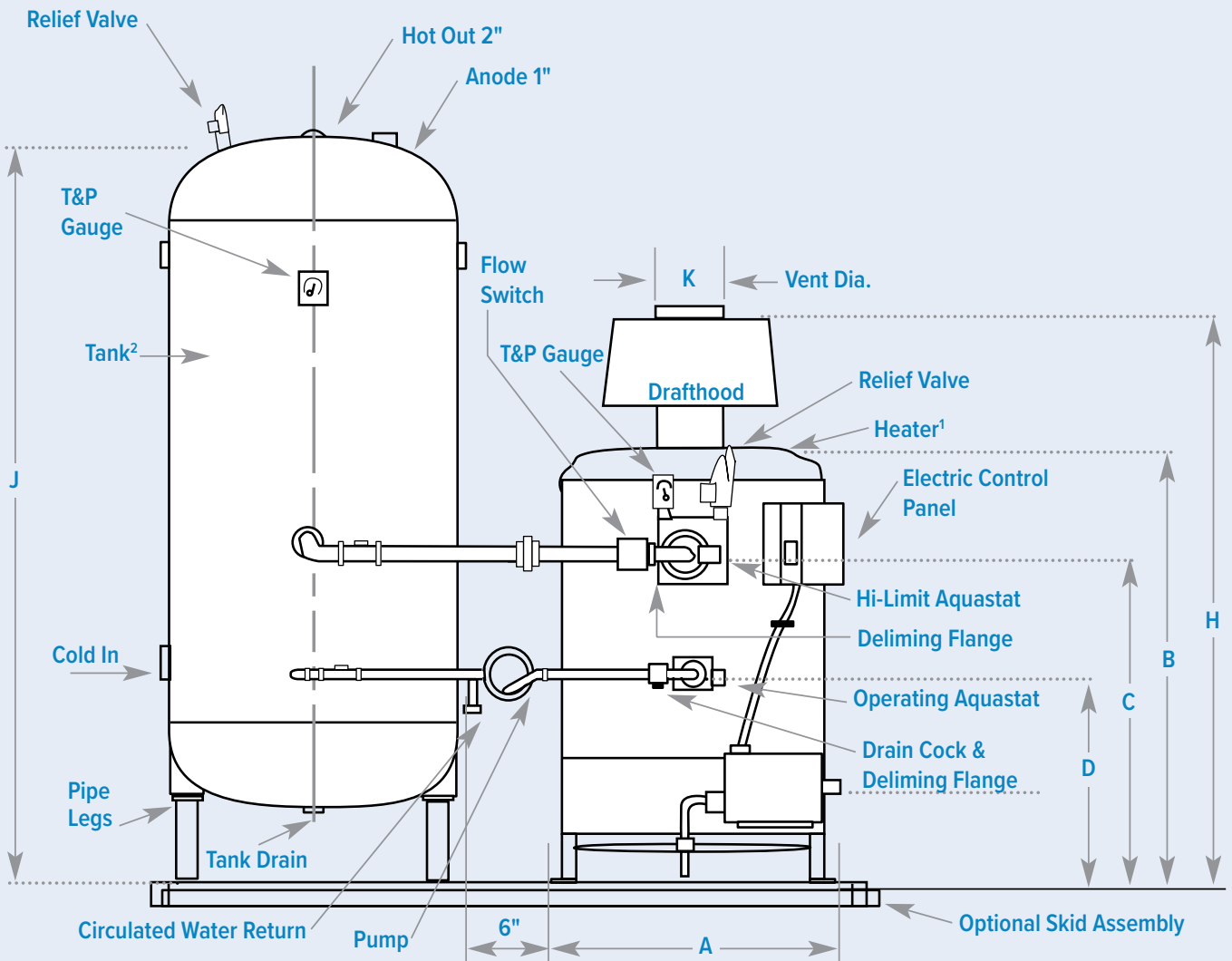

ASME



ASME



ETL Listed



ETL
Canadian Listed
(GAS & LPG Only)

Commercial Volume Water Heater Packages for Laundry

Water Heater Coin Laundry Sizing Guide

Water heater and storage tank sizing for peak load hot water requirements based upon the following industry standards:

1. Washers will run 1-1/2 cycles/hr (allowances for loading & unloading).
2. Allows for 80% load factor. (cold water washes, delays between washes, down time, etc.)
3. Uses industry standard washer hot water usage per wash cycle.
4. Quantity and washer size mix for the laundry.

MACHINE HOT WATER USAGE

	Hot Water Draw per Cycle (HWD)	Factored Hot Water Draw/Cycle (FHWD) (=HWD x 1.5 x 0.8)
Top Loaders	13	15.6
18 lb.	15	18.0
25 lb.	18	21.6
35 lb.	28	33.6
50 lb.	38	45.6

Store Sizing Examples

P5-425*

20 Machines	Qty.	FHWD	GPH Req'd
Top Ldr's	12	15.6	187
18 lb.	1	18.0	18
25 lb.	1	21.6	22
35 lb.	5	33.6	168
50 lb.	1	45.6	46
Total	20		440

P7-325*

30 Machines	Qty.	FHWD	GPH Req'd
Top Ldr's	18	15.6	281
18 lb.	1	18.0	18
25 lb.	1	21.6	22
35 lb.	9	33.6	302
50 lb.	1	45.6	46
Total	30		668

P11-375*

40 Machines	Qty.	FHWD	GPH Req'd
Top Ldr's	26	15.6	406
18 lb.	1	18.0	18
25 lb.	2	21.6	43
35 lb.	9	33.6	302
50 lb.	2	45.6	91
Total	30		860

P13-425*

20 Machines	Qty.	FHWD	GPH Req'd
Top Ldr's	32	15.6	499
18 lb.	1	18.0	18
25 lb.	2	21.6	43
35 lb.	13	33.6	437
50 lb.	2	45.6	91
Total	50		1088

P15-475*

30 Machines	Qty.	FHWD	GPH Req'd
Top Ldr's	36	15.6	281
18 lb.	1	18.0	18
25 lb.	3	21.6	22
35 lb.	17	33.6	302
50 lb.	3	45.6	46
Total	60		668

P2-11-475*

40 Machines	Qty.	FHWD	GPH Req'd
Top Ldr's	38	15.6	593
18 lb.	2	18.0	36
25 lb.	3	21.6	65
35 lb.	24	33.6	806
50 lb.	3	45.6	137
Total	70		1637

P2-11-475*

20 Machines	Qty.	FHWD	GPH Req'd
Top Ldr's	42	15.6	655
18 lb.	2	18.0	36
25 lb.	3	21.6	65
35 lb.	30	33.6	1008
50 lb.	3	45.6	137
Total	80		1901

P2-13-530*

30 Machines	Qty.	FHWD	GPH Req'd
Top Ldr's	45	15.6	702
18 lb.	2	18.0	36
25 lb.	4	21.6	86
35 lb.	35	33.6	1176
50 lb.	4	45.6	182
Total	90		2183

P2-13-530*

40 Machines	Qty.	FHWD	GPH Req'd
Top Ldr's	50	15.6	780
18 lb.	2	18.0	36
25 lb.	4	21.6	86
35 lb.	39	33.6	1310
50 lb.	5	45.6	228
Total	100		2441

The above examples should be adjusted to fit the machine quantities, draws, duty cycle, etc. for store.

*Recommended Models.

SELECT HEATER PACKAGE PER TOTAL STORE GPH REQUIRED							
PACKAGE MODEL #	INPUT (BTU/HR)	OUTPUT (BTU/HR)	GPH 100°F RISE	STORAGE TANK MODEL #	TANK GAL.	PUMP SIZE	SHIPPING WEIGHT (LBS.)
GAS-FIRED SINGLE HEATER PACKAGE UNITS							
P_3-190	300,000	240,000	288	SW3004	190	1	633
P_4-190	420,000	336,000	403	SW3004	190	1	680
P_5-225	500,000	400,000	480	SW3005	225	1	789
P_7-325	700,000	560,000	672	SW3605	325	1	1070
P_8-375	800,000	640,000	768	SW3606	375	1	1141
P_11-375	1,100,000	880,000	1056	SW3606	375	1	1216
P_13-425	1,300,000	1,040,000	1248	SW3607	425	1 1/2	1425
P_15-475	1,500,000	1,200,000	1440	SW3608	475	1 1/2	1534
P_15-460	1,500,000	1,200,000	1440	SW4205	460	1 1/2	1710
GAS-FIRED MULTIPLE HEATER PACKAGE UNITS							
P2-4-275	800,000	480,000	810	SW3604	275	1 1/2	1049
P2-5-325	1,000,000	800,000	960	SW3605	325	1 1/2	1220
P2-7-375	1,400,000	1,120,000	1344	SW3606	375	1 1/2	1591
P2-8-425	1,600,000	1,280,000	1540	SW3607	425	1 1/2	1663
P2-11-475	2,100,000	1,760,000	2112	SW3608	475	1 1/2	1884
P2-13-530	2,600,000	2,080,000	2500	SW4206	530	2	2521

Washer units based upon maximum of 80% of the washer operating at one time.

Heater recovery rate based upon GPH 40°F to 140°F, 100°F rise rated 80% heater efficiency based upon Ace Series lab tests. Ace Series Heater working pressure 160#.

Altitude: Derate heater output by 4% for each 1000 feet above sea level.

Certification

Packaged Hot Water System Listed by the E.T.L. as - Automatic Circulating Tank Type water heater, natural gas. Slightly lower ratings using propane gas. Also, approved as hot water boilers, Model B2G through B15G, for operation up to 240°F. All Ace Series heaters and boilers are built in accordance and are stamped with the ASME codes.

Limited Warranty

All Ace Series water heaters carry a 3 year warranty on coil and 1 year on controls. Owner warranty terms and registration shipped with each heater.



Ace Heaters
130 Klug Circle
Corona, CA 92880
United States

(951) 738-2230
info@aceheaters.com
www.aceheaters.com