



Mini-Pack™ Semi-Instantaneous Water Heaters

Steam-to-Water or Water-to-Water Application

Mini-Pack Semi-Instantaneous Water Heaters

Steam-to-Water or Water-to-Water Application



The Ace Series Mini-Pack semi-instantaneous water heater is dependable and quiet, and provides commercial and institutional buildings with potable hot water. Close temperature controls, outstanding thermal efficiency, high quality ASME coded construction, and minimum floor space requirement makes the Mini-Pack one of our best selling products.

Features

- Close temperature controls with $\pm 4^{\circ}\text{F}$ at heater hot water outlet under normal operating conditions
- Solid rust-free stainless steel construction on the entire domestic water side and standard stainless steel mirror finish jacket
- Compactly sized requiring minimum space for installation, with vertical or horizontal heater choice
- Tube bundle readily accessible without removing shell or foundation for all single wall models; recommended horizontal mounting of double wall due to coil length
- Standard sizes cover hot water output from 5 to 650 GPM simplifying size selection and layout
- Quality components for high performance



Standard Equipment

Shell & Tube Bundle

- ASME Section VIII Division I vessel stamped for 150 psig design working pressure (MAWP).
- National Board registered
- Vertical or horizontal model with solid 316L stainless steel construction and 304L stainless steel fittings
- Steel vertical stand
- SB-75 seamless copper U-tube
- 304 stainless steel tube sheet

Controls

- Electric, Pneumatic and Pilot operated control valve for steam
- Electric and Pneumatic control valve for water
- 150 psig ASME pressure relief valve
- High limit aquastat
- Safety solenoid valve
- NEMA 1 control panel
- Control voltage 120v/1ph/60Hz, 10 amps
- Temperature gauge
- 1/25 HP recirculator pump
- Condensate orifice trap and steam strainer (for steam models)

Optional Equipment

Shell & Tube Bundle

- Horizontal model available with or without rack
- Double wall copper or cupro-nickel (90/10) tubing
- Single wall cupro-nickel (90/10) or 316L stainless steel tubing
- 250 psig shell and tube design working pressure
- 400 psig tube design working pressure (for HTW and HPS)
- Heat-treated shell for high-chloride application

Support

- Steel horizontal rack for 1 or 2 Mini-Pack
- Seismic support

Controls

- Electric, pneumatic water valves or pilot operated for steam
- Double safety solenoid dump valve
- Temperature & pressure gauge
- Dual valves setup: 1/3 and 2/3 pneumatic control
- Building automation relays
- T&P steam trap
- Alarm bell with silencer switch

Operating Controls

- Digital panel¹ (standard on electric)
- Remote Setpoint panel¹
- Building Automation panel¹
- Ace Communication Gateway¹

Digital Panel

Uses microprocessor based PID loop controller with RTD temperature sensor. Controller includes digital outlet temperature readout on two line/four button user interface, auto tuning, manual output control, high/low deviation alarm, 4-20mA outlet temperature feedback signal and keylock functions.

¹For pneumatic and electric control valve only.

Remote Setpoint Panel

Digital panel with operating control capable of receiving 4-20mA control signal to adjust the setpoint and high temperature alarm setpoint. Used with Building Management System (BMS) or outdoor reset control.

Building Automation Panel

RS-485 Modbus Communication enabled digital panel can be used to communicate between Building Management System and/or PLC. It can be used to read and write setpoint temperature, firing rate and PID parameters of the unit. Can be tied in to LonWorks and BACnet system through gateway provided from factory or by others.

ACE Communication Gateway

Standalone module is designed to allow Modbus enabled ACE products to interface to a customer's BACnet, Johnson N2 or LonWorks based Building Automation System.

	Standard Control	Digital Control	BMS	BMS with Gateway	Remote Set Point
Pilot	✓	✗	✗	✗	✗
Pneumatic	✓	○	○	○	○
Electric	✗	✓	*	○	○

✓ Available ✗ Not Available ○ Optional * Modbus



The **Mini-Pack** temperature control system keeps the heated water within four degrees of the selected temperature. This close control is accomplished by placing the temperature control element directly in the constant flow path of the water leaving the heating surface making so-called “anticipator” devices unnecessary. After the water passes over the control element it enters a tempering chamber between the heating surface and the water outlet.

Another essential part of the temperature control system is the integral circulator. This small pump (1/25 HP) constantly recirculates a portion of the heated water to the cold water inlet making “the total volume of the heater” a tempering chamber. Also eliminates any overheated water pockets caused by control valve lag when hot water demand is suddenly reduced. The pump can also be used to provide recirculation of the water from the fixtures through a tee fitting that is provided with the package. When the hot water return system requires greater recirculation the integral pump size can be pre-selected to provide the duty.

The Mini-Pack features total rust free construction with austenitic stainless steel and copper for all domestic water contact surfaces, providing high quality, low maintenance and an extremely cost-effective domestic water heating package. Non-metallic PTFE baffles are used to prevent tube damage.

The vertical Mini-Pack semi-instantaneous heater saves floor space, is simple to install and very easy to service and maintain. The vertical unit also provides complete drainage of condensate. Universal mounting brackets allow the Mini-Pack to be mounted in the horizontal position.

Mini-Pack Model Number:

SI - V - 8L - SW - S E 150

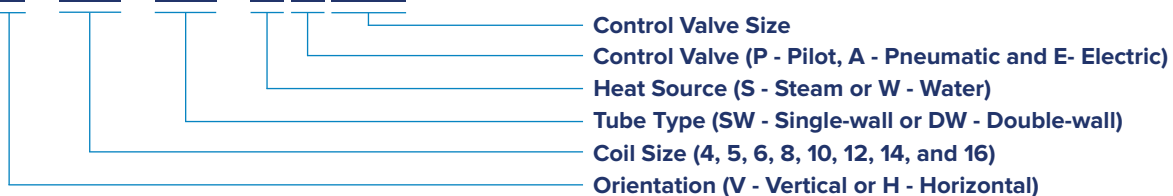

ASME

Features Diagram

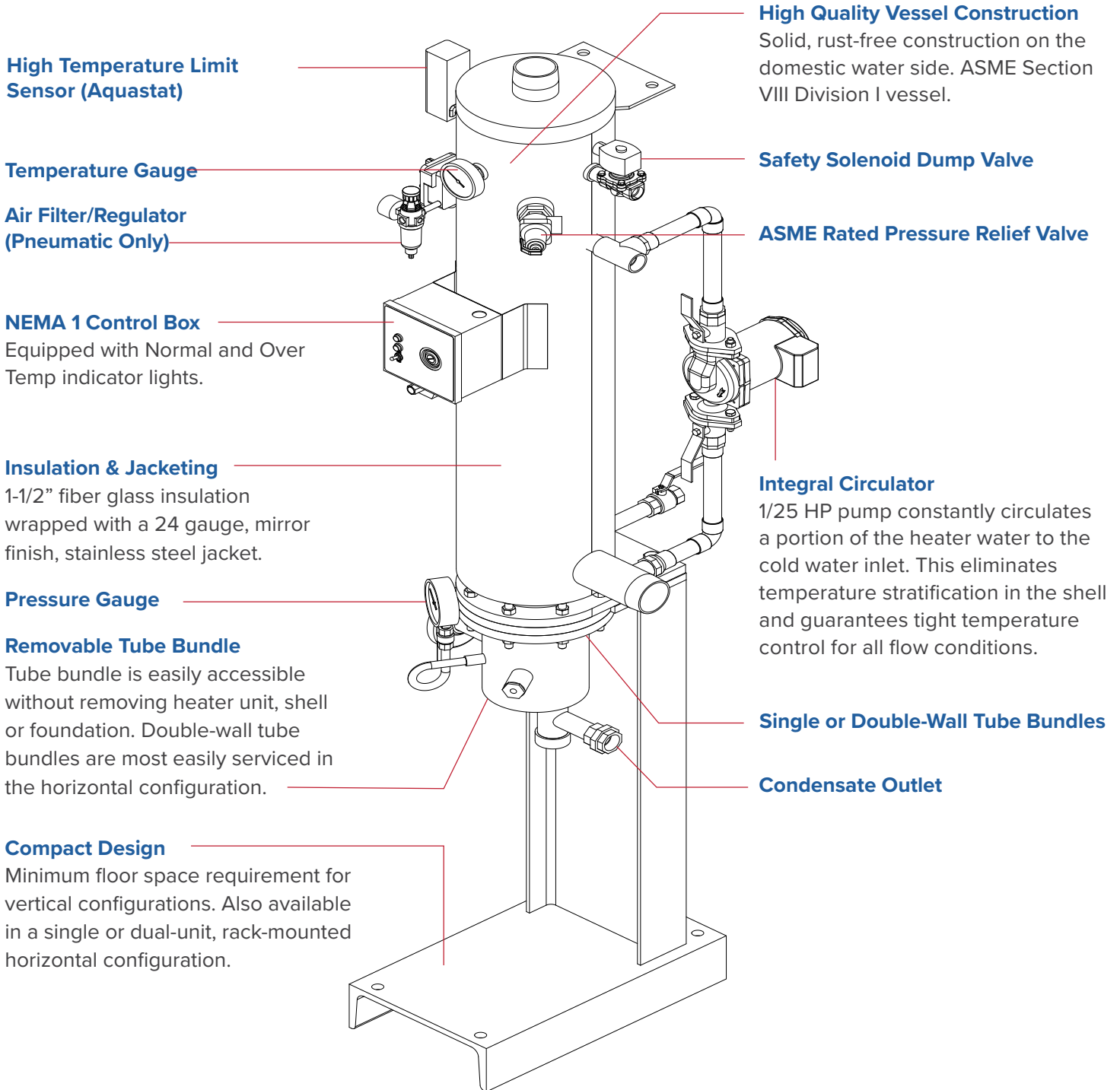

The Mini-Pack Advantages

Condensing Design – Sub-Cooled Condensate

Sub-cooling condensate maximizes the heat transfer efficiency of a heat exchanger. By using a condensing design, the Mini-Pack condenses steam in the tubes and cools condensate well below its flash temperature. This is achieved by simultaneously flowing entering cold water across the tubes carrying exiting condensate while using an orifice to restrict condensate drainage. Depending on the load, exiting condensate temperatures are typically 10-15 degrees higher than the exiting domestic hot water temperature which negates the need for a steam trap or flash tank.

Several benefits are realized from sub-cooling condensate:

- Sub-cooling can increase efficiency by as much as 25% which results in less steam required to heat the same GPM.
- No steam trap means no possibility for steam trap failure
- Heat typically lost to flash heats the domestic water instead of being lost
- in the condensate receiver or flash tank.
- Mechanical spaces are much cooler.
- Pumping cooler condensate greatly extends the life of pumps.

Heavy Wall Heat Exchanger Tubes

The Ace Series Mini-Pack uses heavy duty, 0.049" wall copper heat exchanger tubes... twice the wall thickness as tubes used by other leading water heater manufacturers. Thicker tube walls increase the longevity of the heat exchanger and provide improved efficiency. Thin wall tube bundles cost less, but can result in premature failure and high replacement cost. 0.049" tubing can last up to 25 to 30 years. 0.049" wall seamless SB75 copper tubing is standard on Ace Series Mini-Pack packages.

Double Solenoid High Temperature Safety Systems

The double solenoid system adds safety and guards against scalding. At a pre-determined high temperature setpoint, the system provides annunciation to the EMS system before a dangerous condition develops or the domestic hot water loop cools down. The system discharges at a lower temperature before the relief valve discharges (at 210° F). This safety system is optional on Ace Series Mini-Pack and storage water heater packages.

Extended Non-Prorated Warranty

The Ace Series Mini-Pack offers a factory extended, 10-year (or 10/20-year), non-prorated warranty that includes all wetted components (shell, heat exchanger tube sheet, etc).

The Ace Series Mini-Pack offers a factory extended, 10-year (or 10/20-year), non-prorated warranty that includes all wetted components (shell, heat exchanger tube sheet, etc).

Steam-To-Water Mini-Pack

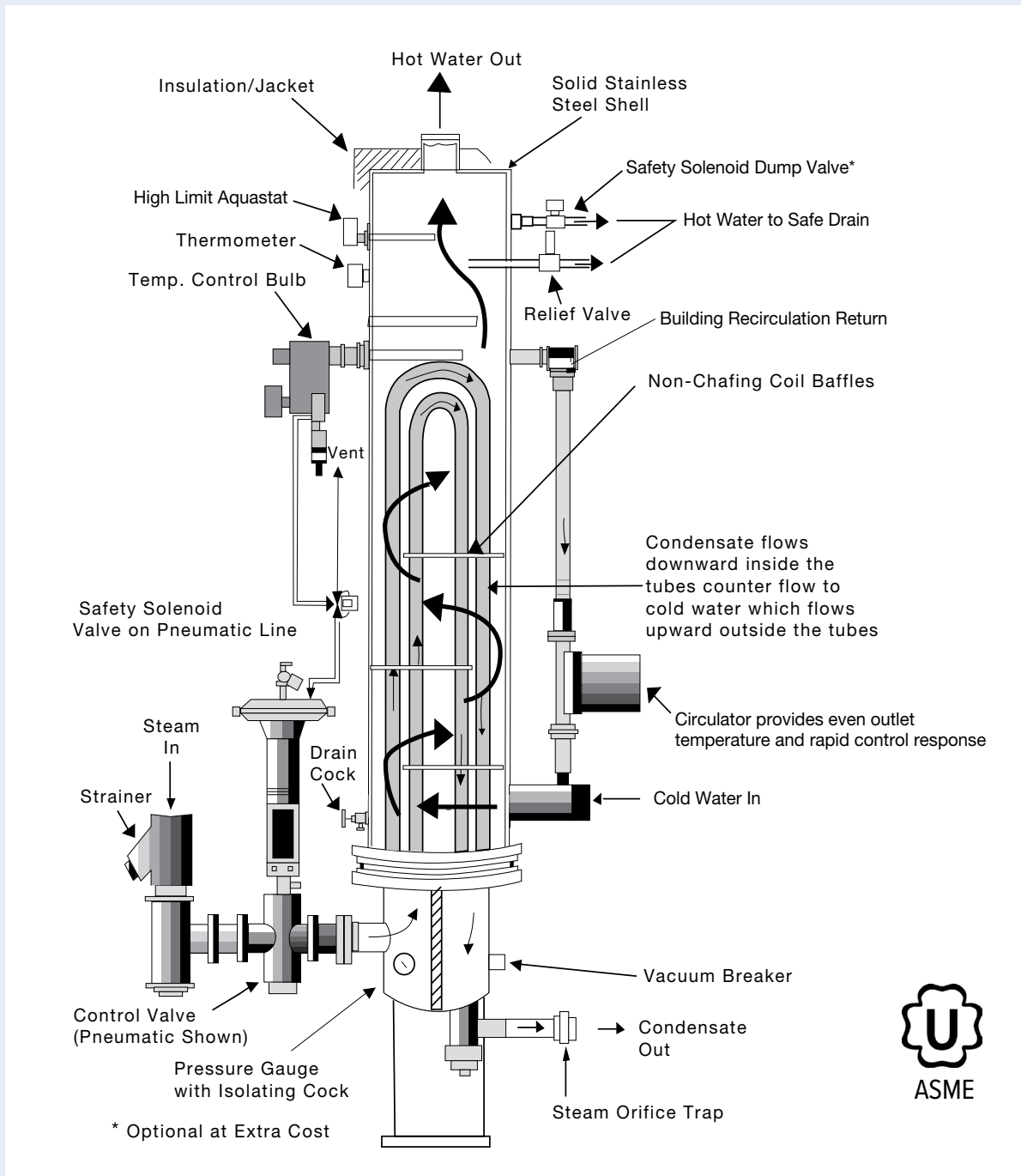

Mini-Pack Features

Construction

All semi-instantaneous water heaters must have non-ferrous shell construction to accommodate rust-free domestic, potable water. The Mini-Pack shell construction is unlined 316L stainless steel. Other leading manufacturers use a carbon steel shell with a thin copper lining on the water side. Liners are problematic because they can separate or split. Such failure exposes domestic water to carbon steel and can result in rusty, discolored, and contaminated water. Conversely, unlined shells are trouble-free. The Ace Series Mini-Pack unlined 316L stainless steel shell construction has no equal in the industry and is far superior to a copper-lined, carbon steel shell.

Design Versatility

The Ace Series Mini-Pack is ideal for small mechanical spaces. The Mini-Pack unit is available in a variety of configurations including vertical and horizontal, and single or double wall tubes. Horizontal units are preferred where headroom is a constraint. In the horizontal configuration, dual units can be stacked to minimize required floor space and reduce installation cost. If the condensate line is too high, the horizontal unit will enable gravity discharge of condensate and eliminate the need for a condensate receiver and pumpset. The vertical configuration has an extremely small footprint and does not require significant headroom clearance for servicing.

Temperature Control

There are two basic types of temperature controls used on semi-instantaneous water heaters: active systems (with a pump) and passive systems (without a pump). Both designs are characterized as 'anticipatory feed-forward' type temperature control systems and will control +/- 4°F at 'normal load variations'. The Mini-Pack uses an active system which uses a 1/25 HP, all bronze circulator to maintain constant flow over the temperature sensing element. This ensures fast response and tight temperature control at all load profiles. Passive systems rely on the differential pressure of the water flowing over the heat exchange surface and can save the cost of operating the small circulator. However, they cannot control temperature as well as pumped systems can at low flow conditions. With a pumped system, temperature control is very tight at all load profiles. The Mini-Pack temperature control system is simple, fast and accurate.



Serviceability

Servicing the Mini-Pack is fast, easy, and inexpensive. Parts are reasonably priced and readily available. The O & M manual outlines respective part numbers for each accessory manufacturer. All of the Mini-Pack accessories are readily available from local plumbing supply houses. In addition, the Mini-Pack is designed to be completely serviced in place without an overhead clearance requirement or the need to lay the unit horizontally. On single-wall vertical units, enough clearance exists under the stand to completely remove the heat exchanger.

Health Issues (i.e. Legionella)

The three conditions that must be present to promote the growth of the Legionella organism are:

- Host (usually in the form of scale)
- Low velocity
- Water temperatures between 68°F - 122°F.

The Ace Series Mini-Pack is designed to keep the shell side domestic water in constant circulation via the 1/25 HP circulator. This keeps the entire volume of water in the shell at

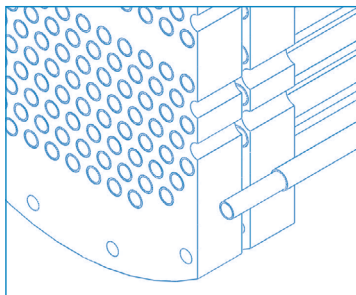

set-point temperature and eliminates temperature stratification common in the designs of our leading competitors. Most importantly, the Mini-Pack design eliminates the proliferation of Legionella bacterium by maintaining safe water temperatures and higher water velocities and minimizing scale formation.

Conclusion

The Ace Series Mini-Pack water heater has been tested and used for more than two decades in demanding, high volume water heating applications. It is a proven design that is simple, efficient, and trouble-free and offers building owners and maintenance personnel numerous end-user features and benefits. Specifying the Ace Series Mini-Pack water heater combines the highest levels of quality, efficiency, and safety with a long lasting, cost-effective design that is inexpensive to operate and easy to service.

Dimensions

Single-Wall / Steam-to-Water Vertical

MODEL	Height A	Width B	Depth C	SHIPPING WEIGHT (LBS.)
SI-V-4-SW-Sxx	83	40		350
SI-V-5-SW-Sxx	69 3/4	33 3/4		400
SI-V-6-SW-Sxx	86	42		500
SI-V-8-SW-Sxx	75 1/2	36 1/2		600
SI-V-8L-SW-Sxx	88 1/2	43 1/2		650
SI-V-10-SW-Sxx	79 1/2	38 3/4		900
SI-V-10L-SW-Sxx	92 1/2	45 3/4		950
SI-V-12-SW-Sxx	83 1/2	41 3/4		1,125
SI-V-12L-SW-Sxx	107 1/2	53 3/4		1,175
SI-V-14-SW-Sxx	98 1/2	48 3/4		1,700
SI-V-14L-SW-Sxx	128 1/2	63 3/4		1,800
SI-V-16-SW-Sxx	122	60 3/4		2,200
SI-V-16L-SW-Sxx	150	74 3/4		2,350

All dimensions in inches. Dimensions are subject to change.
See Page 14 for complete model number schema.
¹Connections 4" IPS and above 150# ANSI FLG

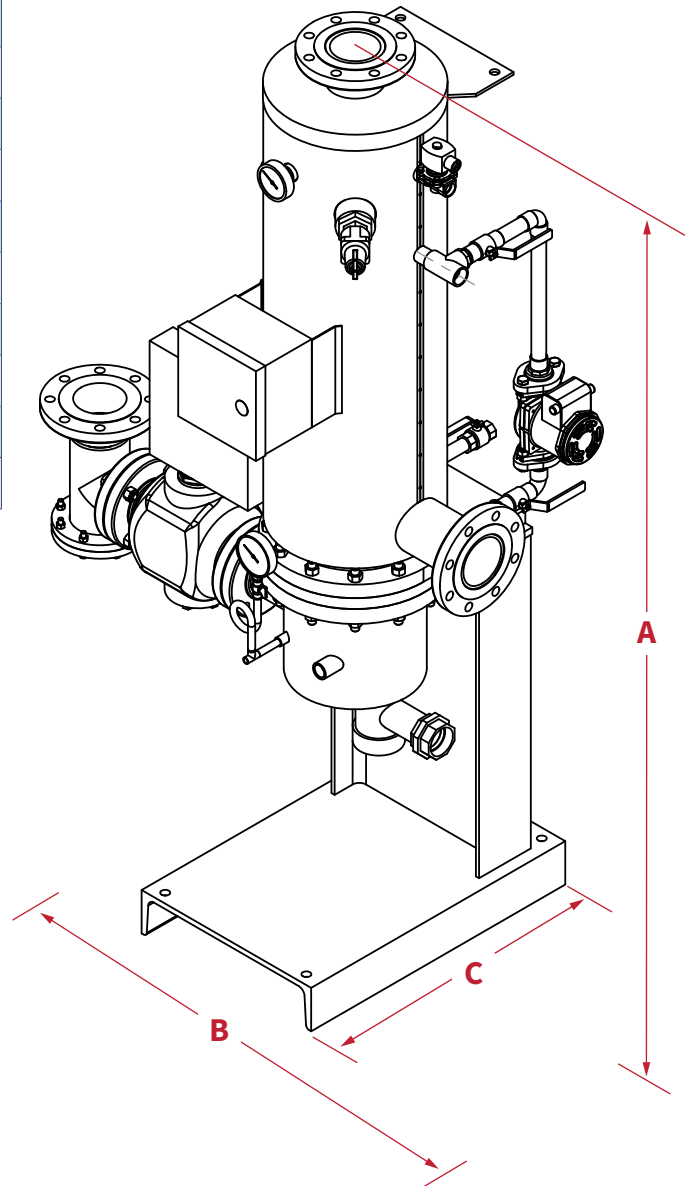
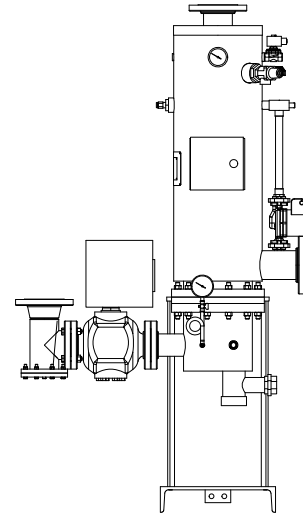

Dimensions

Single-Wall / Steam-to-Water

Horizontal

MODEL	Height A	Width B	Depth C	SHIPPING WEIGHT (LBS.)
SI-H-4-SW-Sxx	56 1/4	13 1/4		300
SI-H-5-SW-Sxx	49 1/4	13 1/4		350
SI-H-6-SW-Sxx	57 3/4	13 3/4		450
SI-H-8-SW-Sxx	54 1/4	15 1/4		550
SI-H-8L-SW-Sxx	60 1/4	15 1/4		600
SI-H-10-SW-Sxx	57 1/2	16 3/4		850
SI-H-10L-SW-Sxx	63 1/2	16 3/4		900
SI-H-12-SW-Sxx	64 1/2	23		1,075
SI-H-12L-SW-xx	76 1/2	23		1,125
SI-H-14-SW-Sxx	76 1/4	26 3/4		1,650
SI-H-14L-SW-Sxx	91 1/4	26 3/4		1,750
SI-H-16-SW-Sxx	91 3/4	30 3/4		2,150
SI-H-16L-SW-Sxx	105 3/4	30 3/4		2,300

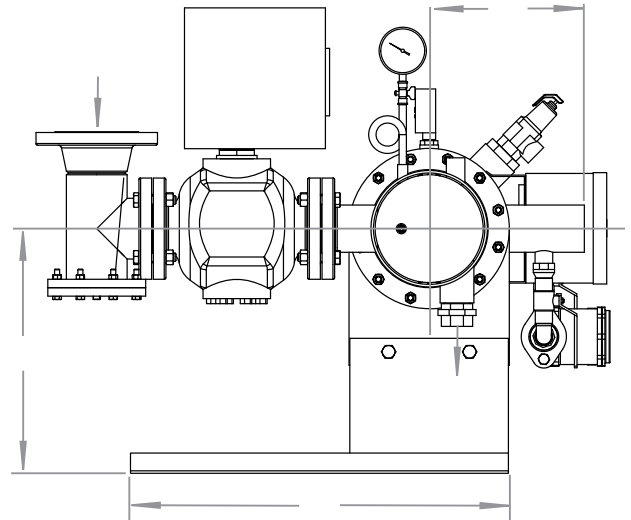

All dimensions in inches. Dimensions are subject to change.
 See Page 14 for complete model number schema
¹Connections 4" IPS and above 150# ANSI FLG

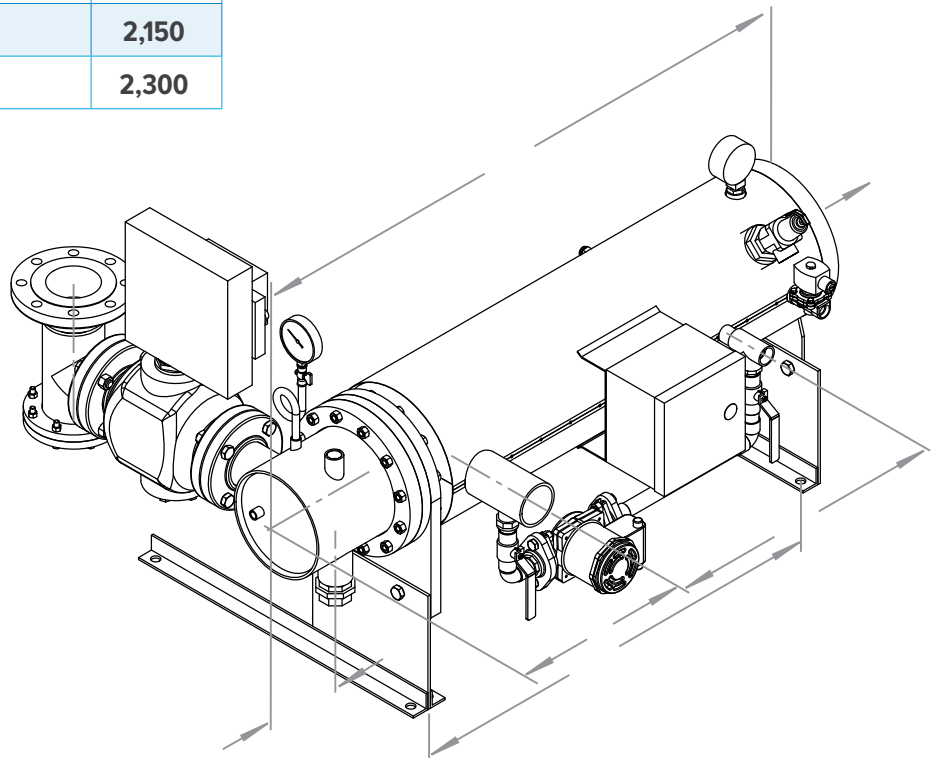

Dimensions

Double-Wall / Steam-to-Water Vertical

VERTICAL

Double-Wall Steam-to-Water

VERTICAL

MODEL	A	B	C	SHIPPING WEIGHT (LBS.)
SI-V-5-DW-Sxx	98 1/4	27 1/2	55	400
SI-V-6-DW-Sxx	102	30 3/4	54 1/2	500
SI-V-8-DW-Sxx	98 3/4	31 1/2	55 1/4	600
SI-V-10-DW-Sxx	105 1/2	35 3/4	56 1/2	1,000
SI-V-12-DW-Sxx	110 1/2	39 1/4	55	1,300
SI-V-14-DW-Sxx	122	41 3/4	63	1,900
SI-V-16-DW-Sxx	128 1/2	44	66 3/4	2,450

All dimensions in inches. Dimensions are subject to change.

See Page 14 for complete model number schema.

¹Connections 4" IPS and above 150# ANSI FLG

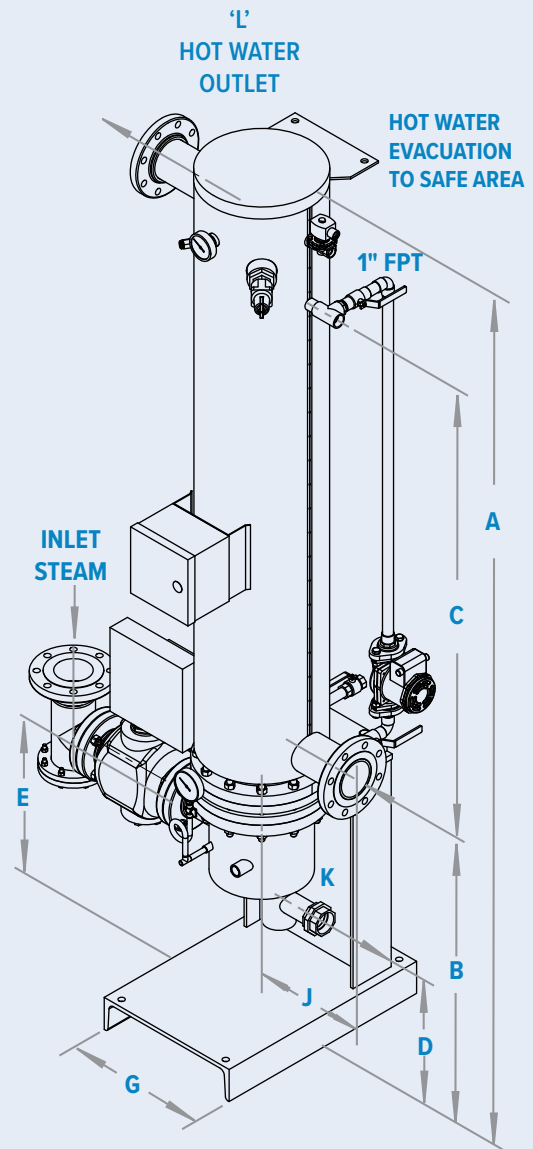

Dimensions

Double-Wall / Steam-to-Water

Horizontal

HORIZONTAL				
MODEL	A	B	C	SHIPPING WEIGHT (LBS.)
SI-H-5-DW-Sxx	85	14 1/4	55	435
SI-H-6-DW-Sxx	86 1/4	15	54 1/2	535
SI-H-8-DW-Sxx	83 3/4	16 1/2	55 1/4	635
SI-H-10-DW-Sxx	88	18 1/4	56 1/2	950
SI-H-12-DW-Sxx	95 3/4	24 1/2	55	1,200
SI-H-14-DW-Sxx	109	28 1/2	63	1,750
SI-H-16-DW-Sxx	116 1/2	32 1/2	66	2,250

All dimensions in inches. Dimensions are subject to change.
See Page 14 for complete model number schema.

¹ Connections 4" IPS and above 150# ANSI FLG

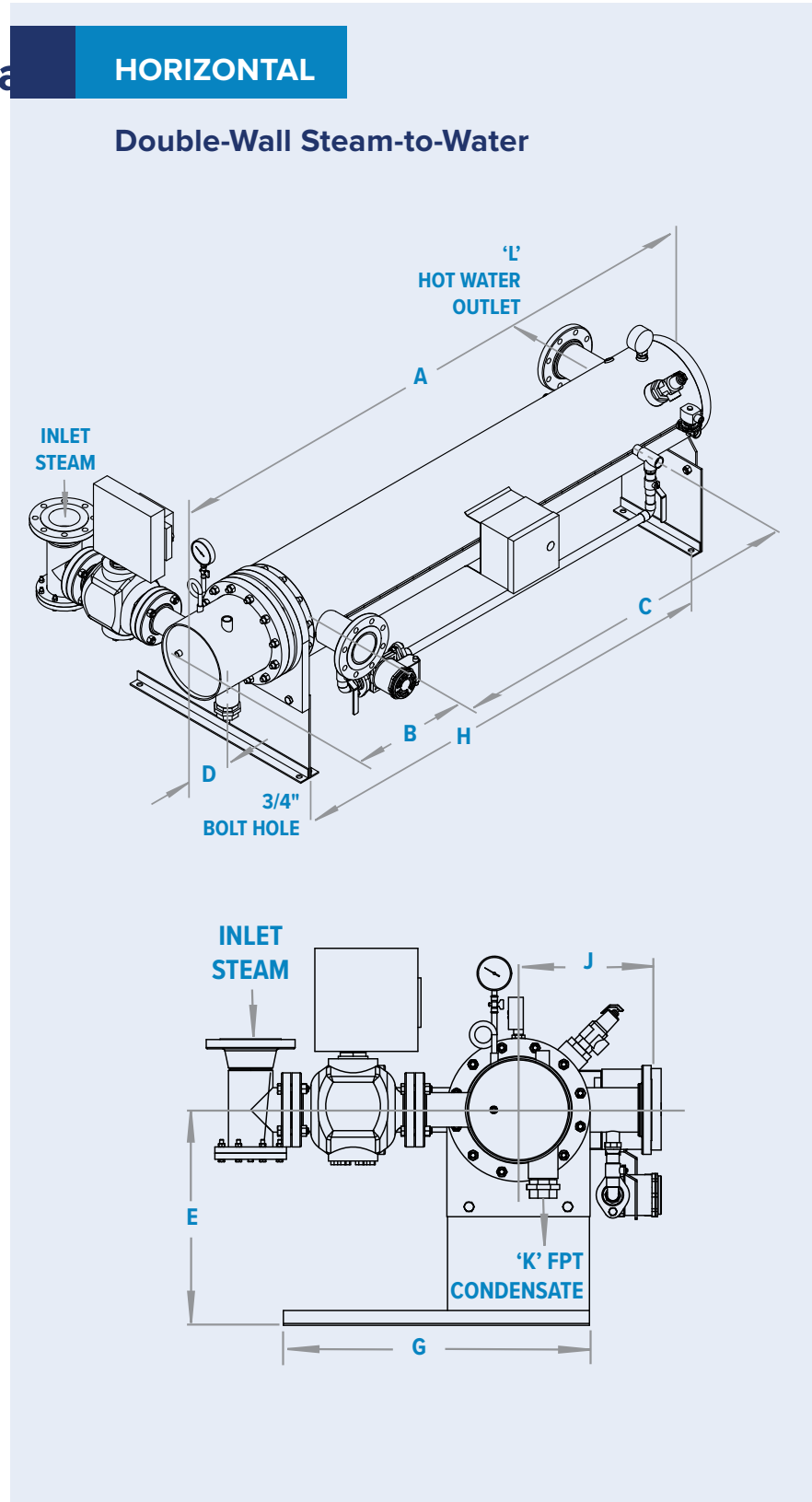

Dimensions

Single-Wall Water-to-Water

VERTICAL				
MODEL	A	B	C	SHIPPING WEIGHT (LBS.)
SI-V-4-SW-Wxx	83	40	30	300
SI-V-5-SW-Wxx	69 3/4	33 3/4	23	350
SI-V-6-SW-Wxx	86	42	31 3/4	400
SI-V-8-SW-Wxx	75 1/2	36 1/2	24 3/4	500
SI-V-8L-SW-Wxx	114 1/2	56 1/2	43 3/4	550
SI-V-10-SW-Wxx	79 1/2	38 3/4	25	850
SI-V-12-SW-Wxx	83 1/2	41 3/4	24 1/2	1,075
SI-V-12L-SW-Wxx	107 1/2	53 3/4	36 1/2	1,200
SI-V-14-SW-Wxx	90	48 3/4	30 1/2	1,550
SI-V-14L-SW-Wxx	128 1/2	63 3/4	45 1/2	1,850
SI-V-16-SW-Wxx	122	60 3/4	40 1/2	2,125
SI-V-16L-SW-Wxx	150	78 3/4	54 1/2	2,350

All dimensions in inches. Dimensions are subject to change.
See page 14 for complete model number schema.

¹Connections 4" IPS and above 150# ANSI FLG

VERTICAL

Single-Wall Water-to-Water

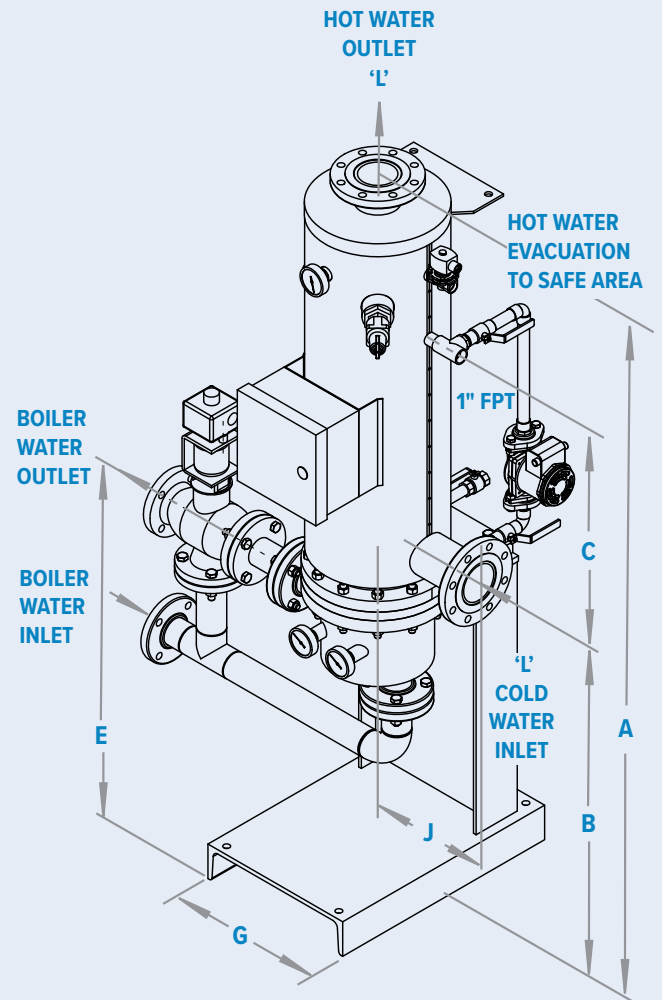

Single-Wall Water-to-Water

HORIZONTAL				
MODEL	A	B	C	SHIPPING WEIGHT (LBS.)
SI-H-4-SW-Wxx	56 1/4	13 1/4		275
SI-H-5-SW-Wxx	49 1/4	13 1/4		300
SI-H-6-SW-Wxx	57 3/4	13 3/4		350
SI-H-8-SW-Wxx	54 1/4	15 1/4		450
SI-H-8L-SW-Wxx	60 1/4	15 1/4		500
SI-H-10-SW-Wxx	55 3/4	15 1/4		800
SI-H-10L-SW-Wxx	61 3/4	15 1/4		850
SI-H-12-SW-Wxx	58 1/2	17		1,025
SI-H-12L-SW-Wxx	70 1/2	17		1,150
SI-H-14-SW-Wxx	70 3/4	21		1,500
SI-H-14L-SW-Wxx	85 3/4	21		1,800
SI-H-16-SW-Wxx	84 1/4	23		2,075
SI-H-16L-SW-Wxx	98 1/4	23		2,300

All dimensions in inches. Dimensions are subject to change.

See page 14 for complete model number schema.

¹Connections 4" IPS and above 150# ANSI FLG

HORIZONTAL

Single-Wall Water-to-Water

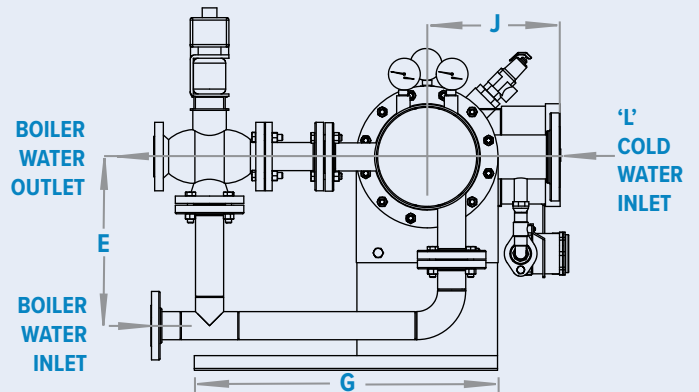
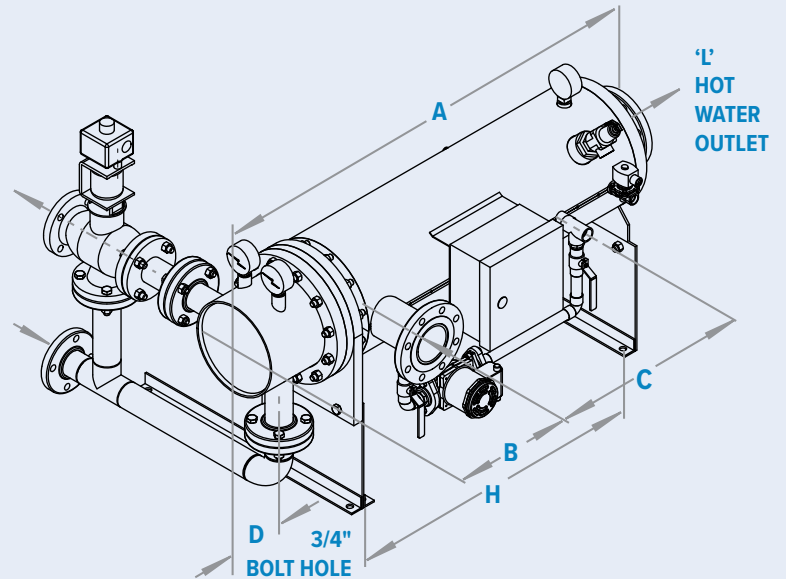

Dimensions

Double-Wall Water-to-Water

VERTICAL				
MODEL	A	B	C	SHIPPING WEIGHT (LBS.)
SI-V-5-DW-Wxx	98 1/2	271/2		425
SI-V-6-DW-Wxx	102	303/4		500
SI-V-8-DW-Wxx	983/4	311/2		700
SI-V-10-DW-Wxx	1051/2	353/4		1,100
SI-V-12-DW-Wxx	1101/2	391/4		1,425
SI-V-14-DW-Wxx	122	413/4		1,975
SI-V-16-DW-Wxx	1281/2	44		2,475

All dimensions in inches. Dimensions are subject to change.
 See page 14 for complete model number schema.
 † Connections 4" IPS and above 150# ANSI FLG

VERTICAL

Double-Wall Water-to-Water

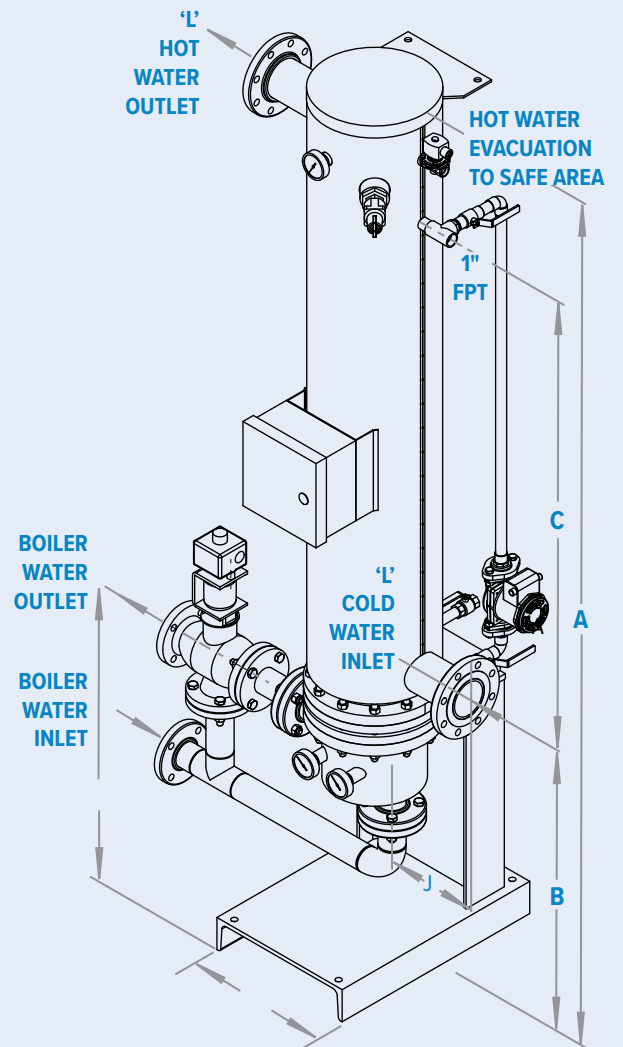

Double-Wall Water-to-Water

HORIZONTAL

Double-Wall Water-to-Water

HORIZONTAL

MODEL	A	B	C	SHIPPING WEIGHT (LBS.)
SI-H-5-DW-Wxx	85	14 1/4		375
SI-H-6-DW-Wxx	86 1/4	15		450
SI-H-8-DW-Wxx	83 3/4	16 1/2		650
SI-H-10-DW-Wxx	86 1/4	16 1/2		1,050
SI-H-12-DW-Wxx	89 3/4	18 1/2		1,375
SI-H-14-DW-Wxx	103 3/4	23 1/2		1,925
SI-H-16-DW-Wxx	109 1/2	25 1/2		2,425

All dimensions in inches. Dimensions are subject to change.
See page 14 for complete model number schema.

¹ Connections 4" IPS and above 150# ANSI FLG

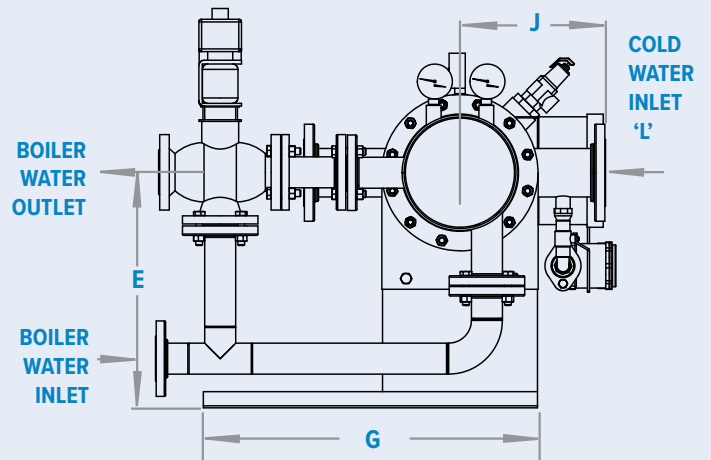
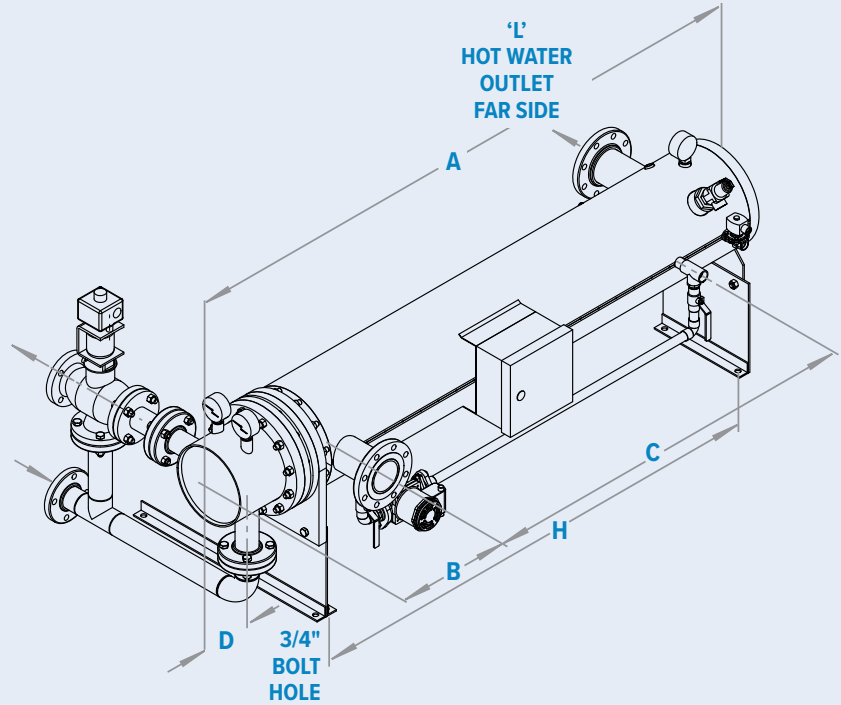



Ace Heaters
130 Klug Circle
Corona, CA 92880
United States

(951) 738-2230
info@aceheaters.com
www.aceheaters.com

© 2024 ACE HEATERS
PRINTED IN THE U.S.A.